

# SIGARMS™ SIGHT ADJUSTMENT TOOL

## Operating Instructions

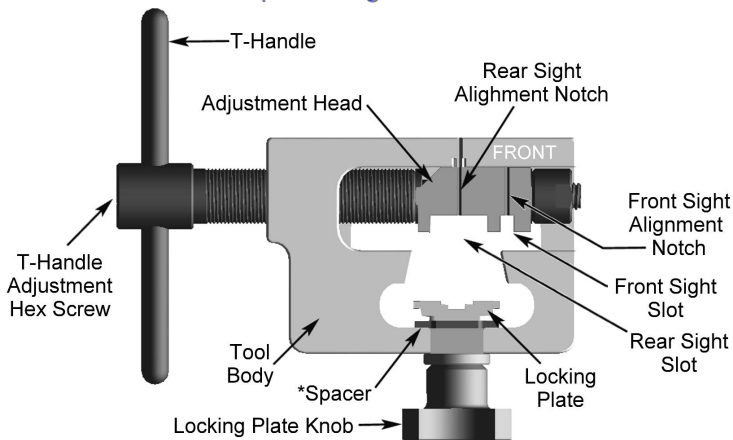

The SIGARMS™ Sight Adjustment Tool is used to adjust, remove and install front and rear sights on SIG Sauer™ Pistols. There are two variants - one for Classic Pistols (P220, P225, P226, P228, P229, P239, P245) and one for *sigpro*™ Pistols (SP2340, SP2009). This card includes separate instructions for front & rear sights, as well as general information to assist you in sighting your pistol.

### **UNLOAD THE PISTOL BEFORE STARTING!**

#### General Information

1. You can adjust the position of the T-Handle by loosening the T-Handle Adjustment Hex Screw (use a 1/8" hex key) - do not overtighten.
2. Sights may be removed from either side of the slide. Sights should ALWAYS be installed from the left side of the slide, as viewed by the shooter when firing.
3. When installing, the sight base must be aligned and seated in the dovetail of the slide before making adjustments with the Sight Adjustment Tool. Tapping the opposite side of the sight base with a plastic hammer or end of a plastic screw driver will help seat the sight in the dovetail.
4. A drop of gun oil in the dovetail slot prior to starting will ease installation.
5. Not all after-market sights may be manufactured to the correct dovetail dimensions - to ensure the right fit use only genuine SIG Sauer™ sights - available in contrast, three-dot, and SIGLITE™ night sights.

**SIGARMS**®

# SIGARMS™ SIGHT ADJUSTMENT TOOL

## Operating Instructions / Front Sight

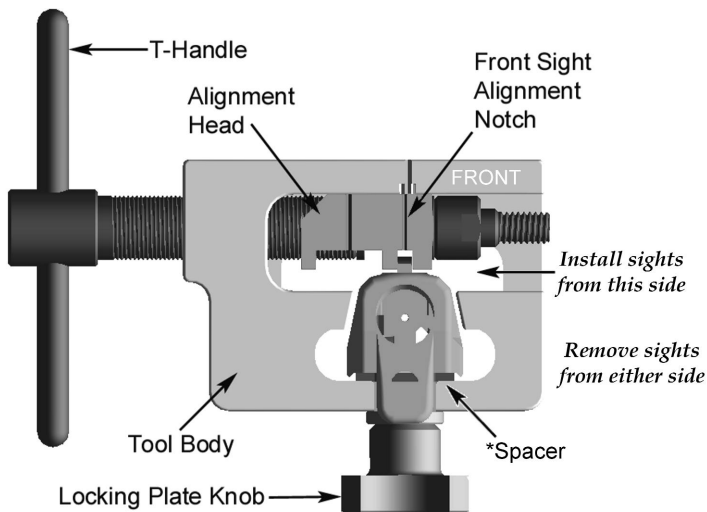

**\* Remove Spacer for P239  
in .40 S&W / .357 SIG**

## Front Sight Adjustment, Removal and Installation

1. Unload & field strip the pistol.
2. Install the slide on the Locking Plate from the front of the tool body. Ensure the Alignment Head is centered allowing the rear sight to pass through its slot for correct slide positioning within the tool.
3. Center the front sight blade in the narrow slot of the Alignment Head.
4. Tighten the Locking Plate Knob hand tight
5. Turn the T-handle to move the Alignment Head & sight in the desired direction.

*Note: See the front page of these instructions for information that will assist you in correctly installing your new sights.*

**SIGARMS®**

*Note: Diagram may vary from actual tool.*

# SIGARMS™ SIGHT ADJUSTMENT TOOL

## Operating Instructions / Rear Sight

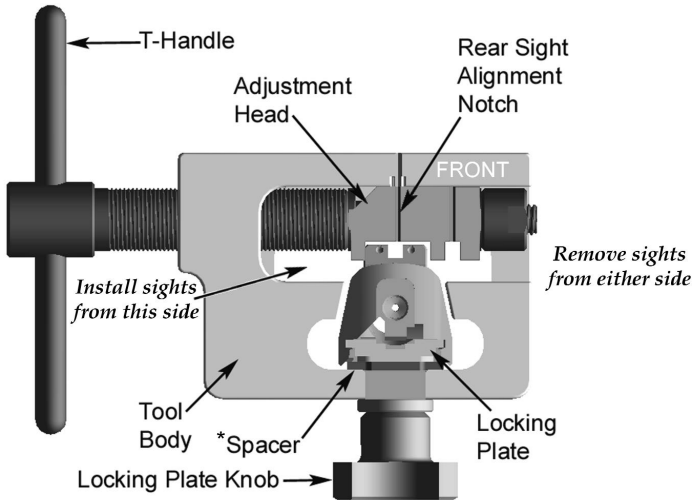

**\* Remove Spacer for P239  
in .40 S&W / .357 SIG**

## Rear Sight Adjustment, Removal and Installation

1. Unload & field strip the pistol.
2. Install the slide on the Locking Plate from the rear of the tool body.
3. Center the rear sight blade in the wide slot of the Alignment Head.
4. Tighten the Locking Plate Knob hand tight
5. Turn the T-handle to move the Alignment Head & sight in the desired direction.

*Note: See the front page of these instructions for information that will assist you in correctly installing your new sights.*

**SIGARMS®**

*Note: Diagram may vary from actual tool.*

# SIGARMS™ SIGHT ADJUSTMENT TOOL

## Sight Adjustment - General Information

**General Note** - No sight corrections should be made until the shooter has become familiar with the firing characteristics of the pistol.

When zeroing, the target should be at 25 yards and the pistol should be fired from a rested position (use single-action mode for best results - not applicable if pistol is Double-Action Only). Sighting should be "**point of aim, point of impact.**"

**1. Windage (left/right)** - A change in windage is accomplished by moving the rear sight either to the left or right in its dovetail. When doing this, follow the rear sight rule: "**To move impact left, move rear sight left; to move impact right, move rear sight right**". Moving the rear sight 0.020 inches in the dovetail alters the point of impact by approximately 3 inches at 25 yards.

**2. Elevation (up/down)** - For both the front and rear sights, 30 different height combinations are available. The sights are numbered according to their height. A change in elevation is accomplished by changing either the rear or front sight. It is recommended that the rear sight be changed first. The sight number is shown on each sight.

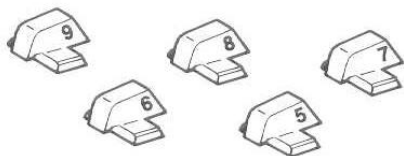

*1" between number changes at 25 yards*

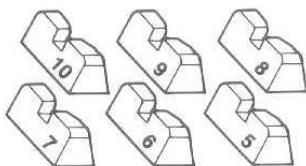

*2" between number changes at 25 yards*

When changing the sights, remember this rule: "**NUMBERS UP, IMPACT UP; NUMBERS DOWN, IMPACT DOWN**". This is true whether it concerns the front or rear sights. Replacement sights in the various height combinations are available from SIGARMS.

# SIGARMS®