

# **SIGSAUER®**



## ***SIG MCX-SPEAR LT®***

***OPERATOR'S MANUAL: HANDLING & SAFETY INSTRUCTIONS***

READ THE INSTRUCTIONS AND WARNINGS IN THIS MANUAL CAREFULLY BEFORE USING THIS FIREARM. DO NOT DISCARD THIS MANUAL.

THIS MANUAL SHOULD ALWAYS ACCOMPANY THIS FIREARM AND BE TRANSFERRED WITH IT UPON CHANGE IN OWNERSHIP, OR WHEN THE FIREARM IS PRESENTED TO ANOTHER PERSON.





# WARNINGS

## 1.0 SAFETY WARNINGS

### READ THIS ENTIRE MANUAL THOROUGHLY AND CAREFULLY PRIOR TO USING THIS FIREARM.

The warnings in this operators manual are extremely important. By understanding the dangers inherent in the use of any firearm, and by taking the precautions described in this manual, you can experience a high level of safety in the use of your firearm. Failure to heed any of these warnings may result in serious injury or death to you or others, as well as severe damage to the firearm or other property.

**WARNINGS** in this manual identify a clear danger to the person performing that procedure. Warnings are identified by a red banner with the word **WARNING** in white, bold, uppercase letters and a **WARNING** icon. Failure to comply with a **WARNING** can result in serious injury or death to you or a bystander.



## WARNING

**CAUTIONS** in this manual identify a risk of damage to the firearm being maintained. **CAUTIONS** are identified by a black banner with the word **CAUTION** in white, bold, uppercase letters.

## CAUTION



# WARNINGS

**SIG SAUER**

As a valued SIG SAUER customer, we encourage you to visit [sigsauer.com](http://sigsauer.com). There you will find links to product information and updates, merchandise promotions, and educational videos that will be of interest to you as an owner of SIG SAUER products.

SIG SAUER firearms are designed to function reliably with proper care and knowledgeable use. You must understand the safe operation and use of your SIG SAUER firearm. Read and follow these instructions carefully. Do not use the firearm unless you fully understand these instructions and the safe operation of your firearm. Failure to heed any of these instructions may result in serious injury or death to you or others, as well as severe damage to the firearm or other property.

Your firearm comes equipped with effective, well-designed safety features. However, never rely completely on any safety mechanism. Safety mechanisms are designed to augment, not replace safe handling practices. Careless and improper handling of any firearm can result in an unintentional discharge.

Only your safe firearm handling habits will ensure the safe use of your firearm. Like all mechanical devices, the safety mechanisms are subject to breakage or malfunction and can be negatively affected by wear, abuse, dirt, corrosion, incorrect assembly, improper adjustment or repair, or lack of maintenance. Moreover, there is no such thing as a safety mechanism that is “childproof” or that can completely prevent accidental discharge from improper usage, carelessness, “horseplay”, or abusive handling.

The best safety is proper and applied training in safe firearm handling. Always handle your firearm as though you expect the safeties not to work.



# WARNINGS

## 1.0 SAFETY WARNINGS – CONTINUED

Do not load a cartridge into the chamber until you are ready to use the firearm. Keep the firearm on SAFE until you are actually ready to use the firearm. Always move the selector fully to its engaged position and visually check it. The selector is not on SAFE unless it is completely on SAFE.

### ABUSIVE HANDLING

SIG SAUER firearms incorporate effective mechanical safeties. However, like any mechanical device, exposure to abusive conditions may have a negative effect on these safety mechanisms and cause them to fail to work as designed. Do not subject your SIG SAUER firearm to any type of abusive handling. This includes the firearm being dropped, impact to the firearm, or the firearm being struck by another object. Make sure you always maintain control of your firearm at all times. If your firearm does suffer an abusive event such as previously described, do not attempt to use the firearm. Keep the firearm pointed in a safe direction, unload and clear the firearm of all ammunition immediately, and have it inspected by a certified SIG SAUER armorer or gunsmith prior to using the firearm.

A safe direction is defined as an area in which, if the firearm were to discharge, no property damage would occur and no personal injury would result.

As previously noted, if your SIG SAUER firearm does suffer an abusive event, unload it immediately and have it inspected by a certified SIG SAUER Armorer or gunsmith prior to using the firearm.

Intentional or repetitive abusive handling of any SIG SAUER firearm will void the manufacturer's warranty and could render the firearm unsafe.



# WARNINGS

**SIG SAUER**

## **REPLACEMENT PARTS**

Do not attempt to disassemble your SIG SAUER firearm beyond the point explained in this manual. Disassembly beyond the instructions in this manual is restricted to a certified SIG SAUER armorer or professional gunsmith. Failure to comply with these restrictions will void your warranty.

Warnings and instructions about the use of some SIG SAUER replacement parts, assemblies, and accessories may be described in literature accompanying the specific products. Read and carefully follow those instructions. Such warnings and instructions are provided to assure the safe functioning of the firearm. Failure to heed them may result in improper functioning, damage to the firearm, and serious injury or death to you or others.

## **ALTERATIONS**

This SIG SAUER firearm was designed to function properly in its original condition. Unauthorized alterations can make it unsafe. Do not alter any part or add or substitute any parts or accessories not manufactured by SIG SAUER for this pistol. The addition of any parts or accessories beyond the user level of maintenance described in this manual is not authorized.



# WARNINGS

## 1.0 SAFETY WARNINGS – CONTINUED

### ACCESSORIES

It is your responsibility to ensure that all accessories, such as slings and firearm-mounted lights, are compatible with this firearm and that the accessories do not interfere with the safe operation and handling of the firearm.

### TRANSPORTING

When transporting your firearm, be sure the firearm is unloaded and cleared of all ammunition. It is your responsibility to familiarize yourself with the laws of any state you will be traveling through with your firearm.

### STORAGE

The only safe way to store your firearm is unloaded, cleared of all ammunition, and secure. Safe and secure storage is one of your most important responsibilities. Store your unloaded firearm separate from your ammunition and in places inaccessible to children or unauthorized persons.

### CHAMBER SAFETY FLAG

Every SIG SAUER firearm is shipped with a chamber safety flag. The chamber safety flag prevents the chambering of a round when installed and provides a readily visible indication that the firearm's chamber is empty. The chamber safety flag is to be installed in the firearm's chamber at all times when the firearm is not in use. Many public ranges require chamber safety flags be installed when the firing line is cold.



# WARNINGS

**SIG SAUER**

## LIABILITY

PISTOLS are classified as FIREARMS and are sold by SIG SAUER with the specific understanding that we shall not be responsible in any manner whatsoever for malfunctioning of the firearm, physical injury, or property damage resulting in whole or in part from:

- Criminal or negligent discharge
- Improper, careless, or abusive handling
- Unauthorized modifications or parts replacement
- Defective, improper, hand-loaded, or reloaded ammunition
- Corrosion
- Neglect
- Other influences beyond our direct and immediate control

This limitation applies regardless of whether liability is asserted on the basis of contract, negligence, or strict liability (including any failure to warn). Under no circumstance shall SIG SAUER, Inc. be liable for incidental or consequential damages such as loss of use of property, commercial loss, and loss of earnings or profits.



# WARNINGS

## BASIC RULES OF SAFE FIREARMS HANDLING

1. ALWAYS treat every firearm as if it were loaded.
2. ALWAYS be sure the barrel is clear of any obstruction.
3. ALWAYS be sure of your backstop, what lies beyond, and the safety of bystanders before you shoot.
4. ALWAYS use clean, dry, original factory-made ammunition of the proper type and caliber for your firearm.
5. ALWAYS wear ear protection and safety glasses when shooting.
6. ALWAYS carry your firearm so that you can control the direction of the muzzle if you fall or stumble.
7. NEVER shoot at a flat surface or water.
8. DO NOT leave a loaded firearm unattended. Firearms and ammunition should be stored separately, locked if possible, beyond the reach of children, careless adults, or unauthorized users.
9. NEVER allow your firearm to be used by anyone who has not read and understood this operators manual.
10. DO NOT point any firearm, loaded or unloaded, at any undesired or unsafe target.
11. NEVER discharge your firearm near an animal unless the animal is trained to accept the noise. An animal's startled reaction could injure it or cause an accident.
12. NEVER drink alcoholic beverages or use drugs before or during shooting, as your vision and judgment could be seriously impaired, making your firearm handling unsafe.





# WARNINGS

**SIG SAUER**

## 1.1 EYE AND EAR PROTECTION



Always wear safety glasses that meet the requirements of American National Standards Institute (ANSI) z87.1 and ear plugs and “ earmuff ”-type protectors whenever you are shooting. Always make certain that persons close to you are similarly protected. Unprotected eyes may be injured by powder, gas, carbon residue, lubricant, metallic particles, or similar debris that may emanate occasionally from any firearm in normal use. Without ear protection, repeated exposure to shooting noise may lead to cumulative, permanent hearing loss.

## 1.2 AMMUNITION

Use only high-quality, original, factory-manufactured ammunition. Do not use cartridges that are dirty, wet, corroded, bent, or damaged. Do not oil cartridges. Do not spray aerosol-type lubricants, preservative, or cleaners directly onto cartridges or where excess spray may flow into contact with cartridges. Lubricant or other foreign matter on cartridges can cause potentially dangerous ammunition malfunctions. Use only ammunition of the caliber for which your firearm is chambered. The proper caliber is permanently engraved on your firearm; never attempt to use ammunition of any other caliber.

The use of reloaded, “re-manufactured” hand-loaded, or other nonstandard ammunition voids all warranties. Reloading is a science and improperly loaded ammunition can be extremely dangerous.



# WARNINGS

## 1.2 AMMUNITION – CONTINUED

Severe damage to the firearm and serious injury or death to the shooter or to others may result. Always use ammunition that complies with the industry performance standards established by the Sporting Arms and Ammunition Manufacturers' Institute, Inc. (SAAMI) or ammunition manufactured to U.S. military specifications.

SIG SAUER, Inc. specifically disclaims responsibility for any damage or injury whatsoever occurring in connection with, or as a result of, the use in any SIG SAUER firearm of faulty, nonstandard, "re-manufactured" hand-loaded (reloaded) ammunition, or cartridges other than those for which the firearm was originally chambered.

Firearms may be severely damaged and serious injury or death to the shooter or to others may result from any condition causing excessive pressure inside the chamber or barrel during firing. Excessive pressure can be caused by obstructions in the barrel, propellant powder overloads, the use of incorrect cartridges, or defectively assembled cartridges. In addition, the use of a dirty, corroded, or damaged cartridge can lead to a burst cartridge case and consequent damage to the firearm and personal injury from the sudden escape of high-pressure propellant gas within the firearm's mechanism.

### **OBSTRUCTED BORE**

Immediately stop shooting, keep the pistol pointed in a safe direction whenever:

- You have difficulty in, or feel unusual resistance in, chambering a cartridge;
- A cartridge misfires (does not go off);
- The mechanism fails to extract a fired cartridge case;
- Unburned grains of propellant powder are discovered spilled in the mechanism;
- A shot sounds weak or abnormal. It is possible that a bullet is lodged part way down the barrel.



# WARNINGS

**SIG SAUER**

Firing a subsequent bullet into the obstructed barrel can damage the firearm and cause serious injury to the shooter or to bystanders.

Bullets can become lodged in the barrel when:

- The cartridge has been improperly loaded without propellant powder, or if the powder fails to ignite (ignition of the cartridge primer alone will push the bullet out of the cartridge case, but usually does not generate sufficient energy to expel the bullet completely from the barrel);
- The bullet is not properly seated in the cartridge case. When such a cartridge is extracted from the chamber without being fired, the bullet may be left behind in the bore at the point where the rifling begins. Subsequent chambering of another cartridge may push the first bullet further into the bore.

If there is any reason to suspect that a bullet is obstructing the barrel, immediately unload and clear the firearm. Field strip the pistol and look through the bore of the barrel. It is not sufficient to merely look in the chamber. A bullet may be lodged some distance down the barrel where it cannot easily be seen.

If a bullet is in the bore, do not attempt to shoot it out by using another cartridge or by blowing it out with a blank or a cartridge from which the bullet has been removed. Such techniques can generate excessive pressure, damage the firearm, and cause serious personal injury or death.

If the bullet can be removed by tapping it with a cleaning rod, clean any unburned powder grains from the bore, chamber, and mechanism, before resuming shooting. If the bullet cannot be dislodged by tapping it with a cleaning rod, take the firearm to a gunsmith or certified SIG SAUER Armorer.



# WARNINGS

## 1.2 AMMUNITION – CONTINUED

Dirt, corrosion, or other foreign matter on a cartridge can impede chambering and may cause the cartridge case to burst upon firing. A damaged or deformed cartridge may also impede chambering or cause the cartridge case to burst upon firing.

Do not lubricate cartridges, and be sure to wipe the chamber clean of any oil or preservative before shooting. Oil interferes with the friction between cartridge case and chamber wall that is necessary for safe functioning, and subjects the firearm to stress similar to that imposed by excessive pressure.

Use lubricants sparingly on the moving parts of your firearm. Avoid excessive spraying of any aerosol gun care product, especially where it might get on ammunition. All lubricants and aerosol spray lubricants in particular can penetrate cartridge primers and cause misfires. Some highly penetrative lubricants can also migrate inside cartridge cases and cause deterioration of the propellant powder; on firing, the powder might not ignite. If only the primer ignites, there is danger that the bullet may become lodged in the barrel.

Death, serious injury, and damage to the firearm can result from the use of wrong ammunition, bore obstructions, powder overloads, or incorrect cartridge components. Always wear shooting glasses and hearing protectors.



# WARNINGS

**SIG SAUER**



**WARNING: CANCER AND REPRODUCTIVE HARM—[www.P65warnings.ca.gov](http://www.P65warnings.ca.gov)**



DISCHARGING FIREARMS IN POORLY VENTILATED AREAS, CLEANING FIREARMS, OR HANDLING AMMUNITION MAY RESULT IN EXPOSURE TO LEAD AND OTHER SUBSTANCES KNOWN TO THE STATE OF CALIFORNIA TO CAUSE BIRTH DEFECTS, REPRODUCTIVE HARM, AND OTHER SERIOUS PHYSICAL INJURY. MAINTAIN ADEQUATE VENTILATION AT ALL TIMES. WASH HANDS THOROUGHLY AFTER EXPOSURE. SHOOTING OR CLEANING FIREARMS MAY EXPOSE YOU TO LEAD



# WARNINGS

## 1.3 STATE-BY-STATE WARNINGS

Certain states require, by law, that their own specified warning notices, in larger than-normal type be conspicuously included by the manufacturer, distributor, or retail dealer with firearms sold in that state. SIG SAUER sells its products in compliance with applicable laws and regulations. Because our products may be sold in these states, we include the following:



### **CALIFORNIA: WARNING**

Firearms must be handled responsibly and securely stored to prevent access by children and other unauthorized users. California has strict laws pertaining to firearms, and you may be fined or imprisoned if you fail to comply with them. Visit the Web site of the California Attorney General at <https://oag.ca.gov/firearms> for information on firearm laws applicable to you and how you can comply. Prevent child access by always keeping guns locked away and unloaded when not in use. If you keep a loaded firearm where a child obtains and improperly uses it, you may be fined or sent to prison."

If you or someone you know is contemplating suicide, please call the National Suicide Prevention Lifeline at 1-800-273 TALK (8255).



### **ADVERTENCIA**

Las armas de fuego deben manipularse de manera responsable y segura para evitar el acceso de niños y otros usuarios no autorizados. California tiene leyes estrictas relacionadas con armas de fuego, y usted puede ser multado o encarcelado si no las cumple. Visite el sitio web del fiscal general de California en <https://oag.ca.gov/firearms> para obtener información sobre las leyes de armas de fuego que son aplicables y cómo puede cumplirlas. Evite el acceso de niños manteniendo siempre las armas bloqueadas y descargadas cuando no estén en uso. Si mantiene un arma de fuego cargada donde un niño la puede obtener y la usa indebidamente, se le puede multar o enviar a prisión.

Si usted o alguien que conoce está contemplando el suicidio, llame a la Línea Nacional de Prevención del Suicidio al 1-800-273 TALK (8255).



# WARNINGS

**SIG SAUER**

## **CONNECTICUT:**

"UNLAWFUL STORAGE OF A LOADED FIREARM MAY RESULT IN IMPRISONMENT OR FINE."

## **FLORIDA:**

"IT IS UNLAWFUL, AND PUNISHABLE BY IMPRISONMENT AND FINE, FOR ANY ADULT TO STORE OR LEAVE A FIREARM IN ANY PLACE WITHIN THE REACH OR EASY ACCESS OF A MINOR UNDER 18 YEARS OF AGE OR TO KNOWINGLY SELL OR OTHERWISE TRANSFER OWNERSHIP OR POSSESSION OF A FIREARM TO A MINOR OR A PERSON OF UNSOUND MIND."

## **MAINE:**

"ENDANGERING THE WELFARE OF A CHILD IS A CRIME. IF YOU LEAVE A FIREARM AND AMMUNITION WITHIN EASY ACCESS OF A CHILD, YOU MAY BE SUBJECT TO FINE, IMPRISONMENT OR BOTH. KEEP FIREARMS AND AMMUNITION SEPARATE. KEEP FIREARMS AND AMMUNITION LOCKED UP. USE TRIGGER LOCKS."

## **MARYLAND:**

"WARNING: CHILDREN CAN OPERATE FIREARMS WHICH MAY CAUSE DEATH OR SERIOUS INJURY. IT IS A CRIME TO STORE OR LEAVE A LOADED FIREARM IN ANY LOCATION WHERE AN INDIVIDUAL KNEW OR SHOULD HAVE KNOWN THAT AN UNSUPERVISED MINOR WOULD GAIN ACCESS TO THE FIREARM. STORE YOUR FIREARM RESPONSIBLY!"



# WARNINGS

## MASSACHUSETTS:

“WARNING FROM THE MASSACHUSETTS ATTORNEY GENERAL: This handgun is not equipped with a device that fully blocks use by unauthorized users. More than 200,000 firearms like this one are stolen from their owners every year in the United States. In addition, there are more than a thousand suicides each year by younger children and teenagers who get access to firearms. Hundreds more die from accidental discharge. It is likely that many more children sustain serious wounds, or inflict such wounds accidentally on others. In order to limit the chance of such misuse, it is imperative that you keep this weapon locked in a secure place and take other steps necessary to limit the possibility of theft or accident. Failure to take reasonable preventative steps may result in innocent lives being lost, and in some circumstances may result in your liability for these deaths.”





# WARNINGS

**SIG SAUER**

## **MASSACHUSETTS: - Continued**

“IT IS UNLAWFUL TO STORE OR KEEP A FIREARM, PISTOL, SHOTGUN OR MACHINE GUN IN ANY PLACE UNLESS THAT WEAPON IS EQUIPPED WITH A TAMPER RESISTANT SAFETY DEVICE OR IS STORED OR KEPT IN A SECURELY LOCKED CONTAINER.”

## **NEW JERSEY:**

“IT IS A CRIMINAL OFFENSE TO LEAVE A LOADED FIREARM WITHIN EASY ACCESS OF A MINOR.”

## **NEW YORK CITY, NY:**

“THE USE OF A LOCKING DEVICE OR SAFETY LOCK IS ONLY ONE ASPECT OF RESPONSIBLE FIREARMS STORAGE. FOR INCREASED SAFETY, FIREARMS SHOULD BE STORED UNLOADED AND LOCKED IN A LOCATION THAT IS BOTH SEPARATE FROM THEIR AMMUNITION AND INACCESSIBLE TO CHILDREN AND OTHER UNAUTHORIZED PERSONS.”



# WARNINGS

## **NORTH CAROLINA:**

Any person who resides in the same premises as a minor, owns or possesses a firearm, and stores or leaves the firearm (i) in a condition that the firearm can be discharged and (ii) in a manner that the person knew or should have known that an unsupervised minor would be able to gain access to the firearm, is guilty of a Class 1 misdemeanor if a minor gains access to the firearm without the lawful permission of the minor's parents or a person having charge of the minor and the minor:

- (1) Possesses it in violation of G.S. 14-269.2(b)
- (2) Exhibits it in a public place in a careless, angry, or threatening manner;
- (3) Causes personal injury or death with it not in self defense; or
- (4) Uses it in the commission of a crime.

## **TEXAS:**

"IT IS UNLAWFUL TO STORE, TRANSPORT, OR ABANDON AN UNSECURED FIREARM IN A PLACE WHERE CHILDREN ARE LIKELY TO BE AND CAN OBTAIN ACCESS TO THE FIREARM."

## **WISCONSIN:**

"IF YOU LEAVE A LOADED FIREARM WITHIN THE REACH OR EASY ACCESS OF A CHILD YOU MAY BE FINED OR IMPRISONED OR BOTH IF THE CHILD IMPROPERLY DISCHARGES, POSSESSES, OR EXHIBITS THE FIREARM."

Please check with your licensed retailer, state police, or local police for additional warnings, which may be required by local law or regulation. Such regulations change constantly, and local authorities are in the best position to advise you on such legal matters.



# WARNINGS

**SIG SAUER**

## 1.4 LOCKING DEVICES



All firearms are originally shipped with a key-operated locking device, except for Custom Works firearms that are shipped with a lockable case.

Although it can help provide secure storage for your unloaded firearm, any locking device can fail.

All firearms are designed to fire if they are loaded and the trigger is pressed.

Therefore, never install the locking device inside the trigger guard or in any way that makes it possible to press the trigger!

Do not leave the keys in the lock.

The ultimate responsibility for secure storage of any firearm must depend upon its owner and his or her individual circumstances.

Firearms should be stored unloaded, in a secure location, separate from their ammunition.

To maximize effectiveness and reduce the chances of malfunction or damage to a firearm, ALWAYS refer to the locking device's manufacturer directions for installation and removal of the device.



# WARNINGS

## 1.5 SAFETY INFORMATION

This operator's manual is designed to assist you in learning how to use and care for your SIG SAUER® firearm properly.

Only when you are certain that you fully understand this manual and can properly carry out its instructions, should you practice loading and firing your firearm with live ammunition. Having a firearm in your possession is a full-time job; you cannot guess and you cannot forget. You must know how to use your firearm safely.

If you have any doubts about your ability to handle or use this firearm safely, you should seek supervised instruction.

The SIG SAUER Academy provides all levels of firearms safety and skill training, from beginner to expert.

For more information contact:

**SIG SAUER**<sup>®</sup>  
**ACADEMY**

sigsaueracademy.com • (603) 610-3400  
Epping, New Hampshire

**SAFETY MUST BE THE FIRST AND CONSTANT CONSIDERATION OF EVERY PERSON WHO HANDLES FIREARMS AND AMMUNITION.**

For more information about safety, responsible firearms ownership, and shooting sports, contact:  
National Rifle Association (NRA) of America  
11250 Waples Mill Road, Fairfax, VA 22030-7400 • 1-800-672-3888  
nra.com

**THIS PAGE INTENTIONALLY LEFT BLANK**



## Contents

1.0 Safety Warnings . . . . .	2
1.1 Eye And Ear Protection. . . . .	9
1.2 Ammunition. . . . .	9
1.3 State-By-State Warnings . . . . .	14
1.4 Locking Devices . . . . .	19
1.5 Safety Information . . . . .	20
2.0 Mechanical Characteristics and Rifle Theory . . . . .	24
2.1 Rifle Description . . . . .	24
2.2 Specifications. . . . .	24
2.3 Controls and Features . . . . .	26
2.4 Groups and Assemblies . . . . .	28
2.5 Cycle of Function. . . . .	34
3.0 Operating the SIG MCX-SPEAR LT . . . . .	36
3.1 Preparation before using the firearm. . . . .	36
3.2 Selecting Modes of Fire . . . . .	37
3.3 Clearing the SIG MCX-SPEAR LT . . . . .	38
3.4 Loading/Reloading . . . . .	42
3.5 Firing . . . . .	44
3.6 Two-Position Gas Valve . . . . .	45
3.7 Adverse/Special Conditions . . . . .	47
3.8 Stoppages . . . . .	49
4.0 User Level Authorized Preventive Maintenance . . . . .	50
4.1 Field Strip the SIG MCX-SPEAR LT . . . . .	50
4.2 Handguard Removal . . . . .	62
4.3 Handguard Installation . . . . .	64
4.4 Gas Valve and Piston Removal . . . . .	66
22	

4.5 Gas Valve and Piston Installation . . . . .	67
4.6 Barrel Removal . . . . .	68
4.7 Barrel Installation. . . . .	70
4.8 Folding Stock Removal. . . . .	72
4.9 Folding Stock Installation. . . . .	73
4.10 Cheek Rest Removal . . . . .	74
4.11 Cheek Rest Installation . . . . .	76
5.0 Cleaning and Lubrication. . . . .	78
5.1 Cleaning the Bore and Chamber. . . . .	79
5.2 Cleaning the Operating System . . . . .	80
5.3 Lubrication . . . . .	82
6.0 Reassembly . . . . .	86
7.0 Function Check. . . . .	94
8.0 MCX-SPEAR LT Stock . . . . .	96
8.1 Lightweight Skeletonized Folding Stock . . . . .	96
8.2 Troubleshooting . . . . .	98
8.3 Upper Receiver Assembly Parts Diagram . . . . .	100
8.4 Barrel and Handguard Assembly Parts Diagram. . . . .	102
8.5 Lower Receiver Assembly Parts Diagram . . . . .	104
9.0 Transportation and Storage . . . . .	106
10.0 Service and Replacement Parts Policy . . . . .	108
11.0 Shipping Firearms for Repair . . . . .	110
SIG SAUER® Limited Lifetime Firearms Warranty . . . . .	112



## **2.0 MECHANICAL CHARACTERISTICS AND RIFLE THEORY**

### **2.1 RIFLE DESCRIPTION**

The SIG MCX-SPEAR LT is a magazine fed, gas operated rifle available in 5.56x45 mm. NATO, 7.62x35 mm, (.300 AAC Blackout), and 7.62 x 39 mm calibers. The SIG MCX-SPEAR LT fires from a rotating locking closed bolt. The SIG MCX-SPEAR LT is available in semi-automatic and select fire rifle variants, as well as a pistol version. The operating system is a short stroke piston system enabling optimum function under adverse conditions.

The MCX-SPEAR LT is fitted with an aluminum handguard which provides a MIL-STD 1913 rail at the 12 o'clock position. There are multiple M-LOK™ mounting interfaces for accessories at the 3, 6 and 9 o'clock positions and has several sling attachment points. SIG offers the MCX-SPEAR LT with a lightweight folding stock and the MCX-SPEAR LT Pistol variants.

### **2.2 SPECIFICATIONS**

All MCX-SPEAR LT specifications and configurations can be found online at [sigsauer.com](https://www.sigsauer.com)





9 INCH PMCX-SPEAR LT



11.5 INCH PMCX-SPEAR LT

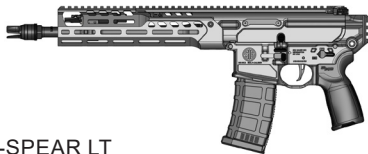

16 INCH RMCX-SPEAR LT





## 2.3 CONTROLS AND FEATURES

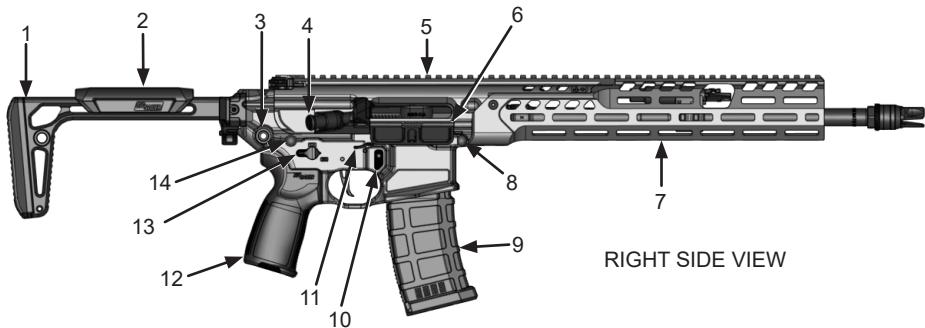

NUMBER	NOMENCLATURE	NUMBER	NOMENCLATURE
1	Buttstock	8	Pivot Pin
2	Cheek Rest	9	Magazine
3	QD Sling Cup	10	Ambidextrous Magazine Catch
4	Forward Assist	11	Ambidextrous Bolt Catch
5	Upper Receiver	12	Grip
6	Ejection Port Cover	13	Ambidextrous Selector
7	M-LOK Handguard	14	Takedown Pin

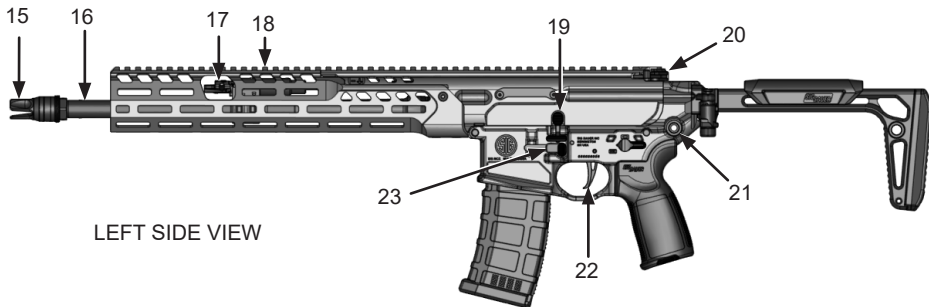

NUMBER	NOMENCLATURE	NUMBER	NOMENCLATURE
13	Ambidextrous Selector	19	Ambidextrous Bolt Catch
14	Takedown Pin	20	Ambidextrous Charging Handle
15	Flash Hider	21	QD Sling Cup
16	Barrel	22	Trigger
17	Gas Valve	23	Ambidextrous Magazine Catch
18	MIL-STD 1913 Rail		



## 2.4 GROUPS AND ASSEMBLIES

### 2.4.1 UPPER RECEIVER GROUP

The upper receiver group consists of the following:

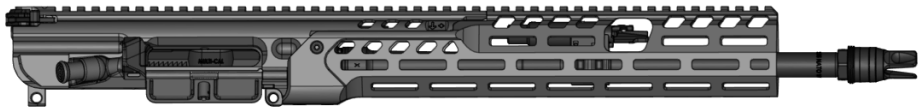

- A. Ambidextrous Charging Handle Assembly



## B. MCX-SPEAR LT Carriage Assembly

The SIG MCX-SPEAR LT operating system differs from common M16/M4 type systems. The recoil system eliminates the need for a conventional buffer and receiver extension. The result is the ability to utilize folding and collapsible stocks. The carriage assembly pictured below is removed as a single unit during field stripping and maintenance by the operator.

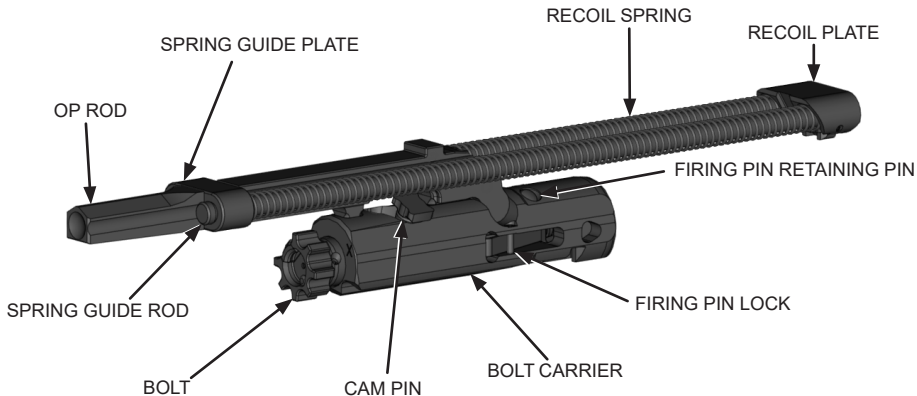



### C. Barrel Assembly

The SIG MCX-SPEAR LT barrel assembly includes the barrel extension, barrel, gas block, gas valve, gas piston, and the flash hider.

The image below depicts a 16 inch 5.56 barrel assembly. Other calibers and configurations may have parts that are different in appearance.

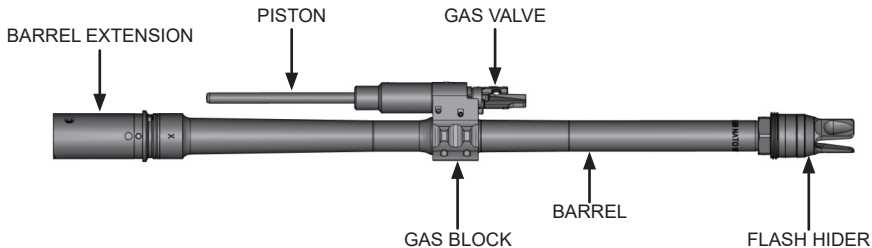

#### D. Handguard Assembly

The SIG MCX-SPEAR LT handguard assembly is comprised of the handguard and the handguard link. The handguard features multiple M-LOK points for mounting M-LOK accessories.

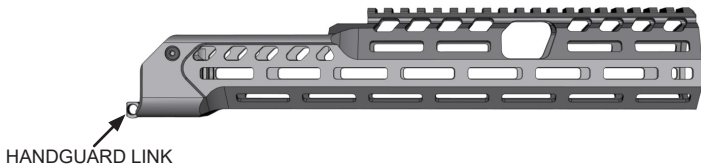

**WARNING PHYSICAL INJURY/DAMAGE**



**YOU MUST MAKE SURE THAT WHEN CHANGING BARRELS AND HANDGUARDS, THE FLASH HIDER, MUZZLE BRAKE, OR SUPPRESSOR MUST BE EXPOSED FROM THE END OF THE HANDGUARD. FAILURE TO DO SO COULD RESULT IN INJURY TO THE OPERATOR AND OR DAMAGE TO THE RIFLE.**



## 2.4.2 LOWER RECEIVER GROUP

The Lower Receiver Group consists of the following assemblies: Lower Receiver Assembly with Fire Control Components, Buttstock Assembly, Cheek Rest and Grip Assembly.





### A. Lower Receiver Assembly

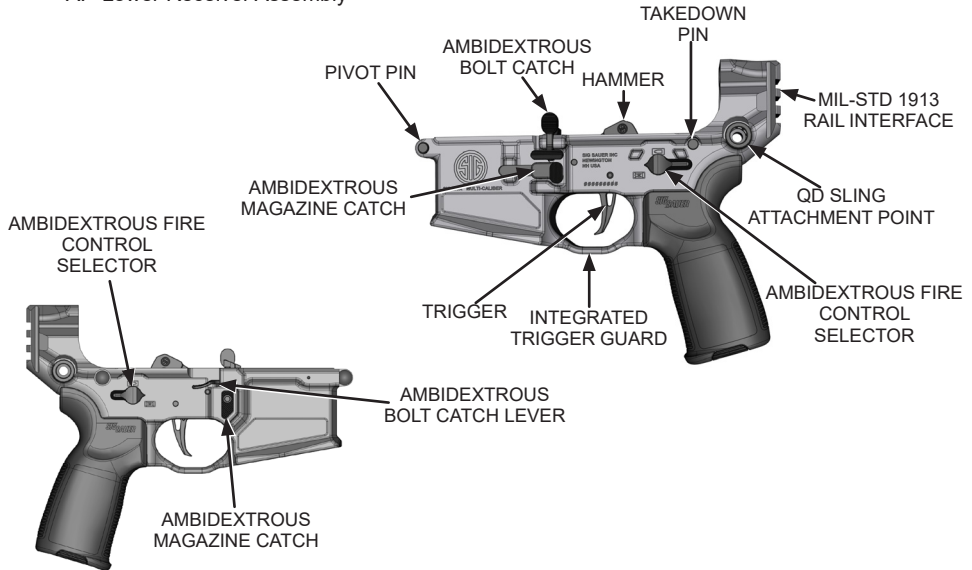



## **2.5 CYCLE OF FUNCTION**

There are eight steps in the cycle of function of the SIG MCX-SPEAR LT which begin after a loaded magazine is inserted into the firearm.

### **FEEDING**

As the bolt carrier is released from its rearward position, the carriage assembly moves forward allowing the lower lugs of the bolt to make contact with the rear of the cartridge as it sits in the magazine. The cartridge is stripped from the magazine and begins forward movement toward the chamber.

### **CHAMBERING**

As the bolt moves forward, the bolt locking lugs move forward into the barrel extension. The ejector is compressed against the left side of the cartridge head. The extractor snaps over the rim of the cartridge case.

### **LOCKING**

The movement of the bolt and the cartridge is stopped by the chamber. The bolt carrier continues forward movement until it is stopped by contact with the rear face of the barrel extension. As the carrier goes through the last portion of movement, the bolt is rotated to the left, through the action of the cam pin. The bolt lugs engage the barrel extension lugs to lock the bolt into the barrel extension.

### **FIRING**

The selector is rotated to the Semi position. The trigger is pressed releasing the hammer. The hammer spring drives the hammer forward unlocking the firing pin. The firing pin strikes the cartridge primer, causing detonation.

**UNLOCKING**

As the bullet passes the gas port in the barrel, a small amount of gas is bled off, traveling up through the gas port and into the gas block. The gas is regulated by the gas valve and is based on the type of ammunition being fired. This gas acts upon the piston to move the recoil assembly to the rear. The recoil assembly transfers its energy to the carrier assembly setting it in motion. The rearward movement of the carrier causes the bolt cam pin to rotate the bolt to the unlocked position.

**EXTRACTION**

As the bolt carrier assembly moves rearward the spent case is pulled free from the chamber by the extractor. The twisting motion of the bolt aids in the extraction from the chamber.

**EJECTION**

The extractor continues to grip the rim of the spent case on the right side. The ejector is applying forward pressure to the left side of the case. As the expended case clears the chamber, then the barrel extension, it is flipped out through the ejector port on the right side of the receiver.

**COCKING**

The rearward movement of the bolt carrier overrides the hammer, forcing it down into the receiver and compressing the hammer spring, cocking the hammer into the firing position.



## **3.0 OPERATING THE SIG MCX-SPEAR LT**

### **3.1 PREPARATION BEFORE USING THE FIREARM.**

Ensure you have read, understand, and are capable of following all the safety warnings on pages 2-20 of this manual in addition to the safety rules, regulations, procedures or guidelines of your club or local shooting range.

Prior to using the firearm it is strongly suggested to,

- Field strip the firearm. See section, “4.1 Field Strip the SIG MCX-SPEAR LT” on page 50.
- Clean any fouling that might have occurred during factory testing See section. “5.0 Cleaning and Lubrication” on page 78.
- Inspect/Lubricate, and re-assemble the firearm. See section, “5.3 Lubrication” on page 82.
- Upon re-assembly and prior to firing the rifle, conduct the Function Check. See section, “7.0 Function Check” on page 94.

Any maintenance beyond the user level described in this manual is to be performed by a professional gunsmith or certified SIG SAUER Armorer specifically trained on the maintenance of the SIG MCX-SPEAR LT in accordance with the SIG SAUER MCX-SPEAR LT Technical Armorer’s Manual.

## 3.2 SELECTING MODES OF FIRE

The SIG MCX is available in two fire control configurations. SAFE-SEMI and SAFE-SEMI-AUTO. Modes of fire are selected by rotating the selector lever to the desired position. The SAFE position prevents the firearm from firing by blocking the action of the trigger. The SEMI position is for the semi-automatic mode and allows the firing of one round each time the trigger is pressed rearward. AUTO, if so equipped, allows for a continuous rate of fire until the trigger is released by the operator, or the magazine is depleted of ammunition.

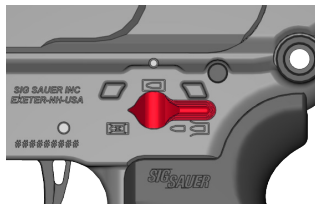

SAFE

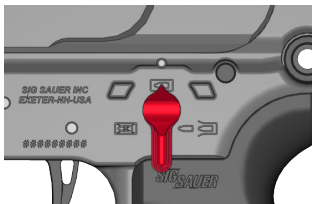

SEMI



AUTO



### 3.3 CLEARING THE SIG MCX-SPEAR LT

1. Ensure the muzzle of the firearm is pointed in a safe direction at all times while clearing the firearm.
2. Remove the magazine from the firearm by pressing the magazine catch and simultaneously pulling the magazine from the receiver.



3. Push up on right bolt catch or inward on bottom of left bolt catch, and hold in place.
4. Pull charging handle completely to rear and release. Bolt carrier assembly will remain locked to rear.
5. Return charging handle to forward locked position.
6. Rotate fire control selector to SAFE.

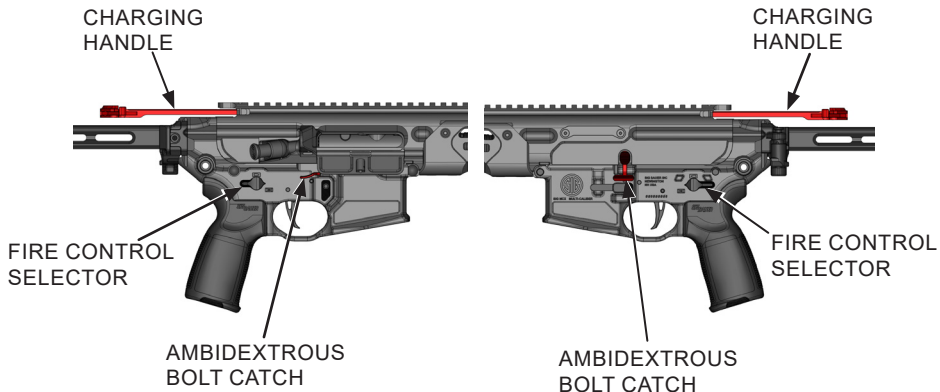



## WARNING PARTS UNDER SPRING TENSION



**THE BOLT CARRIER ASSEMBLY IS UNDER SPRING TENSION AND WILL SPRING FORWARD IF THE BOLT CATCH IS PRESSED, WHICH MAY CAUSE INJURY. THE CHAMBER OF THE FIREARM COULD POTENTIALLY BE HOT, WHICH MAY CAUSE BURNS. TO PREVENT INJURY WHEN PHYSICALLY INSPECTING THE CHAMBER DO NOT ALLOW THE BOLT CATCH TO BE PRESSED AND USE A PEN OR SIMILAR TOOL IF YOU ARE NOT SURE IF THE CHAMBER IS COLD.**

7. Inspect the chamber, bolt face, and magazine well to ensure that there are no live rounds or spent cartridges present.

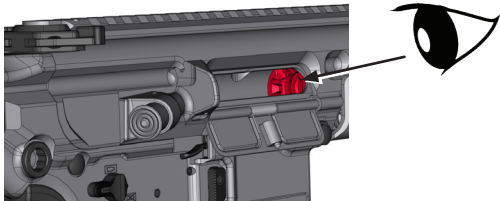

8. If passing the firearm to another person, allow that person to inspect the chamber before handling the firearm. Pass the firearm with the bolt locked to the rear and the fire control selector on SAFE.



**PAGE INTENTIONALLY LEFT BLANK**



## **3.4 LOADING/RELOADING**

### **3.4.1 LOADING/BOLT LOCKED TO THE REAR**

1. Rotate the fire control selector to the SAFE position.
2. Visually and physically inspect the chamber, bolt face, and magazine well to ensure it is clear.
3. Insert a loaded magazine until it engages and is held by the magazine catch. Always pull down to ensure the magazine is seated properly.
4. Press right bolt catch downward or, top of left bolt catch inward to release the bolt carrier. If the firearm is not to be fired immediately close the ejection port cover.

### **3.4.2 LOADING/BOLT FORWARD**

1. Insert a loaded magazine until it engages and is held by the magazine catch. Always pull down to ensure the magazine is seated properly.
2. Grasp the charging handle and pull it completely to the rear.
3. Release the charging handle, allowing it to move forward under full spring pressure chambering a live cartridge. (DO NOT RIDE IT FORWARD) .

### **3.4.3 RELOADING (EXPENDED MAGAZINE/BOLT LOCKED TO THE REAR)**

1. Rotate the fire control selector to SAFE.
2. Press the magazine catch from either the left or right side. The magazine should fall free from the magazine well.
3. Insert a loaded magazine until it engages and is held by the magazine catch. Pull down to ensure the magazine is seated properly.
4. Press the right bolt catch downward or, top of left bolt catch inward to release the bolt carrier chambering a live cartridge.

### **3.4.4 RELOADING (MAGAZINE PARTIALLY EXPENDED/BOLT FORWARD, LIVE ROUND CHAMBERED)**

1. Rotate the fire control selector to SAFE.
2. Grasp the magazine with the support hand and press the magazine catch from either the left or right side.
3. Remove the partially loaded magazine and secure it.
4. Insert a loaded magazine until it engages and is held by the magazine catch. Pull down to ensure the magazine is seated properly.



### 3.5 FIRING

**SEMI:** When the safety selector is rotated to this position, one press of the trigger will result in a single round being fired. The trigger must be released to reset.

**AUTO:** When the safety selector is rotated to this position, pressing the trigger will result in continuous fire at the cyclic rate until the trigger is released or the magazine is depleted of ammunition.

#### **To fire the SIG MCX:**

1. Deploy the buttstock, if not already done.
2. Insert a loaded magazine into the magazine well, charge the firearm and place on SAFE.
3. Face the target, placing the firearm to your shoulder.
4. Rotate the safety selector from SAFE to SEMI or AUTO.
5. Pressing the trigger releases the hammer causing the cartridge to be fired.

### 3.6 TWO-POSITION GAS VALVE

The SIG MCX-SPEAR LT is equipped with a two-position gas valve. This gas valve assembly regulates the function of the MCX-SPEAR LT by metering the amount of gas that is required for the firearm to function. This value allows for suppressed and unsuppressed operation. The adjustment is made by pushing the lever down on the appropriate side of the handguard.

## CAUTION

.300 BLK MODELS ARE NOT DESIGNED TO FUNCTION RELIABLY WITH SUB-SONIC AMMUNITION WHEN FIRED WITHOUT A SUPPRESSOR. IT IS POSSIBLE FOR SOME MODELS TO FUNCTION WITH SUB-SONIC AMMUNITION, HOWEVER THE POTENTIAL FOR STOPPAGES IN THE CYCLE OF OPERATION IS SIGNIFICANTLY INCREASED. FIRING THE RIFLE WITH ALL AMMUNITION TYPES WITH THE GAS VALVE IN THE (+) POSITION WILL NOT GUARANTEE RELIABLE FUNCTION. THIS WILL INCREASE THE BOLT CARRIER SPEED RESULTING IN REDUCED PARTS LIFE, FAILURES TO FEED AND FAILURES TO EJECT.

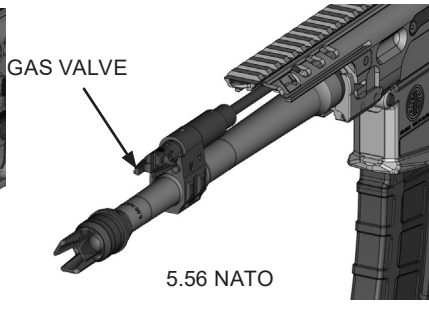
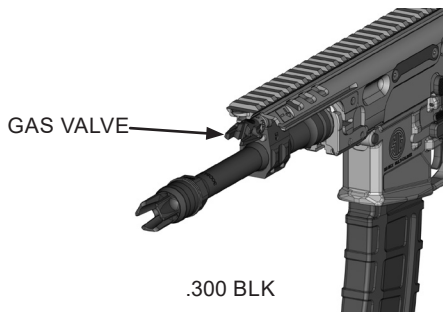

<b>GAS VALVE SETTINGS 5.56 NATO</b>	
<b>- SETTING (LEFT SIDE DOWN)</b>	<b>+ SETTING (RIGHT SIDE DOWN)</b>
STANDARD AMMUNITION SUPPRESSED AND UNSUPPRESSED	ADVERSE CONDITION / LOW FUNCTION AMMUNITION
<b>GAS VALVE SETTINGS 7.62x39mm</b>	
STANDARD AMMUNITION SUPPRESSED AND UNSUPPRESSED	ADVERSE CONDITION / LOW FUNCTION AMMUNITION
<b>GAS VALVE SETTINGS .300BLK</b>	
SUPERSONIC AMMUNITION SUPPRESSED AND UNSUPPRESSED	SUBSONIC SUPPRESSED, SUPERSONIC UNSUPPRESSED, ADVERSE CONDITION

## **3.7 ADVERSE/SPECIAL CONDITIONS**

### **Desert (Hot/Dry)**

- Apply light lubrication to internal metal-on-metal moving parts only. If available use dry graphite lubricant.
- Increase frequency of inspection and cleaning of firearm due to blowing dust and sand. Use muzzle covers if available.
- Unload and clean ammunition and inside of magazines daily. Do not lubricate magazine.
- Cover firearm when not in use.
- Close the ejection port cover when not in use.

### **Arctic (Extreme Cold/Sub-Freezing)**

- When operating in sub-freezing temperatures, use a lubricant designed for use in this climate. Do not use CLP, as it can prevent the firearm from firing. Ensure that all existing lubricants are thoroughly removed prior to applying cold weather lubricant.
- Avoid bringing firearm into heated shelters or buildings to prevent condensation from forming on moving parts which will freeze when the firearm is brought back outdoors.
- If you must bring the firearm indoors, allow it to warm to room temperature and then disassemble and clean thoroughly, ensuring that all moisture is removed from the firearm. Re-lubricate the firearm.
- When operating in snowy environments, conduct frequent inspection of the firearm to ensure that snow has not gotten into operating parts. Work the action to ensure it is not frozen. Use muzzle covers if available.



- If the carriage assembly becomes frozen with snow/moisture, DO NOT discharge the firearm to free the carriage. Warm the firearm using body heat or bring indoors until free movement is restored, and then clean and re-lubricate the firearm.

### **Jungle (Hot/Humid)**

- Increase frequency of inspection and cleaning of the firearm for rust/corrosion.
- Apply thin coat of lubricant on steel parts frequently.
- Inspect hidden surfaces of bolt and carriage assembly, upper receiver, chamber and barrel extension (locking lugs).
- Inspect the lower receiver for corrosion.
- Inspect and lubricate the spring-loaded detents of the firearm.
- Unload magazine, clean ammunition, and inspect the inside of magazines daily for corrosion.
- Wipe ammunition dry before reloading.



### 3.8 STOPPAGES

**If the SIG MCX-SPEAR LT stops firing apply immediate action:**

1. Slap up on the bottom of the magazine.
2. Pull charging handle completely rearward.
3. Observe the ejection of the case/cartridge and check the chamber for any obstruction.
4. Release the charging handle to feed a new cartridge.
5. Tap the forward assist to ensure the round is chambered and the bolt is locked.
6. Press the trigger and attempt to fire the rifle.

**If the SIG MCX-SPEAR LT still fails to fire upon completion of the above steps apply remedial action:**

1. Check the chamber for a stuck case.
2. If a case is present, separate the receivers and remove the entire carriage assembly.
3. Attempt to tap out the case with cleaning rod from the muzzle end of the barrel. If the firearm still fails to fire, refer to the troubleshooting section of this manual.



## 4.0 USER LEVEL AUTHORIZED PREVENTIVE MAINTENANCE

### 4.1 FIELD STRIP THE SIG MCX-SPEAR LT

1. Unload and clear the firearm. Ensure the fire control selector is on SAFE.
2. Remove the sling if attached.
3. Push the takedown pin from left to right until stopped by detent.

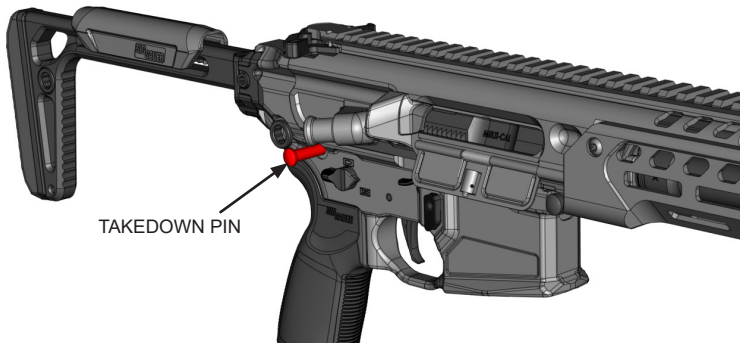

4. Swing apart receivers.

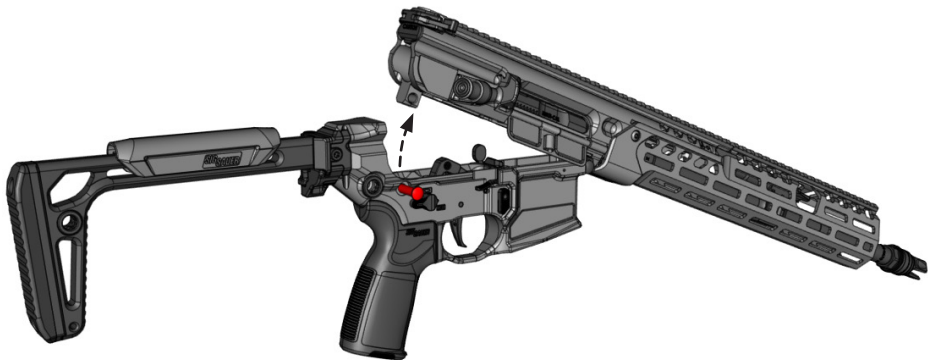



5. Pull the charging handle rearward until it stops.



6. Grasp the recoil spring plate and pull the carriage assembly from the upper receiver. It will come out as a complete unit.

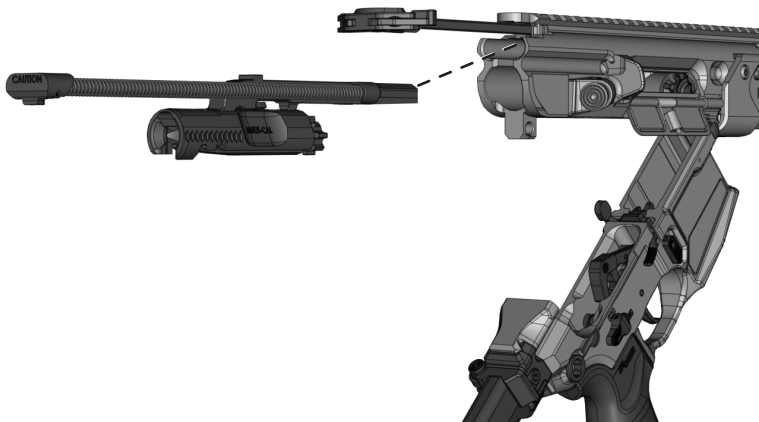



7. Remove the charging handle.



8. Close the receivers together and push the pivot pin from the left to right and separate the receivers.

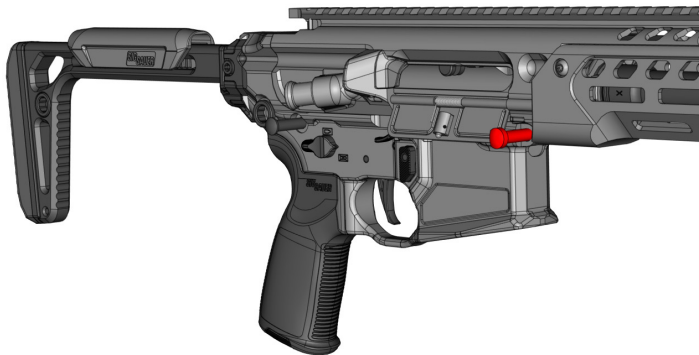



9. Rotate the recoil assembly upward and slide it out from the left side of the bolt carrier.

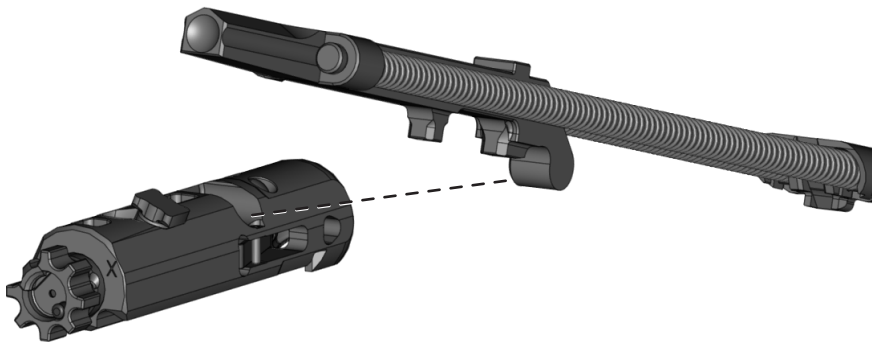



10. Pull the firing pin retaining pin out until it stops.

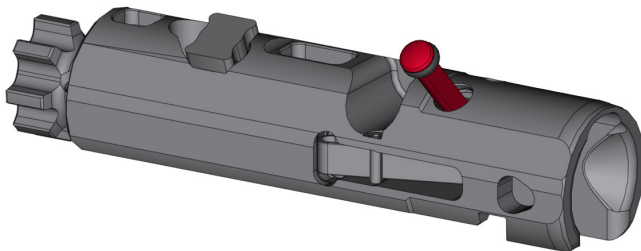



11. Using a 1/16 inch pin punch, press the firing pin latch outward past the large flange of firing pin. Tilt bolt carrier downward and let the firing pin and spring fall from carrier.

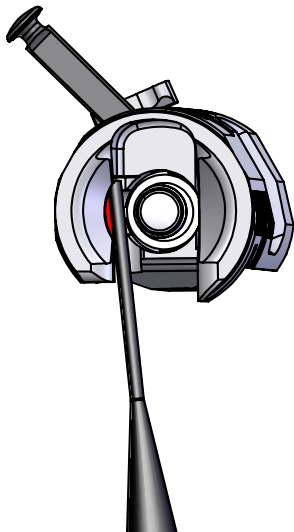

12. Pull the cam pin from the bolt and remove the bolt from the front of the carrier.

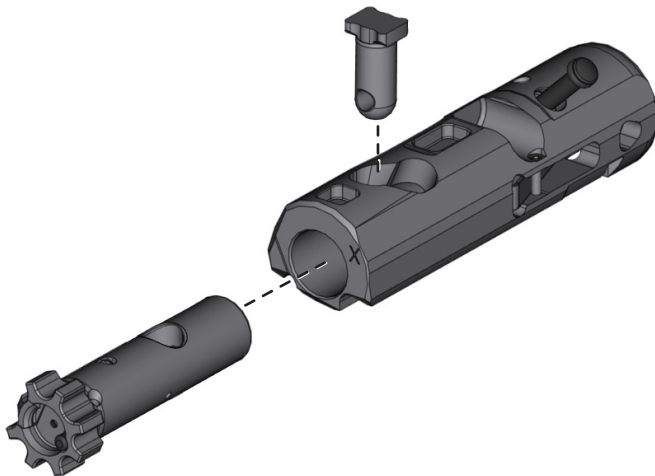



13. Push the extractor pin out and remove the extractor from the bolt. Do not remove the O-ring, extractor spring, or the extractor insert unless replacement is necessary.

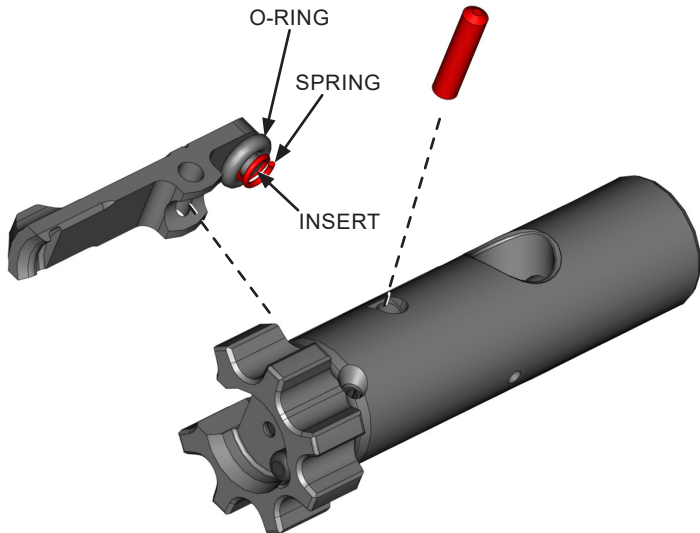

**PAGE INTENTIONALLY LEFT BLANK**



## 4.2 HANDGUARD REMOVAL

1. Use a T15™ drive bit to remove the screws from rear of both sides of handguard.

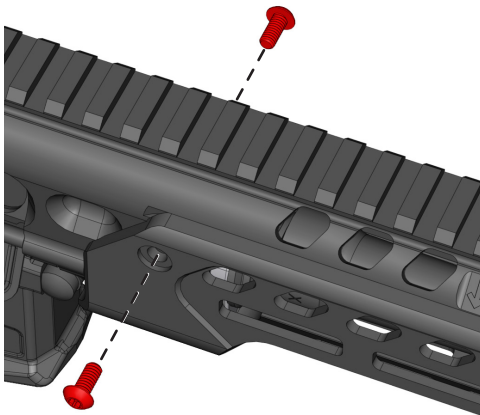

2. Pull the pivot pin out to the detent then pull the handguard forward off of the upper receiver.

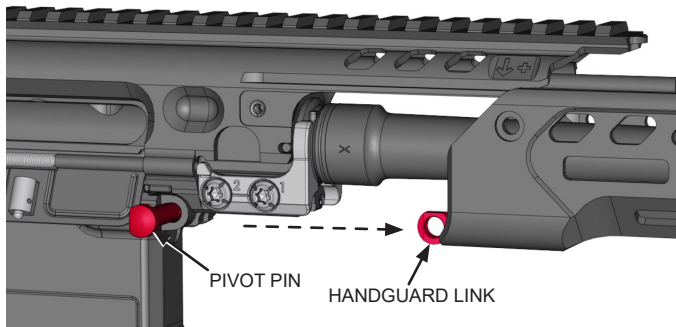



## 4.3 HANDGUARD INSTALLATION

1. Slide rear of handguard onto rails of upper receiver, then push pivot pin into lower receiver to retain.

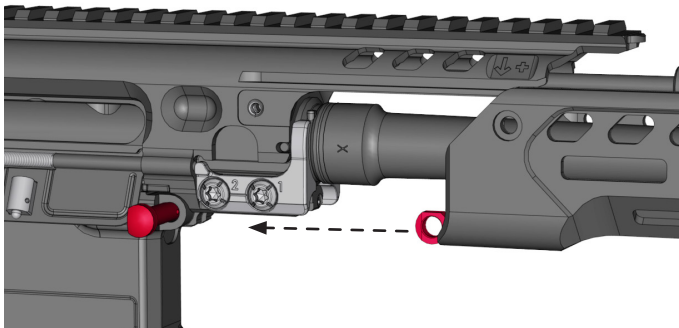



2. Use a T15 drive bit to install handguard screws through holes in handguard and into holes upper receiver..

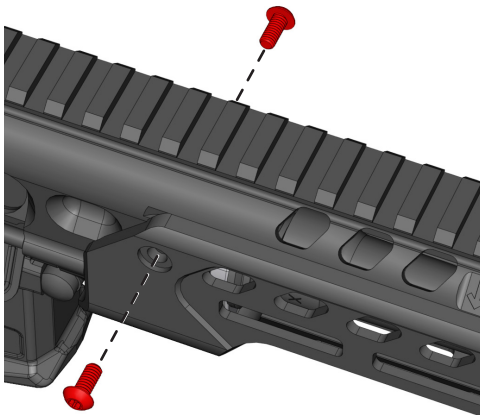



## 4.4 GAS VALVE AND PISTON REMOVAL

1. Press the stop pin.
2. Rotate the gas valve until the flange on the valve is fully exposed allowing the valve to be pulled out of the gas block.
3. Remove the gas valve and the piston from the front of the gas block.

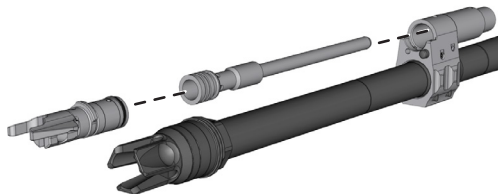
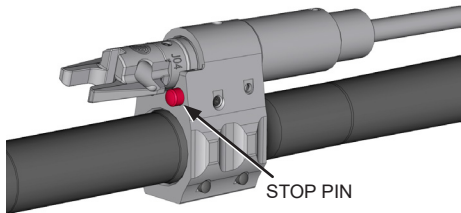

.300 BLACKOUT



7.62X39



5.56 NATO

## 4.5 GAS VALVE AND PISTON INSTALLATION

1. Insert piston into front opening of gas block until it is fully seated.
2. Align flange of gas valve upward and insert gas valve into front opening of gas block until flange is seated.
3. Press stop pin and turn gas valve until retained by stop pin.

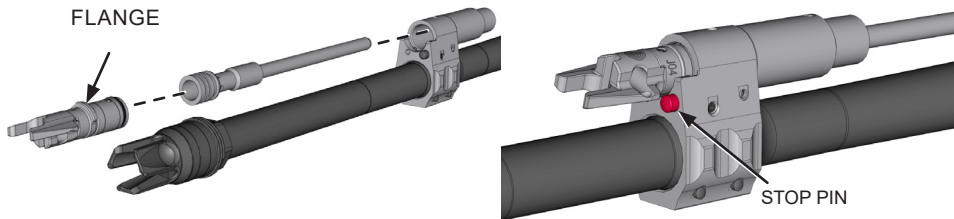



## 4.6 BARREL REMOVAL

### NOTE

The carriage assembly must be removed prior to removing the barrel. See section, “4.1 Field Strip the SIG MCX-SPEAR LT” on page 50. The barrel clamping screws are captive to the upper receiver and only require loosening to remove barrel.

1. Using a T27™ drive bit, loosen the two barrel clamping screws from the right side of the upper receiver. These screws are captive and will not be removed from the receiver.

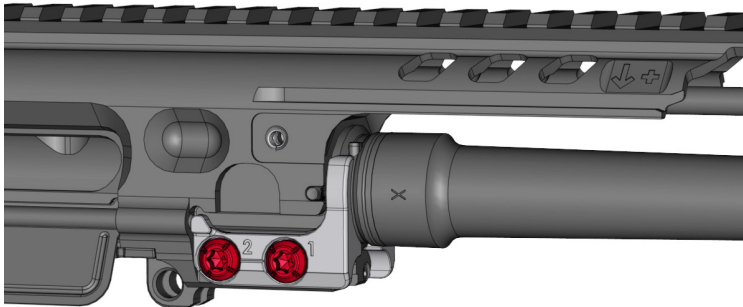

2. Pull the barrel straight out of the upper receiver. Do not wiggle it back and forth, as this can damage the upper receiver. If the barrel will not pull free, use a 1 inch wooden dowel inserted in through the rear of the upper receiver and then tap out the barrel.

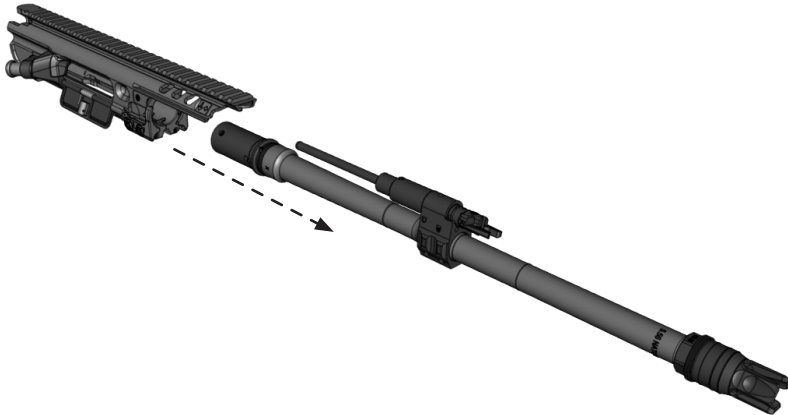



## 4.7 BARREL INSTALLATION

1. Ensure that all mating surfaces are clean.
2. Check the barrel index pins for damage or looseness.
3. Slide the barrel assembly back into the upper receiver, making sure the index pins are engaged properly into the upper receiver.
4. Ensure both left and right index pins are seated completely into upper receiver. Pinch the left and right clamp together until they contact the upper receiver. Using a T27 Torx wrench, tighten the screws, alternating back and forth between screw #1 and screw #2, until they are just hand tight. Start with screw #1 and apply a torque of 60 lb-in. Move to screw #2 and apply torque of 60 lb-in. Return to screw #1 and tighten again to ensure that the screw is at 60 lb-in.
5. Reinsert the bolt carrier assembly and ensure that the bolt locks up properly.

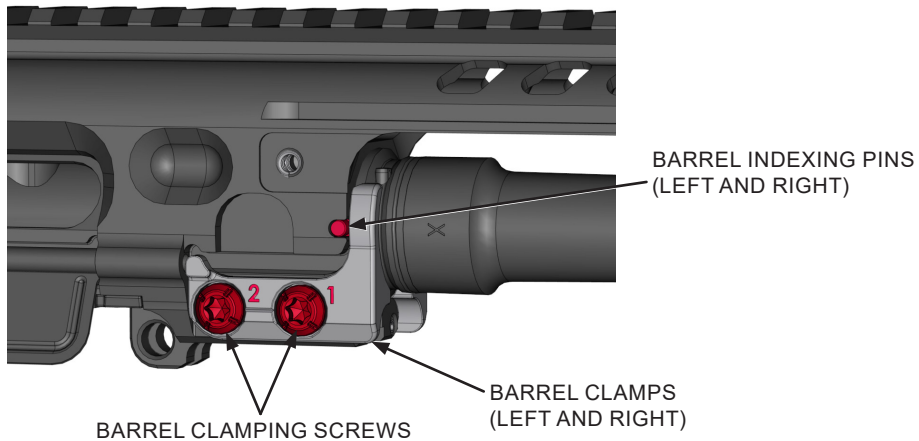



## 4.8 FOLDING STOCK REMOVAL

1. Loosen clamp screw with a T27 wrench then slide stock off rear of receiver.

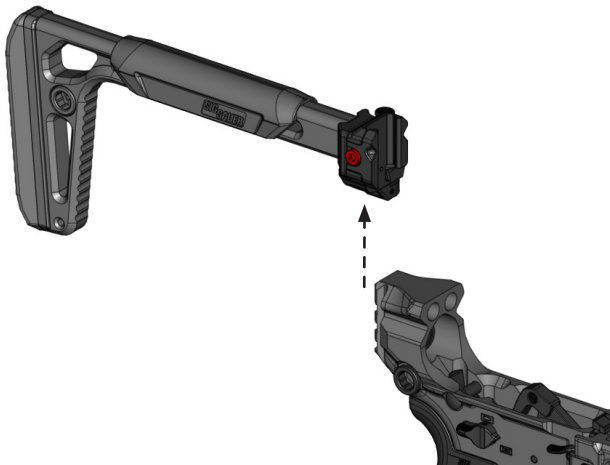



## 4.9 FOLDING STOCK INSTALLATION

1. Position stock onto rear of receiver then tighten clamp screw with a T27 until snug plus 1/4 turn.
2. Check the folding function as described in “8.1 Lightweight Skeletonized Folding Stock” on page 96.

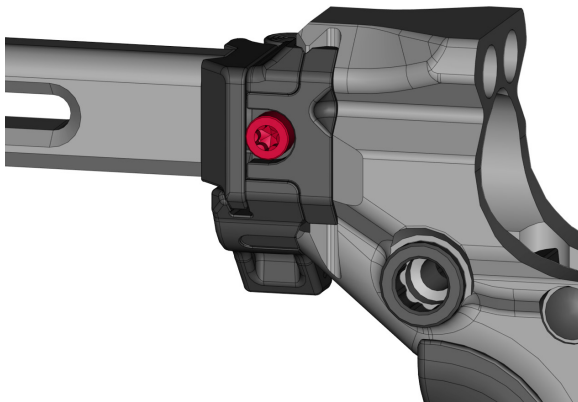



## 4.10 CHEEK REST REMOVAL

1. Slide cheek rest up and off of stock assembly.



2. Remove cheek rest locking insert from stock assembly.

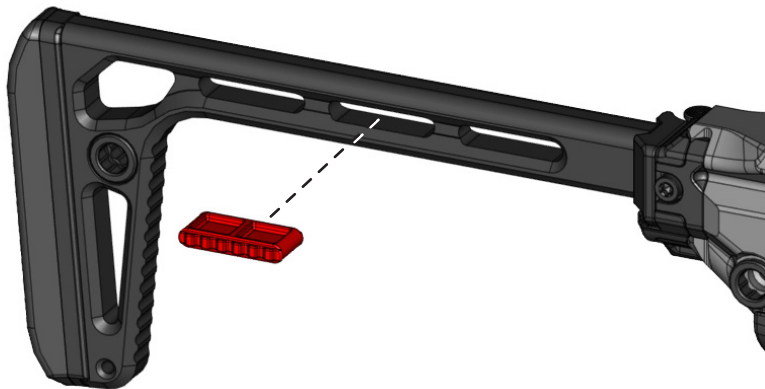



## 4.11 CHEEK REST INSTALLATION

1. Install cheek rest locking insert into slot in stock assembly.



2. Slide cheek rest down onto stock assembly until it is retained by the locking insert.





## 5.0 CLEANING AND LUBRICATION

- Use only cleaning and lubrication products specifically designed for use on firearms.
- Do not use wire brushes on aluminum surfaces such as the upper/lower receivers, because this can scratch the finish.
- Follow all manufactures instructions and cautions when using cleaning and lubrication products.
- Wherever the term CLP (Cleaner-Lubricant-Protectant) or the words lube or lubrication are used in this manual, it is interpreted to mean that you can use any lubricant designed for use on firearms.
- Wherever propellant gases directly contact operating system parts, carbon will build up. Carbon cannot be removed with a brush and must be scraped.

## 5.1 CLEANING THE BORE AND CHAMBER

Do not run patches through the bore with a sound suppressor attached.

1. Attach the proper caliber jag to the cleaning rod.
2. Moisten a patch with CLP and slowly push it through the bore toward the muzzle end.
3. Allow the CLP to stay in the barrel for several minutes to loosen any fouling.
4. Attach a new clean patch to the cleaning rod.
5. Coat the patch as before and push it through the bore
6. If heavy fouling is present, use a bore brush to scrub the bore.
7. Push a patch through the bore with CLP to remove any residue loosened by the bore brush.
8. Push new patches through the bore until they come out clean.
9. Coat the chamber brush with CLP.
10. Keep the muzzle elevated so the CLP does not run into the freshly cleaned bore.
11. Make several plunging strokes followed by several 360 degree rotations in the barrel extension to clean the locking lug area.



## 5.2 CLEANING THE OPERATING SYSTEM

Under normal operating conditions, the MCX-SPEAR LT bolt does not require as much cleaning as an M4 bolt. However, when used with a suppressor attached, the back pressure will produce more residue, which will require attention.

- A. Clean bolt body with solvent.
- B. Clean any carbon from bolt lugs.
- C. Clean hood of extractor.
- D. Clean recoil spring rods.
- E. Clean recoil springs.
- F. Clean the recoil assembly paying attention to residue buildup on the lug that engages the bolt carrier.
- G. Clean the cam pin of carbon build up.
- H. Clean the recoil assembly interface of the bolt carrier.
- I. Wipe down the firing pin and spring.
- J. Wipe down the bolt carrier body.
- K. Clean the bolt channel of any carbon buildup.
- L. Clean the gas valve of any residue and remove carbon.
- M. Remove carbon buildup from piston.



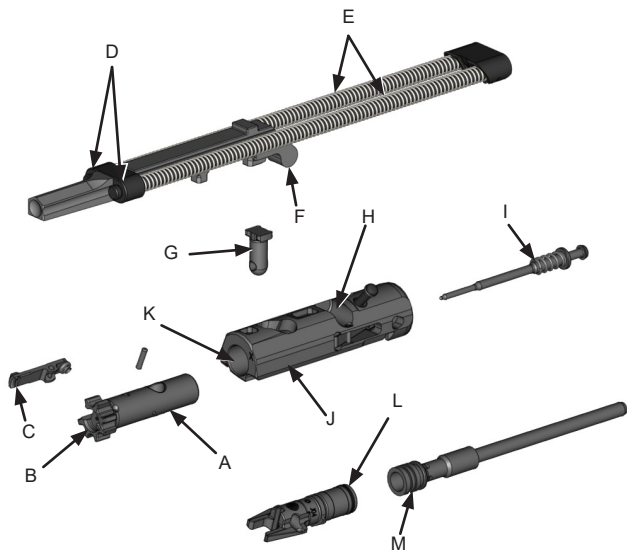



## 5.3 LUBRICATION

### Carriage Assembly

- A. Apply 1 to 2 drops of lubricant where the recoil assembly contacts the spring guide, the recoil plate, bolt carrier, and firing pin lock
- B. Apply a thin film of lubricant to the spring guide rods and recoil springs
- C. Apply a thin coat of lubricant to the back of bolt lugs, bolt body, and cam pin hole.
- D. Apply a thin coat of lubricant to the bolt carrier contact surfaces.
- E. Apply 1 to 2 drops of lubricant to the cam pin.
- F. Do not lubricate the face of the bolt.
- G. Apply 1 to 2 drops of lubricant to gas block vent hole.

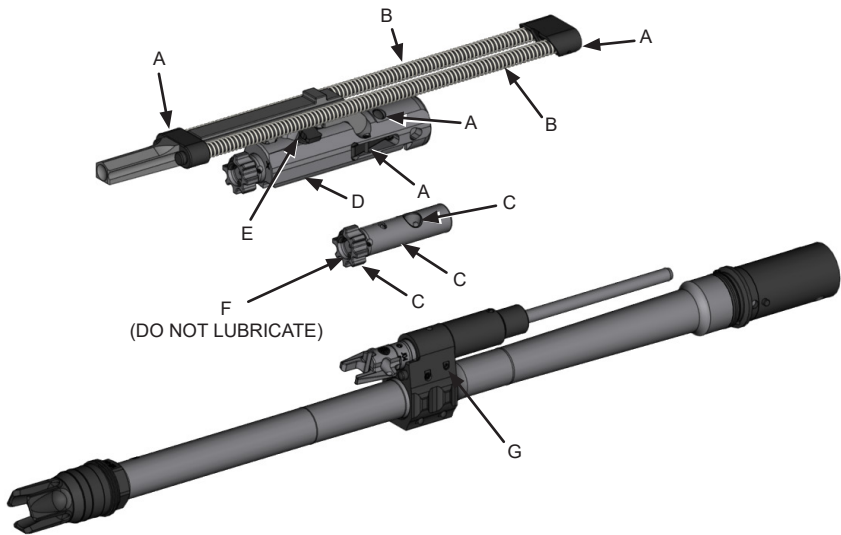



## Upper Receiver

- A. Apply a thin film of lubricant to the inside of the upper receiver to the surfaces where the carriage assembly makes contact.
- B. Apply a thin film of lubricant to the sides of the charging handle.
- C. Apply 1 to 2 drops of lubricant to the charging handle latches.

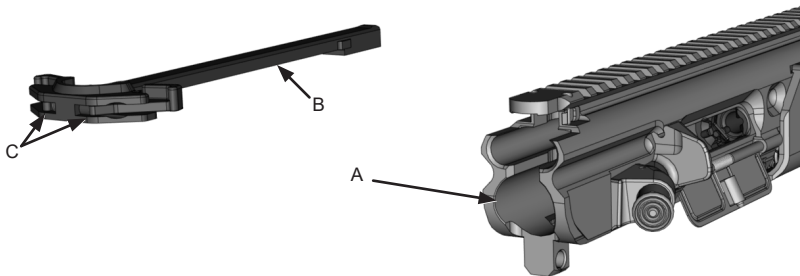

### Lower Receiver

- A. Apply 1 to 2 drops of lubricant to the hammer, trigger, and bolt catch where these parts contact their respective pins.
- B. Apply 1 to 2 drops of lubricant to the selector where it contacts the lower receiver.
- C. Apply 1 to 2 drops of lubricant to pivot and takedown pins.

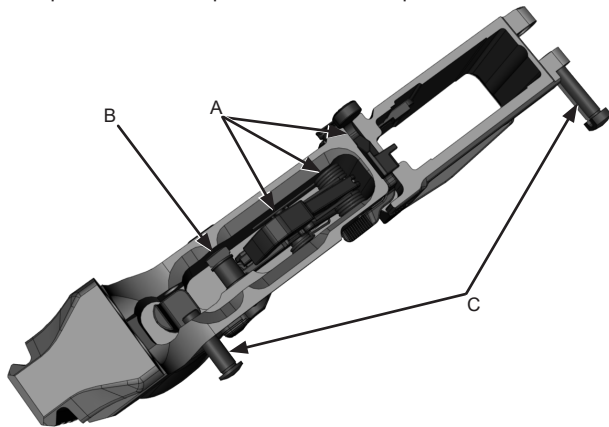



## 6.0 REASSEMBLY

1. Place extractor in extractor slot of bolt body then insert extractor pin into bolt until extractor is retained and pin is flush with surface of bolt.

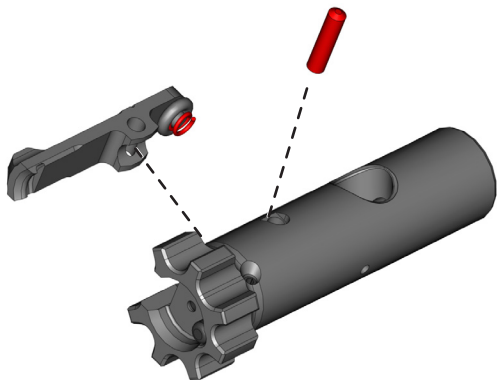

2. Insert bolt into bolt carrier with extractor positioned as shown below.

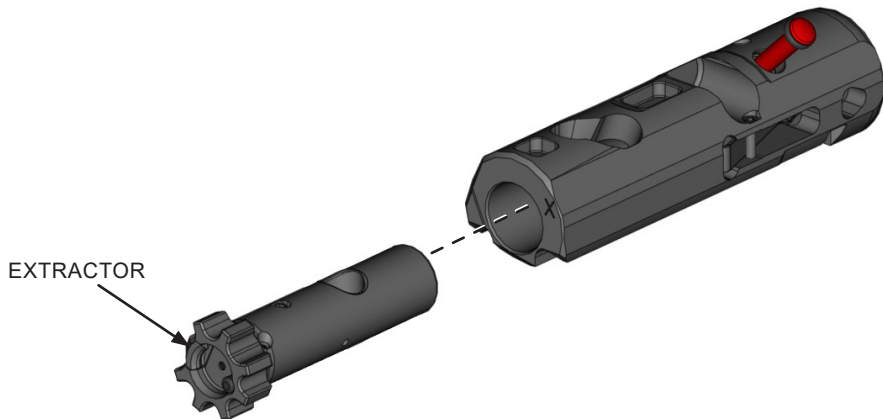



## **WARNING PHYSICAL INJURY/DAMAGE**



**FAILURE TO INSTALL CAM PIN MAY RESULT IN INJURY OR DEATH TO THE USER AND CATASTROPHIC DAMAGE TO THE FIREARM.**

3. Insert the cam pin and align the firing pin through hole to the firing pin bore.

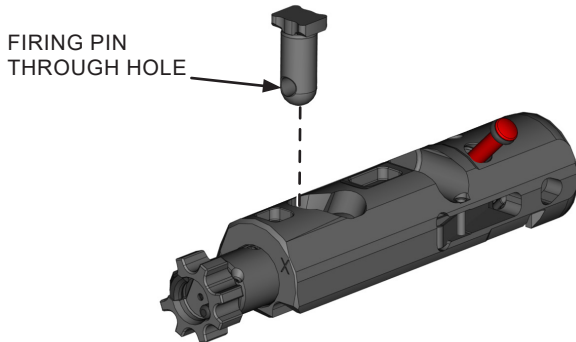



- Using a 1/16 inch pin punch, press the firing pin latch outward to clear the path for the firing pin. Tilt bolt carrier and insert the firing pin and spring into the rear of the bolt until it stops. Then release the firing pin latch.

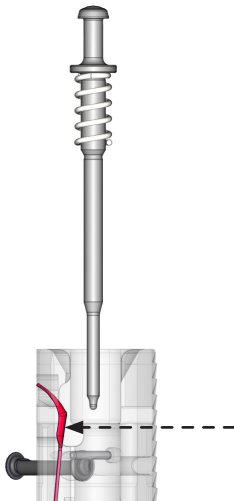



5. Push in on the firing pin until it stops. Push the firing pin retaining pin back into the bolt carrier. The firing pin retaining pin must be positioned between the large flange of the firing pin and the firing pin head and the head of firing pin must be captured by the firing pin lock.

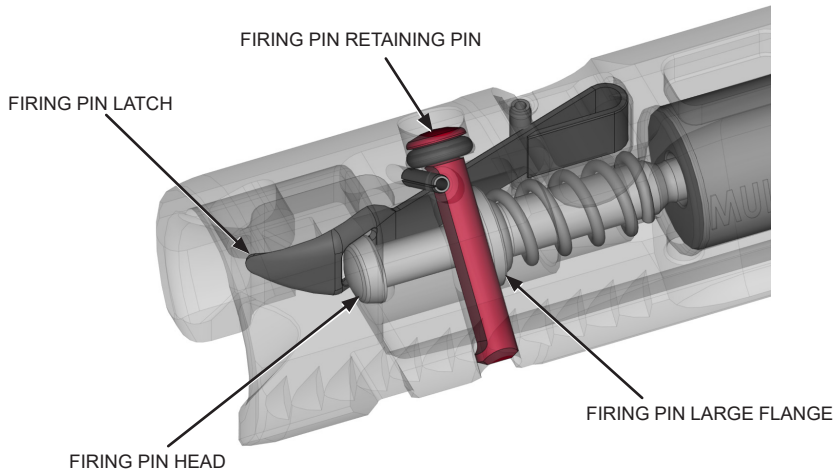

6. Install the recoil assembly into the carrier from the left side.

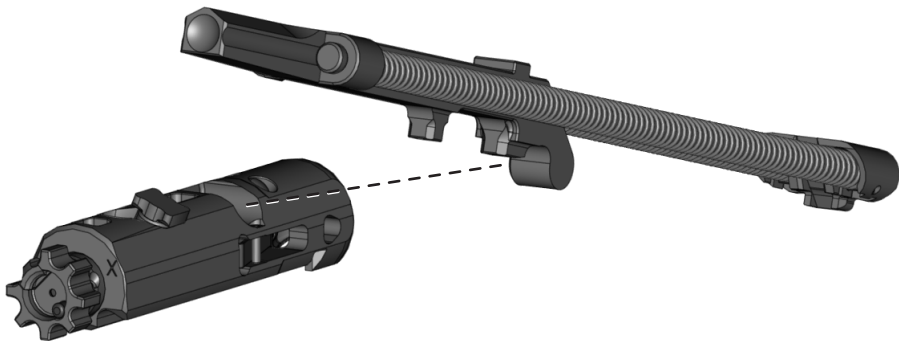



7. Attach the upper receiver to the lower receiver then push in the pivot pin until it stops.



8. Insert charging handle and carriage assembly into the upper receiver.



9. Close the receivers together and push the takedown pin in until it stops.



## 7.0 FUNCTION CHECK



**WARNING**

**UNLOAD/CLEAR**



**PRIOR TO STARTING THE FUNCTION CHECK ENSURE THE FIREARM IS UNLOADED/  
CLEARED AND ON SAFE WITH THE BOLT FORWARD AND LOCKED. FAILURE TO  
COMPLY COULD RESULT IN INJURY OR DEATH.**

1. Insert unloaded magazine into mag well and verify it is fully seated by pulling downward.
2. Pull charging handle completely to rear. Bolt must lock back on empty magazine. Push charging handle forward until it locks in place. Charging handle must lock forward.
3. Press magazine release. Magazine must fall free under its own weight.
4. Pull charging handle completely to rear. You should hear a slight click and visually see the bolt catch rotate upward. Release the charging handle allowing the bolt to go forward.
5. Press and hold the bottom of left bolt catch or up on right bolt catch while pulling the charging handle fully to the rear. The bolt should lock to the rear. Return the charging handle forward and press the bolt release located on the right side of upper receiver. Bolt should move forward and lock.
6. With muzzle pointed in a safe direction and fire control selector on SAFE, press trigger. Nothing should happen.

7. Rotate fire control selector to Semi (Fire) position, press and hold trigger to the rear. You should hear the hammer fall.
8. With the trigger still held rearward, pull charging handle completely to rear and release. Slowly release the trigger. You should hear an audible click and feel sear reset.
9. Rotate the selector to AUTO (if applicable).
10. Pull the charging handle to the rear and release it.
11. Press the trigger and hold to the rear. You should hear a loud click as the hammer falls.
12. With the trigger still pressed to the rear, pull the charging handle to the rear and ease it fully forward. A loud click should be heard at the end of the travel.
13. Release the trigger.
14. No click should be heard as the hammer should have followed the bolt carrier forward.
15. Press the trigger. No click should be heard. Release the trigger.
16. Pull the charging handle fully to the rear and release one more time. Rotate the selector back to SAFE.



## 8.0 MCX-SPEAR LT STOCK

The MCX-SPEAR LT rifle ships with a lightweight, skeletonized stock attached. Other MCX stocks are available. All are designed to attach to the MIL-STD 1913 interface on the rear of the lower receiver.

### 8.1 LIGHTWEIGHT SKELETONIZED FOLDING STOCK

Push lock button then lift up on the stock to disengage the locking mechanism for folding.

To deploy the stock, just pull the stock outward and swing it back until it locks in place.

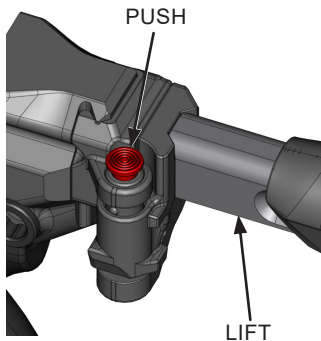



**PAGE INTENTIONALLY LEFT BLANK**



## 8.2 TROUBLESHOOTING

<b>Symptom</b>	<b>Possible Cause</b>	<b>Corrective Action</b>
<b><i>Fails to fire</i></b>	Selector on SAFE	Rotate to a fire position
	Improper installation of firing pin	Assemble correctly
	Excessive oil in firing pin recess of bolt	Clean
	Defective ammo	Remove/Discard
<b><i>Bolt fails to unlock</i></b>	Dirty bolt	Clean and reinstall
	Burred Bolt Lugs	Contact Customer Service
<b><i>Failure to feed</i></b>	Dirty/corroded ammunition	Clean or Replace
	Dirty magazine	Clean or Replace
	Defective magazine	Replace
	Overloaded magazine	Remove excess rounds
	Magazine not seated	Check mag catch adjustment
	Under function	Contact Customer Service
<b><i>Double feed</i></b>	Defective magazine	Replace

<b>Symptom</b>	<b>Possible Cause</b>	<b>Corrective Action</b>
<b><i>Failure to chamber</i></b>	Dirty/corroded ammunition	Clean or Replace
	Damaged ammunition	Discard/Replace
	Dirty chamber	Clean
<b><i>Bolt fails to lock</i></b>	Dirty bolt assembly	Clean Bolt and Extractor
	Damaged recoil assembly	Contact Customer Service
<b><i>Failure to extract</i></b>	Frozen extractor	Remove and Clean
	Broken extractor spring	Contact Customer Service
	Restricted movement of bolt carrier	Remove, Clean, and Lubricate
	Dirty/corroded ammunition	Clean or Replace
	Dirty chamber	Clean
<b><i>Fails to lock bolt to rear after last round</i></b>	Faulty magazine	Replace
	Broken bolt catch	Contact Customer Service
	Heavily fouled gas system	Clean gas system components
<b><i>Frozen selector lever</i></b>	Needs oil	Lubricate
	Dirt/Residue under trigger	Clean



### 8.3 UPPER RECEIVER ASSEMBLY PARTS DIAGRAM

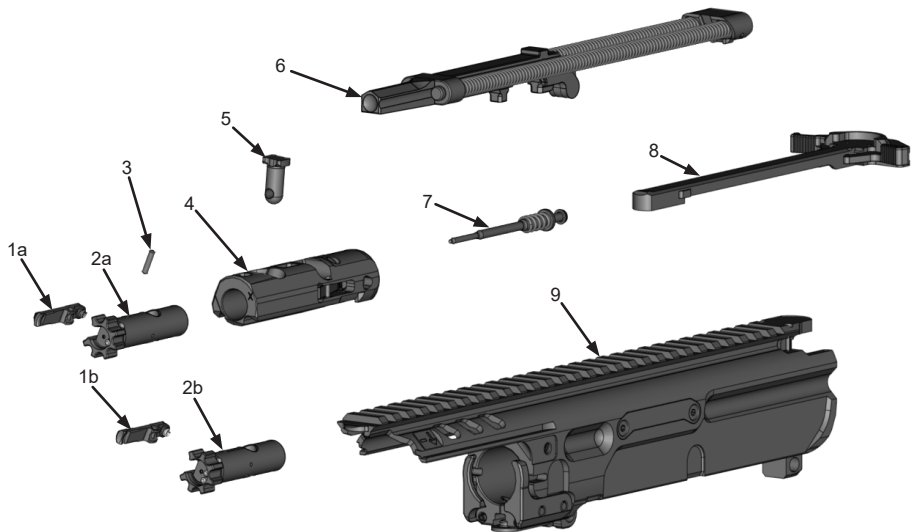

Number	Nomenclature
1	Extractor Assembly a. .300 BLK / 5.56 NATO b. 7.62x39 mm.
2	Bolt a. .300 BLK / 5.56 NATO b. 7.62x39 mm.
3	Extractor Pin
4	Bolt Carrier Assembly
5	Cam Pin
6	Recoil Assembly
7	Firing Pin and Spring
8	Ambidextrous Charging Handle
9	Upper Receiver Assembly



## 8.4 BARREL AND HANDGUARD ASSEMBLY PARTS DIAGRAM

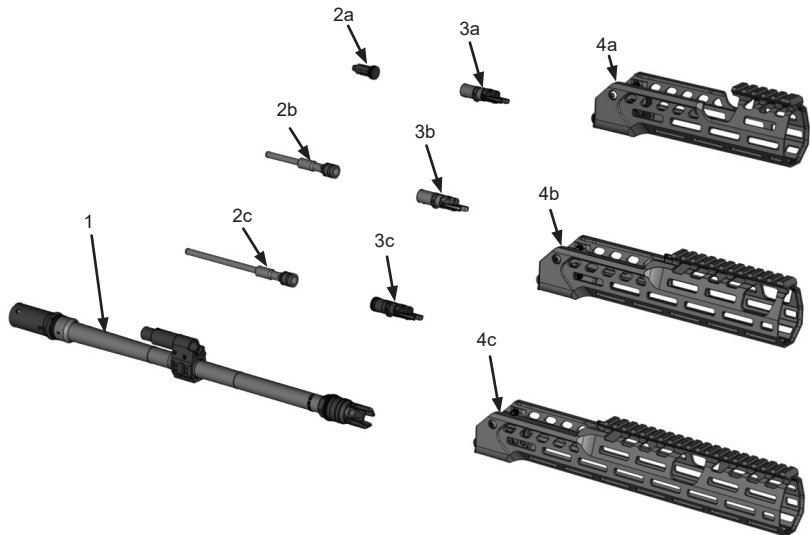

NUMBER	NOMENCLATURE
1	Barrel And Gas Block .300BLK (6.75 and 9 inch) 7.62x39 (11.5 and 16 inch) 5.56 NATO (9, 11.5, 14.5, and 16 inch)
2	Piston a. .300 BLK With Spiral Gas Ring b. 7.62x39 c. 5.56 NATO
3	Gas Valve, 2 Position a. .300 BLK b. 7.62x39 c. 5.56 NATO 11.5 in With Spiral Gas Ring
4	Handguard a. PDW b. Carbine Short c. Carbine Long



## 8.5 LOWER RECEIVER ASSEMBLY PARTS DIAGRAM





<b>Number</b>	<b>Nomenclature</b>
1	Light Weight Skeletonized Stock Assembly
2	Cheek Rest
3	Lower Receiver Assembly
4	PMAG AR/M4, 30 RD, GEN M3, 5.56X45 MAGAZINE, BLK
5	MAGAZINE, AR, 28 RD, 7.62 X 39, CPD, STAINLESS STEEL, BLK



## 9.0 TRANSPORTATION AND STORAGE



### WARNING

**NEVER PLACE OR STORE ANY FIREARM IN SUCH A MANNER THAT IT MAY BE DISLODGED. FIREARMS SHOULD ALWAYS BE STORED SECURELY AND UNLOADED, AWAY FROM CHILDREN AND OTHER UNAUTHORIZED USERS. THE USE OF A LOCKING DEVICE OR SAFETY LOCK IS ONLY ONE ASPECT OF RESPONSIBLE FIREARMS STORAGE. FOR INCREASED SAFETY, FIREARMS SHOULD BE STORED UNLOADED AND LOCKED IN A LOCATION THAT IS BOTH SEPARATE FROM THEIR AMMUNITION AND INACCESSIBLE TO CHILDREN AND ANY OTHER UNAUTHORIZED PERSON.**

#### **Short-Term Storage (90 days or less)**

1. Ensure the chamber and magazine do not contain live ammunition.
2. Clean the bore and chamber
3. Apply a generous coat of CLP to the chamber and bore.
4. Apply a light coat of CLP to all other metal surfaces for corrosion protection.
5. Do not attempt to store an MCX-SPEAR LT with a warm or hot silencer.

**Long-Term Storage (90 days or longer)**

1. Ensure the MCX-SPEAR LT is thoroughly cleaned.
2. Apply a medium coat of CLP to the chamber and bore.
3. Apply a light coat of CLP to all other metal surfaces for corrosion protection.
4. Wrap the MCX-SPEAR LT with a waterproof material (MIL-B-121 or similar).
5. Place the MCX-SPEAR LT in a corrosion resistant barrier bag (MIL-DTL-117 or similar).

**Environmental Storage Recommendations (Armory)**

Provide humidity control to limit the relative humidity to no greater than 40% at 80°F (26.7°C). If personnel will be working in these areas, design to 68°F (20.0°C) dry bulb and 40% RH for indoor design heating conditions, and 75°F (23.9°C) dry bulb and 40% RH for indoor design cooling conditions.



## **10.0 SERVICE AND REPLACEMENT PARTS POLICY**

### **Parts Policy**

Our Service Department maintains a full complement of replacement parts. Even though most gunsmiths have the knowledge, training, and the ability to make necessary repairs to your firearm, the skill and workmanship of any particular third-party gunsmith is totally beyond our control.

Should your firearm ever require service, we strongly recommend that you return it to SIG SAUER Inc. A firearm is a precision instrument and some replacement parts will require individual fitting to ensure correct operation. A wrong part, improper fitting, or incorrect mechanical adjustment may result in an unsafe condition or dangerous malfunction, damage to the firearm, or cause possible serious injury to the shooter or others

IF ANY PART IS ORDERED WITHOUT RETURNING THE FIREARM TO SIG SAUER Inc., the customer bears full responsibility for ensuring that the part supplied is correct for their particular firearm and is properly installed and fitted by a qualified gunsmith.

SIG SAUER INC. IS NOT RESPONSIBLE FOR THE FUNCTIONING OF ANY FIREARM IN WHICH REPLACEMENT PARTS ARE INSTALLED BY OTHERS.

### **Order Parts**

In the event you want to order parts for your SIG MCX-SPEAR LT rifle, contact Customer Service at (603) 610-3000 Ext. 1. Have available the serial number of your firearm and the part diagram number for the part(s) you wish to order. A parts list and diagram of the firearm is provided in Sections 5.7, and 5.8 of this manual. You may also visit [sigsauer.com](http://sigsauer.com) and use the small parts shopper on-line tool.

**WARNING PHYSICAL INJURY/DAMAGE**

**IT IS THE PURCHASER'S RESPONSIBILITY TO BE ABSOLUTELY CERTAIN THAT ANY PARTS ORDERED FROM THE FACTORY ARE CORRECTLY FITTED AND INSTALLED. FIREARMS ARE COMPLICATED MECHANISMS AND IMPROPER FITTING OF PARTS MAY RESULT IN A DANGEROUS MALFUNCTION, DAMAGE TO THE FIREARM, AND SERIOUS INJURY TO THE SHOOTER AND OTHER PERSONS. THE PURCHASER AND INSTALLER OF PARTS MUST ACCEPT FULL RESPONSIBILITY FOR THE CORRECT ADJUSTMENT AND FUNCTIONING OF THE FIREARM AFTER SUCH INSTALLATION.**

**Service Policy**

If you have questions concerning the performance or servicing of your firearm, please write or call:

SIG SAUER Inc.  
Attention Customer Service  
72 Pease Boulevard, Newington, NH 03801  
Phone: (603) 610-3000 Ext. 1  
Fax: (603) 766-7002

**IF YOU DO NOT UNDERSTAND THE INSTRUCTIONS FOR OPERATING YOUR FIREARM, IT IS YOUR RESPONSIBILITY TO CALL OUR CUSTOMER SERVICE DEPARTMENT AT (603) 610-3000 Ext. 1 BEFORE USING YOUR FIREARM.**



## 11.0 SHIPPING FIREARMS FOR REPAIR

### Returning Your Firearm for Service

In the event you need to return your firearm to the SIG SAUER Service Department, here's what to do:

1. The first step is to contact Customer Service at (603) 610-3000 for Return Merchandise Authorization (RMA) number. This number allows SIG SAUER to track the status of your return from its receipt at SIG SAUER through its return to you. Please do not send your firearm until you obtain an RMA number.
2. Make sure the chamber and magazine(s) are unloaded and that no ammunition is included with your returned firearm.
3. Package the firearm securely to prevent damage. Enclose a letter which includes your name, street address, daytime phone number, model and serial number, and a detailed description of the problem you are experienced or the work you want performed. With the exception of extra magazines, do not include scopes, mounts, or other accessories.
4. An individual's ability to legally ship firearms to the manufacturer for repair or service varies according to state and local law. Some jurisdictions require that firearms be shipped and returned by a Federally Licensed Firearms Dealer. Consult applicable law to determine how your firearm should be returned.

5. Federal law prohibits persons who do not possess a Federal Firearms License from shipping a firearm via the U.S. Postal Service. (Note: any shipment of firearms outside U.S. borders is subject to the export laws of the United States and to the valid laws of the specific country, which you must strictly follow: prior to exporting any firearm you should seek legal counsel.)
6. SIG SAUER is not responsible for any firearm until it is received, nor for damage incurred during shipment.
7. Ship your firearms insured and prepaid (we do not accept collect shipments) to:

SIG SAUER Inc.  
Attention: Service Department  
18 Industrial Drive Exeter, NH 03833



## **SIG SAUER® LIMITED LIFETIME FIREARMS WARRANTY**

SIG SAUER warrants that the enclosed firearm was originally manufactured free of defects in material, workmanship, and mechanical function. For the lifetime of the original purchaser, SIG SAUER agrees to correct any defect in the firearm for the original purchaser by repair, adjustment, or replacement, at SIG SAUER's option, with the same or comparable quality components (or by replacing the firearm at SIG SAUER's option); provided however that a Return Merchandise Authorization (RMA) is first obtained by contacting SIG SAUER Customer Service, and the firearm is returned unloaded and freight prepaid to:

SIG SAUER  
18 Industrial Drive  
Exeter, NH 03833.

This limited warranty is null and void if the firearm has been misused, damaged (by accident or otherwise), fired with handloaded, reloaded, or improper ammunition, fired with an obstruction in the barrel, damaged through failure to provide reasonable and necessary maintenance as described in the manual accompanying the firearm, or if unauthorized repair or any alteration, including of a cosmetic nature, has been performed on the firearm. This limited warranty does not apply to normal wear and tear of any parts.

Subject to the foregoing, this limited warranty confers the right to have the covered firearm or its parts repaired, adjusted, or replaced exclusively upon the original purchaser, which right is not transferable to any other person. This warranty does not apply to any accessory items attached or appurtenant to the firearm.



ANY WARRANTIES IMPLIED BY LAW, INCLUDING ANY IMPLIED WARRANTIES OF MERCHANTABILITY OR FITNESS FOR A PARTICULAR PURPOSE, ARE EXPRESSLY DISCLAIMED. REPAIR, ALTERATION, OR REPLACEMENT AS PROVIDED HEREIN IS YOUR EXCLUSIVE REMEDY FOR ANY DEFECTIVE PRODUCT. IN NO EVENT SHALL SIG SAUER OR ANY COMPANY AFFILIATED WITH SIG SAUER BE LIABLE FOR ANY SPECIAL, INCIDENTAL, OR CONSEQUENTIAL DAMAGES OF ANY KIND ARISING OUT OF THE PURCHASE OR USE OF THIS PRODUCT, WHETHER BASED UPON CONTRACT, TORT, STATUTE, OR OTHERWISE.

Some states do not allow the exclusion or limitation of implied warranties, or the exclusion or limitation of incidental or consequential damages, so some or all of the above limitations or exclusions may not apply to you. This warranty gives you specific legal rights, and you may also have other rights which vary from State to State.

THIS WARRANTY APPLIES TO U.S. COMMERCIAL CUSTOMERS ONLY, AND DOES NOT APPLY TO GOVERNMENT, MILITARY, LAW ENFORCEMENT, OR NON-US CUSTOMERS. NON-US CUSTOMERS SHOULD CONTACT THEIR LOCAL DEALER OR DISTRIBUTOR FOR APPLICABLE WARRANTY COVERAGE.



NOTES:

NOTES:

**SIGSAUER®**

[sigsauer.com](https://sigsauer.com)

**SIG SAUER, Inc.**  
**72 Pease Boulevard, Newington, NH 03801 USA**

All trademarks, service marks, trade names, trade dress, product names and logos appearing in this manual are the property of their respective owners. No trademark or service mark appearing in this manual may be used without written consent of the mark's owner.