

SIG SAUER®

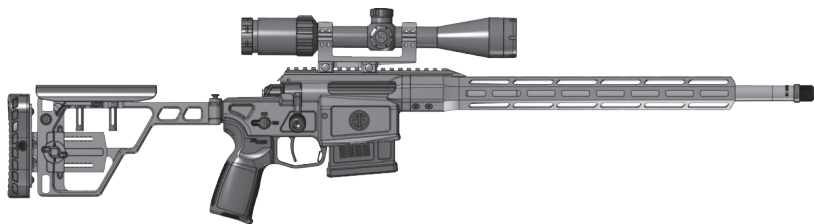

*SHOWN WITH OPTIONAL SCOPE AND MOUNT

SIG CROSS®

OPERATOR'S MANUAL: HANDLING & SAFETY INSTRUCTIONS



READ THE INSTRUCTIONS AND WARNINGS IN THIS MANUAL CAREFULLY BEFORE USING THIS FIREARM. DO NOT DISCARD THIS MANUAL.

THIS MANUAL SHOULD ALWAYS ACCOMPANY THIS FIREARM AND BE TRANSFERRED WITH IT UPON CHANGE IN OWNERSHIP, OR WHEN THE FIREARM IS PRESENTED TO ANOTHER PERSON.



WARNINGS

1.0 SAFETY WARNINGS

READ THIS ENTIRE MANUAL THOROUGHLY AND CAREFULLY PRIOR TO USING THIS FIREARM.

The warnings in this operator's manual are extremely important. By understanding the dangers inherent in the use of any firearm and by taking the precautions described in this manual, you can experience a high level of safety in the use of your firearm. Failure to heed any of these warnings may result in serious injury or death to you or others, as well as severe damage to the firearm or other property.

WARNINGS in this manual identify a clear danger to the person performing that procedure. Warnings are identified by a red banner with the word **WARNING** in white, bold, uppercase letters and a **WARNING** icon. Failure to comply with a **WARNING** can result in serious injury or death to you or a bystander.



WARNING

CAUTIONS in this manual identify a risk of damage to the firearm being maintained. **CAUTIONS** are identified by a black banner with the word **CAUTION** in white, bold, uppercase letters.

CAUTION



WARNINGS

SIG SAUER

As a valued SIG SAUER customer, we encourage you to visit sigsauer.com. There you will find links to product information and updates, merchandise promotions, and educational videos that will be of interest to you as an owner of SIG SAUER products.

SIG SAUER firearms are designed to function reliably with proper care and knowledgeable use. You must understand the safe operation and use of your SIG SAUER firearm. Read and follow these instructions carefully. Do not use the firearm unless you fully understand these instructions and the safe operation of your firearm. Failure to heed any of these instructions may result in serious injury or death to you or others, as well as severe damage to the firearm or other property.

Your firearm comes equipped with effective, well-designed safety features. However, never rely completely on any safety mechanism. Safety mechanisms are designed to augment, not replace safe handling practices. Careless and improper handling of any firearm can result in an unintentional discharge.

Only your safe firearm handling habits will ensure the safe use of your firearm. Like all mechanical devices, the safety mechanisms are subject to breakage or malfunction and can be negatively affected by wear, abuse, dirt, corrosion, incorrect assembly, improper adjustment or repair, or lack of maintenance. Moreover, there is no such thing as a safety mechanism that is “childproof” or that can completely prevent accidental discharge from improper usage, carelessness, “horseplay”, or abusive handling.

The best safety is proper and applied training in safe firearm handling. Always handle your firearm as though you expect the safeties not to work.



WARNINGS

1.0 SAFETY WARNINGS – CONTINUED

Do not load a cartridge into the chamber until you are ready to use the firearm. Keep the firearm on SAFE until you are actually ready to use the firearm. Always move the selector fully to its engaged position and visually check it. The selector is not on SAFE unless it is completely on SAFE.

ABUSIVE HANDLING

SIG SAUER firearms incorporate effective mechanical safeties. However, like any mechanical device, exposure to abusive conditions may have a negative effect on these safety mechanisms and cause them to fail to work as designed. Do not subject your SIG SAUER firearm to any type of abusive handling. This includes the firearm being dropped, impact to the firearm, or the firearm being struck by another object. Make sure you always maintain control of your firearm at all times. If your firearm does suffer an abusive event such as previously described, do not attempt to use the firearm. Keep the firearm pointed in a safe direction, unload and clear the firearm of all ammunition immediately, and have it inspected by a certified SIG SAUER armorer prior to using the firearm.

A safe direction is defined as an area in which, if the firearm were to discharge, no property damage would occur and no personal injury would result.

As previously noted, if your SIG SAUER firearm does suffer an abusive event, unload it immediately and have it inspected by a certified SIG SAUER Armorer or gunsmith prior to using the firearm.

Intentional or repetitive abusive handling of any SIG SAUER firearm will void the manufacturer's warranty and could render the firearm unsafe.



WARNINGS

SIG SAUER

REPLACEMENT PARTS

Do not attempt to disassemble your SIG SAUER firearm beyond the point explained in this manual. Disassembly beyond the instructions in this manual is restricted to a certified SIG SAUER armorer. Failure to comply with these restrictions will void your warranty.

Warnings and instructions about the use of some SIG SAUER replacement parts, assemblies, and accessories may be described in literature accompanying the specific products. Read and carefully follow those instructions. Such warnings and instructions are provided to assure the safe functioning of the firearm. Failure to heed them may result in improper functioning, damage to the firearm, and serious injury or death to you or others.

ALTERATIONS

This SIG SAUER firearm was designed to function properly in its original condition. Unauthorized alterations can make it unsafe. Do not alter any part or add or substitute any parts or accessories not manufactured by SIG SAUER for this firearm. The addition of any parts or accessories beyond the user level of maintenance described in this manual is not authorized.



WARNINGS

1.0 SAFETY WARNINGS – CONTINUED

ACCESSORIES

It is your responsibility to ensure that all accessories, such as slings and firearm-mounted lights, are compatible with this firearm and that the accessories do not interfere with the safe operation and handling of the firearm.

TRANSPORTING

When transporting your firearm, be sure the firearm is unloaded and cleared of all ammunition. It is your responsibility to familiarize yourself with the laws of any state you will be traveling through with your firearm.

STORAGE

The only safe way to store your firearm is unloaded, cleared of all ammunition, and secure. Safe and secure storage is one of your most important responsibilities. Store your unloaded firearm separate from your ammunition and in places inaccessible to children or unauthorized persons.

CHAMBER SAFETY FLAG

Every SIG SAUER firearm is shipped with a chamber safety flag. The chamber safety flag prevents the chambering of a round when installed and provides a readily visible indication that the firearm's chamber is empty. The chamber safety flag is to be installed in the firearm's chamber at all times when the firearm is not in use. Many public ranges require chamber safety flags be installed when the firing line is cold.



WARNINGS

SIG SAUER

LIABILITY

This product is classified as a FIREARM and is sold by SIG SAUER with the specific understanding that we shall not be responsible in any manner whatsoever for malfunctioning of the firearm, physical injury, or property damage resulting in whole or in part from:

- Criminal or negligent discharge
- Improper, careless, or abusive handling
- Unauthorized modifications or parts replacement
- Defective, improper, hand-loaded, or reloaded ammunition
- Corrosion
- Neglect
- Other influences beyond our direct and immediate control

This limitation applies regardless of whether liability is asserted on the basis of contract, negligence, or strict liability (including any failure to warn). Under no circumstance shall SIG SAUER, Inc. be liable for incidental or consequential damages such as loss of use of property, commercial loss, and loss of earnings or profits.



WARNINGS

BASIC RULES OF SAFE FIREARMS HANDLING

1. ALWAYS treat every firearm as if it were loaded.
2. ALWAYS be sure the barrel is clear of any obstruction.
3. ALWAYS be sure of your backstop, what lies beyond, and the safety of bystanders before you shoot.
4. ALWAYS use clean, dry, original factory-made ammunition of the proper type and caliber for your firearm.
5. ALWAYS wear ear protection and safety glasses when shooting.
6. ALWAYS carry your firearm so that you can control the direction of the muzzle if you fall or stumble.
7. NEVER shoot at a flat surface or water.
8. DO NOT leave a loaded firearm unattended. Firearms and ammunition should be stored separately, locked if possible, and beyond the reach of children, careless adults, or unauthorized users.
9. NEVER allow your firearm to be used by anyone who has not read and understood this operator's manual.
10. DO NOT point any firearm, loaded or unloaded, at any undesired or unsafe target.
11. NEVER discharge your firearm near an animal unless the animal is trained to accept the noise. An animal's startled reaction could injure it or cause an accident.
12. NEVER drink alcoholic beverages or use drugs before or during shooting, as your vision and judgment could be seriously impaired, making your firearm handling unsafe.



WARNINGS

SIG SAUER

1.1 EYE AND EAR PROTECTION



Always wear safety glasses that meet the requirements of American National Standards Institute (ANSI) z87.1 and ear plugs and “ earmuff ”-type protectors whenever you are shooting. Always make certain that persons close to you are similarly protected. Unprotected eyes may be injured by powder, gas, carbon residue, lubricant, metallic particles, or similar debris that may emanate occasionally from any firearm in normal use. Without ear protection, repeated exposure to shooting noise may lead to cumulative, permanent hearing loss.

1.2 AMMUNITION

Use only high-quality, original, factory-manufactured ammunition. Do not use cartridges that are dirty, wet, corroded, bent, or damaged. Do not oil cartridges. Do not spray aerosol-type lubricants, preservative, or cleaners directly onto cartridges or where excess spray may flow into contact with cartridges. Lubricant or other foreign matter on cartridges can cause potentially dangerous ammunition malfunctions. Use only ammunition of the caliber for which your firearm is chambered. The proper caliber is permanently engraved on your firearm; never attempt to use ammunition of any other caliber.

The use of reloaded, “re-manufactured” hand-loaded, or other nonstandard ammunition voids all warranties. Reloading is a science and improperly loaded ammunition can be extremely dangerous.



WARNINGS

1.2 AMMUNITION – CONTINUED

Severe damage to the firearm and serious injury or death to the shooter or to others may result. Always use ammunition that complies with the industry performance standards established by the Sporting Arms and Ammunition Manufacturers' Institute, Inc. (SAAMI) or ammunition manufactured to U.S. military specifications.

SIG SAUER, Inc. specifically disclaims responsibility for any damage or injury whatsoever occurring in connection with or as a result of the use in any SIG SAUER firearm of faulty, nonstandard, "re-manufactured" hand-loaded (reloaded) ammunition, or cartridges other than those for which the firearm was originally chambered.

Firearms may be severely damaged and serious injury or death to the shooter or to others may result from any condition causing excessive pressure inside the chamber or barrel during firing. Excessive pressure can be caused by obstructions in the barrel, propellant powder overloads, the use of incorrect cartridges, or defectively assembled cartridges. In addition, the use of a dirty, corroded, or damaged cartridge can lead to a burst cartridge case and consequent damage to the firearm and personal injury from the sudden escape of high-pressure propellant gas within the firearm's mechanism.

OBSTRUCTED BORE

Immediately stop shooting, keep the firearm pointed in a safe direction whenever:

- You have difficulty in or feel unusual resistance in chambering a cartridge;
- A cartridge misfires (does not go off);
- The mechanism fails to extract a fired cartridge case;
- Unburned grains of propellant powder are discovered spilled in the mechanism;
- A shot sounds weak or abnormal. It is possible that a bullet is lodged part way down the barrel.



WARNINGS

SIG SAUER

Firing a subsequent bullet into the obstructed barrel can damage the firearm and cause serious injury to the shooter or to bystanders.

Bullets can become lodged in the barrel when:

- The cartridge has been improperly loaded without propellant powder or the powder fails to ignite (ignition of the cartridge primer alone will push the bullet out of the cartridge case, but usually does not generate sufficient energy to expel the bullet completely from the barrel);
- The bullet is not properly seated in the cartridge case. When such a cartridge is extracted from the chamber without being fired, the bullet may be left behind in the bore at the point where the rifling begins. Subsequent chambering of another cartridge may push the first bullet further into the bore.

If there is any reason to suspect that a bullet is obstructing the barrel, immediately unload and clear the firearm. Field strip the firearm and look through the bore of the barrel. It is not sufficient to merely look in the chamber. A bullet may be lodged some distance down the barrel where it cannot easily be seen.

If a bullet is in the bore, do not attempt to shoot it out by using another cartridge or by blowing it out with a blank or a cartridge from which the bullet has been removed. Such techniques can generate excessive pressure, damage the firearm, and cause serious personal injury or death.

If the bullet can be removed by tapping it with a cleaning rod, clean any unburned powder grains from the bore, chamber, and mechanism before resuming shooting. If the bullet cannot be dislodged by tapping it with a cleaning rod, take the firearm to a certified SIG SAUER Armorer.



WARNINGS

1.2 AMMUNITION – CONTINUED

Dirt, corrosion, or other foreign matter on a cartridge can impede chambering and may cause the cartridge case to burst upon firing. A damaged or deformed cartridge may also impede chambering or cause the cartridge case to burst upon firing.

Do not lubricate cartridges. Be sure to wipe the chamber clean of any oil or preservative before shooting. Oil interferes with the friction between cartridge case and chamber wall that is necessary for safe functioning and subjects the firearm to stress similar to that imposed by excessive pressure.

Use lubricants sparingly on the moving parts of your firearm. Avoid excessive spraying of any aerosol gun care product, especially where it might get on ammunition. All lubricants, aerosol spray lubricants in particular, can penetrate cartridge primers and cause misfires. Some highly penetrative lubricants can also migrate inside cartridge cases and cause deterioration of the propellant powder; on firing, the powder might not ignite. If only the primer ignites, there is danger that the bullet may become lodged in the barrel.

Death, serious injury, and damage to the firearm can result from the use of wrong ammunition, bore obstructions, powder overloads, or incorrect cartridge components. Always wear shooting glasses and hearing protection.



WARNINGS

SIG SAUER



WARNING: CANCER AND REPRODUCTIVE HARM—www.P65warnings.ca.gov



DISCHARGING FIREARMS IN POORLY VENTILATED AREAS, CLEANING FIREARMS, OR HANDLING AMMUNITION MAY RESULT IN EXPOSURE TO LEAD AND OTHER SUBSTANCES KNOWN TO THE STATE OF CALIFORNIA TO CAUSE BIRTH DEFECTS, REPRODUCTIVE HARM, AND OTHER SERIOUS PHYSICAL INJURY. MAINTAIN ADEQUATE VENTILATION AT ALL TIMES. WASH HANDS THOROUGHLY AFTER EXPOSURE. SHOOTING OR CLEANING FIREARMS MAY EXPOSE YOU TO LEAD.



WARNINGS

1.3 STATE-BY-STATE WARNINGS

Certain states require, by law, that their own specified warning notices, in larger than-normal type be conspicuously included by the manufacturer, distributor, or retail dealer with firearms sold in that state. SIG SAUER sells its products in compliance with applicable laws and regulations. Because our products may be sold in these states, we include the following:



CALIFORNIA: WARNING

Firearms must be handled responsibly and securely stored to prevent access by children and other unauthorized users. California has strict laws pertaining to firearms, and you may be fined or imprisoned if you fail to comply with them. Visit the Web site of the California Attorney General at <https://oag.ca.gov/firearms> for information on firearm laws applicable to you and how you can comply. Prevent child access by always keeping guns locked away and unloaded when not in use. If you keep a loaded firearm where a child obtains and improperly uses it, you may be fined or sent to prison."

If you or someone you know is contemplating suicide, please call the National Suicide Prevention Lifeline at 1-800-273 TALK (8255).



ADVERTENCIA

Las armas de fuego deben manipularse de manera responsable y segura para evitar el acceso de niños y otros usuarios no autorizados. California tiene leyes estrictas relacionadas con armas de fuego, y usted puede ser multado o encarcelado si no las cumple. Visite el sitio web del fiscal general de California en <https://oag.ca.gov/firearms> para obtener información sobre las leyes de armas de fuego que son aplicables y cómo puede cumplirlas. Evite el acceso de niños manteniendo siempre las armas bloqueadas y descargadas cuando no estén en uso. Si mantiene un arma de fuego cargada donde un niño la puede obtener y la usa indebidamente, se le puede multar o enviar a prisión.

Si usted o alguien que conoce está contemplando el suicidio, llame a la Línea Nacional de Prevención del Suicidio al 1-800-273 TALK (8255).



WARNINGS

SIG SAUER

CONNECTICUT:

"UNLAWFUL STORAGE OF A LOADED FIREARM MAY RESULT IN IMPRISONMENT OR FINE."

FLORIDA:

"IT IS UNLAWFUL, AND PUNISHABLE BY IMPRISONMENT AND FINE, FOR ANY ADULT TO STORE OR LEAVE A FIREARM IN ANY PLACE WITHIN THE REACH OR EASY ACCESS OF A MINOR UNDER 18 YEARS OF AGE OR TO KNOWINGLY SELL OR OTHERWISE TRANSFER OWNERSHIP OR POSSESSION OF A FIREARM TO A MINOR OR A PERSON OF UNSOUND MIND."

MAINE:

"ENDANGERING THE WELFARE OF A CHILD IS A CRIME. IF YOU LEAVE A FIREARM AND AMMUNITION WITHIN EASY ACCESS OF A CHILD, YOU MAY BE SUBJECT TO FINE, IMPRISONMENT OR BOTH. KEEP FIREARMS AND AMMUNITION SEPARATE. KEEP FIREARMS AND AMMUNITION LOCKED UP. USE TRIGGER LOCKS."

MARYLAND:

"WARNING: CHILDREN CAN OPERATE FIREARMS WHICH MAY CAUSE DEATH OR SERIOUS INJURY. IT IS A CRIME TO STORE OR LEAVE A LOADED FIREARM IN ANY LOCATION WHERE AN INDIVIDUAL KNEW OR SHOULD HAVE KNOWN THAT AN UNSUPERVISED MINOR WOULD GAIN ACCESS TO THE FIREARM. STORE YOUR FIREARM RESPONSIBLY!"



WARNINGS

MASSACHUSETTS:

“WARNING FROM THE MASSACHUSETTS ATTORNEY GENERAL: This handgun is not equipped with a device that fully blocks use by unauthorized users. More than 200,000 firearms like this one are stolen from their owners every year in the United States. In addition, there are more than a thousand suicides each year by younger children and teenagers who get access to firearms. Hundreds more die from accidental discharge. It is likely that many more children sustain serious wounds, or inflict such wounds accidentally on others. In order to limit the chance of such misuse, it is imperative that you keep this weapon locked in a secure place and take other steps necessary to limit the possibility of theft or accident. Failure to take reasonable preventative steps may result in innocent lives being lost, and in some circumstances may result in your liability for these deaths.”



WARNINGS

SIG SAUER

MASSACHUSETTS: - Continued

“IT IS UNLAWFUL TO STORE OR KEEP A FIREARM, PISTOL, SHOTGUN OR MACHINE GUN IN ANY PLACE UNLESS THAT WEAPON IS EQUIPPED WITH A TAMPER RESISTANT SAFETY DEVICE OR IS STORED OR KEPT IN A SECURELY LOCKED CONTAINER.”

NEW JERSEY:

“IT IS A CRIMINAL OFFENSE TO LEAVE A LOADED FIREARM WITHIN EASY ACCESS OF A MINOR.”

NEW YORK CITY, NY:

“THE USE OF A LOCKING DEVICE OR SAFETY LOCK IS ONLY ONE ASPECT OF RESPONSIBLE FIREARMS STORAGE. FOR INCREASED SAFETY, FIREARMS SHOULD BE STORED UNLOADED AND LOCKED IN A LOCATION THAT IS BOTH SEPARATE FROM THEIR AMMUNITION AND INACCESSIBLE TO CHILDREN AND OTHER UNAUTHORIZED PERSONS.”



WARNINGS

NORTH CAROLINA:

Any person who resides in the same premises as a minor, owns or possesses a firearm, and stores or leaves the firearm (i) in a condition that the firearm can be discharged and (ii) in a manner that the person knew or should have known that an unsupervised minor would be able to gain access to the firearm, is guilty of a Class 1 misdemeanor if a minor gains access to the firearm without the lawful permission of the minor's parents or a person having charge of the minor and the minor:

- (1) Possesses it in violation of G.S. 14-269.2(b)
- (2) Exhibits it in a public place in a careless, angry, or threatening manner;
- (3) Causes personal injury or death with it not in self defense; or
- (4) Uses it in the commission of a crime.

TEXAS:

"IT IS UNLAWFUL TO STORE, TRANSPORT, OR ABANDON AN UNSECURED FIREARM IN A PLACE WHERE CHILDREN ARE LIKELY TO BE AND CAN OBTAIN ACCESS TO THE FIREARM."

WISCONSIN:

"IF YOU LEAVE A LOADED FIREARM WITHIN THE REACH OR EASY ACCESS OF A CHILD YOU MAY BE FINED OR IMPRISONED OR BOTH IF THE CHILD IMPROPERLY DISCHARGES, POSSESSES, OR EXHIBITS THE FIREARM."

Please check with your licensed retailer, state police, or local police for additional warnings, which may be required by local law or regulation. Such regulations change constantly, and local authorities are in the best position to advise you on such legal matters.



WARNINGS

SIG SAUER

1.4 LOCKING DEVICES



All firearms are originally shipped with a key-operated locking device, except for Custom Works firearms that are shipped with a lockable case.

Although it can help provide secure storage for your unloaded firearm, any locking device can fail.

All firearms are designed to fire if they are loaded and the trigger is pressed.

Therefore, never install the locking device inside the trigger guard or in any way that makes it possible to press the trigger!

Do not leave the keys in the lock.

The ultimate responsibility for secure storage of any firearm must depend upon its owner and his or her individual circumstances.

Firearms should be stored unloaded, in a secure location, separate from their ammunition.

To maximize effectiveness and reduce the chances of malfunction or damage to a firearm, ALWAYS refer to the locking device's manufacturer directions for installation and removal of the device.



WARNINGS

1.5 SAFETY INFORMATION

This operator's manual is designed to assist you in learning how to use and care for your SIG SAUER® firearm properly.

Only when you are certain that you fully understand this manual and can properly carry out its instructions should you practice loading and firing your firearm with live ammunition. Having a firearm in your possession is a full-time job; you cannot guess and you cannot forget. You must know how to use your firearm safely.

If you have any doubts about your ability to handle or use this firearm safely, you should seek supervised instruction.

The SIG SAUER Academy provides all levels of firearms safety and skill training, from beginner to expert.

For more information, contact:

SIG SAUER[®]
ACADEMY

sigsaueracademy.com • (603) 610-3400
Epping, New Hampshire

SAFETY MUST BE THE FIRST AND CONSTANT CONSIDERATION OF EVERY PERSON WHO HANDLES FIREARMS AND AMMUNITION.

For more information about safety, responsible firearms ownership, and shooting sports, contact:
National Rifle Association (NRA) of America
11250 Waples Mill Road, Fairfax, VA 22030-7400 • 1-800-672-3888
nra.com

PAGE INTENTIONALLY LEFT BLANK



Contents

| | |
|------------------------------------------------------------|----|
| 1.0 Safety Warnings | 2 |
| 1.1 Eye And Ear Protection. | 9 |
| 1.2 Ammunition. | 9 |
| 1.3 State-By-State Warnings | 14 |
| 1.4 Locking Devices | 19 |
| 1.5 Safety Information | 20 |
| 2.0 Mechanical Characteristics and Rifle Theory | 24 |
| 2.1 Rifle Description | 24 |
| 2.2 Controls and Features | 26 |
| 2.3 Groups and Assemblies | 30 |
| 2.4 Cycle of Operation | 36 |
| 3.0 Operating the SIG CROSS Firearm | 38 |
| 3.1 Preparation before using the firearm. | 38 |
| 3.2 Selector Operation | 39 |
| 3.3 Unload and Clear the SIG CROSS. | 40 |
| 3.4 Loading/Reloading | 42 |
| 3.5 Firing the SIG CROSS | 45 |
| 3.6 Adverse/Special Conditions | 46 |
| 3.7 Operating/Adjusting Stock Assembly. | 48 |
| 3.8 Adjusting Trigger | 60 |
| 4.0 User-Level Authorized Preventive Maintenance | 62 |
| 4.1 Field Strip the SIG CROSS. | 62 |
| 4.2 Disassemble Magazine. | 68 |
| 5.0 Cleaning and Lubrication. | 70 |
| 5.1 Cleaning the Bore and Chamber. | 70 |

| | | |
|------|------------------------------------------------------|-----|
| 5.2 | Cleaning the Bolt Assembly | 72 |
| 5.3 | Cleaning Receiver and Exterior of Firearm. | 74 |
| 5.4 | Cleaning Magazine. | 74 |
| 5.5 | Lubricating Bolt Assembly | 74 |
| 5.6 | Lubricate Receiver and Exterior of Firearm | 76 |
| 6.0 | Reassembly | 77 |
| 6.1 | Reassemble Bolt Assembly | 77 |
| 6.2 | Install Bolt Assembly | 83 |
| 6.3 | Reassemble Magazine. | 84 |
| 6.4 | Function Check. | 85 |
| 6.5 | Troubleshooting | 86 |
| 6.6 | CROSS Rifle Parts Diagram | 88 |
| 6.7 | Bolt Assembly Parts Diagram | 90 |
| 7.0 | Optional Configurations | 92 |
| 7.1 | Changing Receiver Top Rail | 92 |
| 7.2 | Changing Bolt Knob | 93 |
| 7.3 | Changing the Barrel | 94 |
| 8.0 | Transportation and Storage | 103 |
| 9.0 | Replacement Parts Policy | 105 |
| 10.0 | Factory repair of your firearm | 107 |
| 10.1 | Returning firearms for repair | 108 |
| | SIG SAUER® Infinite Guarantee® | 114 |



2.0 MECHANICAL CHARACTERISTICS AND RIFLE THEORY

2.1 RIFLE DESCRIPTION

GENERAL

The SIG CROSS is a magazine fed, bolt action, precision rifle available in 6.5 Creedmoor, 277 SIG Fury, and 308 Winchester. The rifle features a folding stock that is adjustable for length of pull (LOP), comb height, buttpad height, buttpad angle, and stock folding direction. The trigger pull can be adjusted by the operator over an adjustment range of approximately 1 1/2 pounds.

Scan the QR code to visit sigsauer.com where you will find additional information about SIG SAUER products, SIG SAUER Academy and the SIG Experience Center, Special Programs, and additional support.



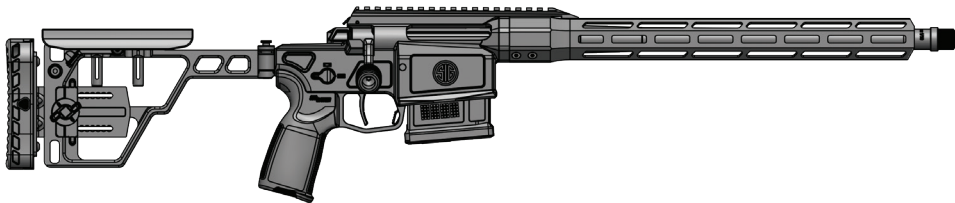



2.2 CONTROLS AND FEATURES

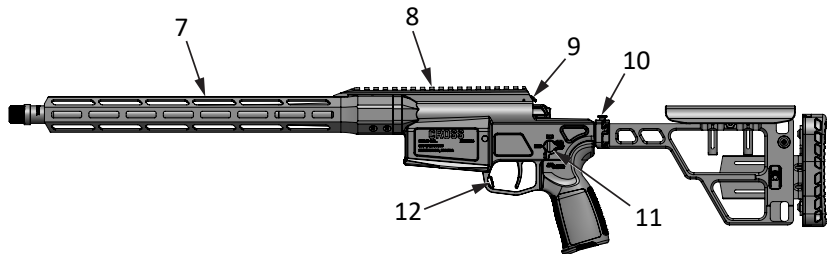
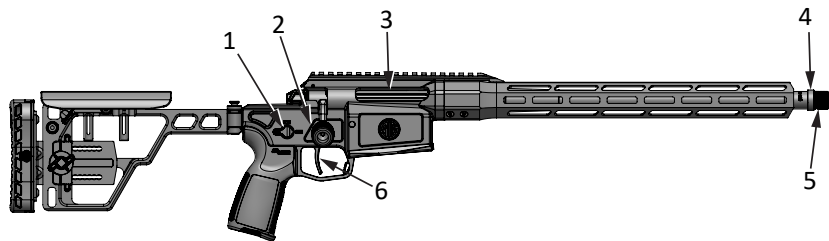

| NUMBER | NOMENCLATURE |
|---------------|------------------------------|
| 1 | Ambidextrous Safety Selector |
| 2 | Bolt Knob |
| 3 | Ejection Port |
| 4 | Taper Cap |
| 5 | Thread Protector |
| 6 | Trigger |
| 7 | Handguard |
| 8 | MIL-STD 1913 Rail |
| 9 | Bolt Catch |
| 10 | Stock Lock Button |
| 11 | Ambidextrous Safety Selector |
| 12 | Magazine Release |



2.2.1 CONTROLS AND FEATURES – STOCK

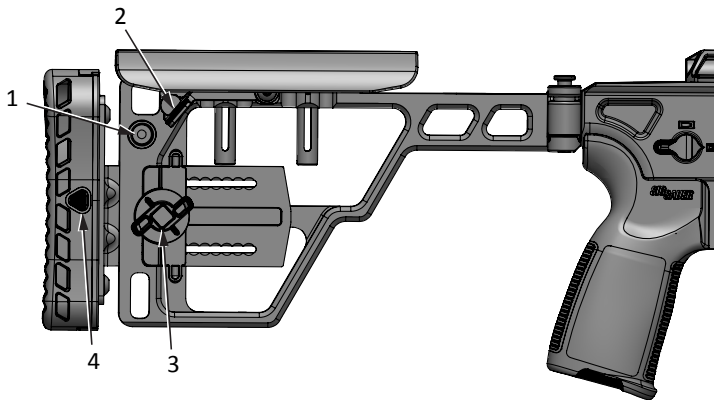

| NUMBER | NOMENCLATURE |
|---------------|------------------------|
| 1 | Quick Detach Sling Cup |
| 2 | Comb Clamp Lever |
| 3 | Length of Pull Knob |
| 4 | Buttpad Button |



2.3 GROUPS AND ASSEMBLIES

2.3.1 BOLT ASSEMBLY

The bolt assembly consists of the bolt head assembly, bolt carrier, bolt handle with knob, and striker assembly.

The CROSS ships with the small bolt knob as standard equipment. A large knob is available as an accessory.

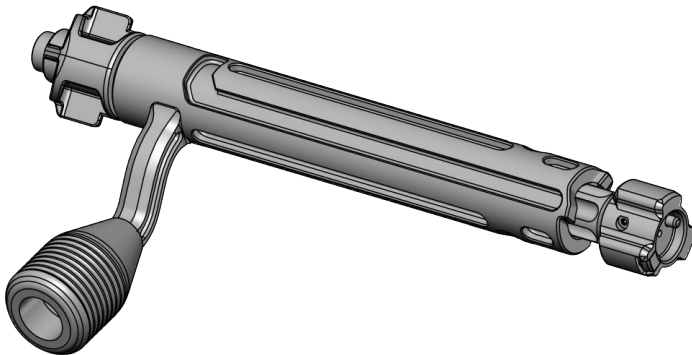

A. Bolt Head Assembly

The bolt head assembly locks the chamber during firing and includes the bolt head, extractor, ejector, and locking lugs.

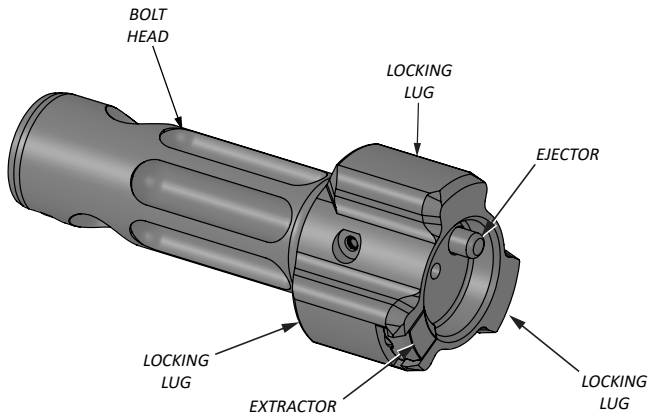



B. Bolt Carrier

The bolt carrier houses the bolt head assembly, striker assembly, bolt head pin, and bolt handle.

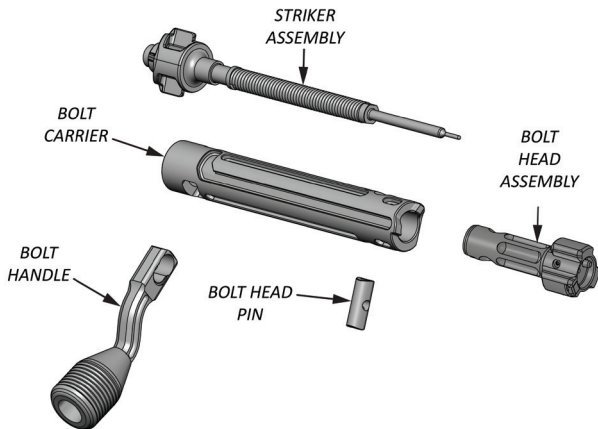

2.3.2 RECEIVER ASSEMBLY

The receiver assembly houses the fire control components including the trigger, ambidextrous safety selector, the bolt catch, receiver top rail, ejection port, magazine well, magazine release, and grip.

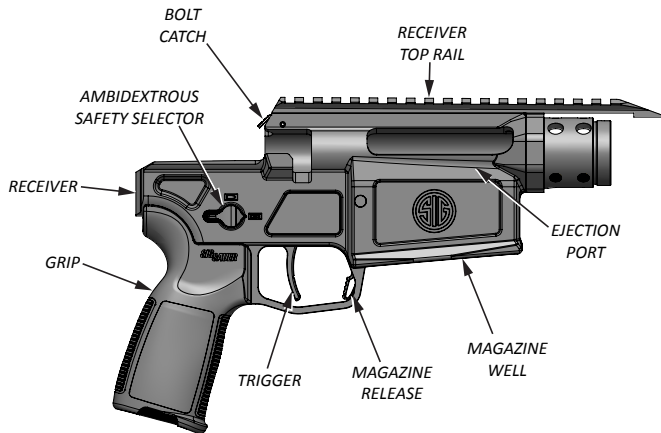



2.3.3 HANDGUARD AND BARREL ASSEMBLY

The handguard features multiple M-LOK® attachment points. The barrel assembly includes the barrel extension, barrel nut, barrel jam nut, barrel, taper cap, and thread protector.

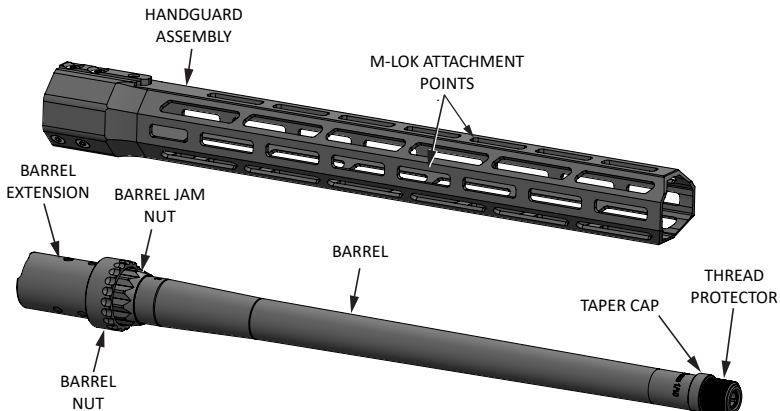

2.3.4 STOCK ASSEMBLY

The stock assembly features the comb assembly, stock lock button, comb clamp lever, length of pull knob, QD sling point, buttpad, and buttpad button.

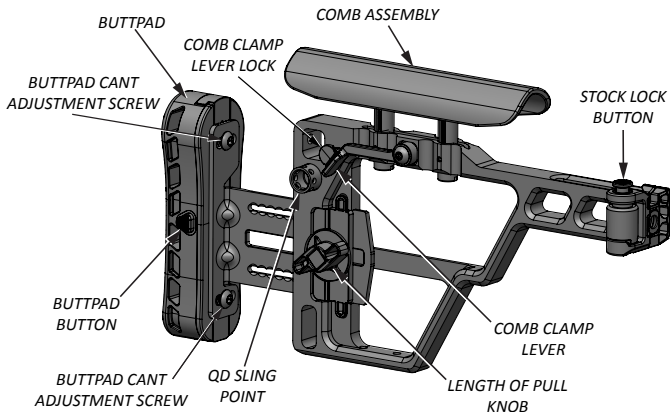



2.4 CYCLE OF OPERATION

There are eight steps in the cycle of operation of the SIG CROSS firearm.

COCKING

Primary cocking takes place as the bolt handle is raised. A cam at the rear of the rotating bolt carrier forces the striker assembly rearward, compressing the main spring. A notch at the rear of the bolt carrier holds the striker assembly in the cocked position until the bolt handle is pushed downward during the locking function.

FEEDING

Feeding begins with the bolt in its rearmost position and a loaded magazine inserted into the magazine well. As the user pushes the bolt forward, the cartridge is guided by the magazine feed lips and the feed ramp so that the cartridge is directed into the chamber.

CHAMBERING

As the user continues to push the bolt forward, the cartridge is pushed clear of the magazine feed lips. The forward travel of the bolt pushes the cartridge the rest of the way into the chamber.

LOCKING

Rotating the bolt handle downward causes the locking lugs on the bolt head to engage the lugs of the barrel extension. The cartridge head is now seated in the bolt head assembly, compressing the ejector while the extractor engages the rim of the cartridge.

The sear engages and locks the striker assembly in the cocked position. The CROSS firearm is now ready for firing.

FIRING

With the bolt locked and the safety selector lever disengaged, the CROSS can be fired by pressing the trigger. Pressing the trigger rearward rotates the trigger bar releasing the sear. The sear is cammed down by pressure from the main spring loaded striker assembly. The striker assembly is driven forward under spring tension to strike the primer of the cartridge loaded in the chamber, firing the cartridge.

UNLOCKING

Raising the bolt handle unseats the locking lugs on the bolt head from the lugs in the barrel extension, allowing the bolt to be pulled to the rear. Primary extraction occurs simultaneously with unlocking.

EXTRACTION

This operation consists of two functions.

1. Primary Extraction. Primary extraction occurs simultaneously with unlocking. The rim of the cartridge case is gripped by the extractor. During the final upward rotation of the bolt handle, the primary extraction cam partially retracts the bolt assembly completing the primary function of extraction.
2. Secondary Extraction. The bolt lugs are now free of the lugs in the barrel extension and the bolt can now be pulled to the rear, completing the secondary function of extraction.

EJECTION

The spring-loaded ejector is applying constant pressure to the left side of the cartridge head. As the bolt is pulled to the rear, the front edge of the cartridge reaches the ejection port on the right side of the receiver. Pressure exerted by the ejector, and the pulling effect of the extractor on the right side of the cartridge case head, causes the cartridge to be rotated and ejected out through the port. Rearward movement of the bolt is halted by the bolt catch.



3.0 OPERATING THE SIG CROSS FIREARM

3.1 PREPARATION BEFORE USING THE FIREARM.

Ensure you have read, understand, and are capable of following all the safety warnings on pages 2-14 of this manual in addition to the safety rules, regulations, procedures, or guidelines of your club or local shooting range.

Prior to using the firearm, it is strongly suggested to field strip the firearm (Section 4.1) and clean any fouling that might have occurred during factory testing (Section 5.0). Inspect, lubricate, and re-assemble the firearm (Section 6.0). Upon re-assembly and prior to firing the rifle, conduct the Function Check (Section 6.4). If the rifle does not complete the function check as described, call customer service (See Section 10.0).

Any maintenance beyond the user level described in this manual is to be performed by a certified SIG SAUER Armorer specifically trained on the maintenance of the CROSS rifle.

3.1.1 PREPARING THE SIG CROSS FOR USE

The SIG CROSS firearm is packaged from the factory with the bolt assembly removed. Install the bolt assembly following the steps outlined in Section 6.2 of this manual.

3.2 SELECTOR OPERATION

The SIG CROSS features an ambidextrous safety selector lever. Rotating either safety selector lever 90 degrees changes the firing mode from SAFE to FIRE. Moving one lever automatically moves the opposite lever to the same position.



SAFE



FIRE



3.3 UNLOAD AND CLEAR THE SIG CROSS

1. Ensure that the muzzle of the rifle is pointed in a safe direction at all times while unloading and clearing the firearm.
2. Remove the magazine from the rifle by pressing the magazine release and simultaneously pulling the magazine free.



3. Lift the bolt handle and pull the bolt assembly to the rear.
4. Visually and physically inspect the chamber for live rounds or spent cartridges present.



5. If you're passing the firearm to another person, allow that person to inspect the chamber prior to relinquishing the firearm. Pass the firearm with the bolt to the rear and the safety selector lever on SAFE.



3.4 LOADING/RELOADING

3.4.1 LOADING THE MAGAZINE

1. Insert the first round into the magazine angled down so the rim of the cartridge slides under the feed lips and push it to the rear.

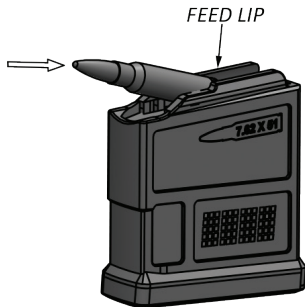

2. Load the next round using the rim of the cartridge to depress the preceding round and push to the rear underneath the feed lips. Repeat this until the magazine is full.

3.4.2 LOADING THE SIG CROSS

1. Ensure the safety selector lever is on SAFE and the muzzle is pointed in safe direction.
2. Lift the bolt handle to its upright position and pull the bolt assembly completely to the rear.
3. Insert a loaded magazine into the receiver until it engages, and is held by, the magazine catch. Always pull down on the magazine to ensure it is locked in place.

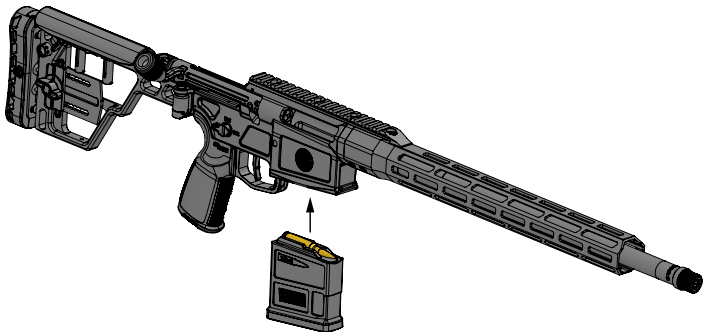



4. Push the bolt assembly completely forward and rotate the bolt handle down to its locked position.

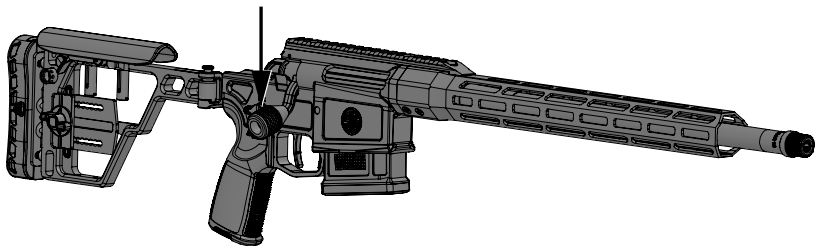

WARNING LOADED RIFLE



THE RIFLE IS NOW LOADED AND READY TO FIRE

3.4.3 RELOADING (EXPENDED MAGAZINE, CHAMBER EMPTY)

1. Rotate the safety selector lever to SAFE.
2. Press the magazine release to remove the magazine from the magazine well.
3. Repeat steps 2 through 4 from section “3.4.2 Loading the SIG CROSS”.

3.4.4 RELOADING (MAGAZINE EXPENDED/PARTIALLY EXPENDED, LIVE ROUND CHAMBERED)

1. Rotate the safety selector lever to SAFE.
2. Press the magazine release to remove the magazine from the magazine well.
3. Insert a loaded magazine until it engages, and is held by, the magazine release. Always pull down on the magazine to ensure that it is seated properly.

3.5 FIRING THE SIG CROSS

1. Unfold the stock if not already done.
2. Follow steps 1 through 4 from section “3.4.2 Loading the SIG CROSS”.
3. Face the target and point the muzzle downrange.
4. Rotate the safety selector lever from SAFE to FIRE.
5. Press the trigger to fire the rifle.



3.6 ADVERSE/SPECIAL CONDITIONS

Arctic (Extreme Cold/Sub Freezing)

- When exposed to subfreezing temperatures, thoroughly remove all existing lubricants and only apply lubricant that is designed to be used in temperatures of -65F or below. Do not use CLP as it may freeze and prevent the rifle from firing.
- Avoid bringing the firearm into heated shelters or buildings as this can cause condensation to form on moving parts, which may freeze when the firearm is brought back outdoors.
- If it is necessary for you to bring the firearm indoors allow it to warm to room temperature and then disassemble and clean it thoroughly to ensure that all moisture is removed from the firearm. Re-lubricate the firearm with the proper cold weather lubricant.
- When operating in snowy environments conduct frequent inspections of the firearm to ensure that snow has not gotten into operating parts. Work the action to ensure that it is not frozen. Use muzzle covers if available.
- If the bolt carrier becomes frozen with snow/moisture, warm the firearm using body heat or bring it indoors until free movement is restored, and then clean and re-lubricate the firearm.

Desert (Hot/Dry)

- Apply light lubrication to internal metal-on-metal moving parts only. If available, use dry graphite lubricant.
- Increase frequency of inspection and cleaning of firearm due to blowing dust and sand. Pay particular attention to the bolt assembly ensuring the striker is free of any foreign matter to include sand, dust, or mud.
- Use muzzle covers if available.
- Unload and clean ammunition and inside of magazines daily. Do not lubricate magazine.
- Cover the firearm when not in use.

Jungle (Hot/Humid)

- Increase the frequency of inspection and cleaning of the firearm to prevent corrosion.
- Apply a thin coat of lubricant on steel parts frequently.
- Inspect hidden surfaces of bolt, receiver, chamber, and barrel extension (locking lugs) for corrosion.
- Unload the magazine, clean ammunition, and inspect the inside of magazines daily for corrosion.
- Wipe ammunition dry before reloading the magazine.



3.7 OPERATING/ADJUSTING STOCK ASSEMBLY



WARNING UNLOAD/CLEAR



PRIOR TO MAKING ANY ADJUSTMENTS TO THE CROSS RIFLE ENSURE THAT THE FIREARM IS UNLOADED AND CLEARED OF ANY AMMUNITION AND ON SAFE WITH THE BOLT REARWARD. FAILURE TO COMPLY COULD RESULT IN DEATH OR SERIOUS INJURY.

3.7.1 FOLDING / UNFOLDING THE STOCK

1. Bolt must be forward to fold or unfold the stock.
2. To fold, press stock lock button while lifting the stock up and out of its latch, then rotate stock to the folded position.
3. To unfold, press the stock lock button and rotate stock out until it locks in position.

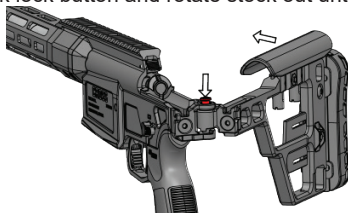

3.7.2 ADJUSTING COMB HEIGHT

1. Assume a shooting position behind the firearm.
2. Press the comb clamp lock and swing the comb clamp lever down.
3. Adjust comb to desired height and hold in place with cheek while swinging the comb clamp lever up until it is captured by the comb clamp lock.

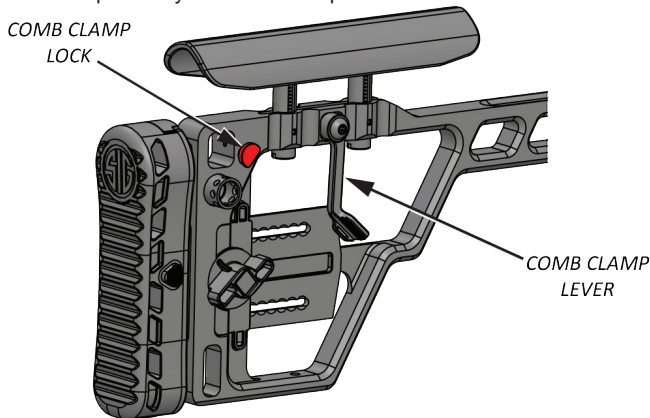



3.7.3 ADJUSTING LENGTH OF PULL

1. Loosen the length of pull knob by rotating counterclockwise several complete turns.
2. Adjust buttpad to desired position.
3. Tighten length of pull knob by rotating clockwise until tight by hand only. Do not use tools to tighten knob as damage to stock may occur.

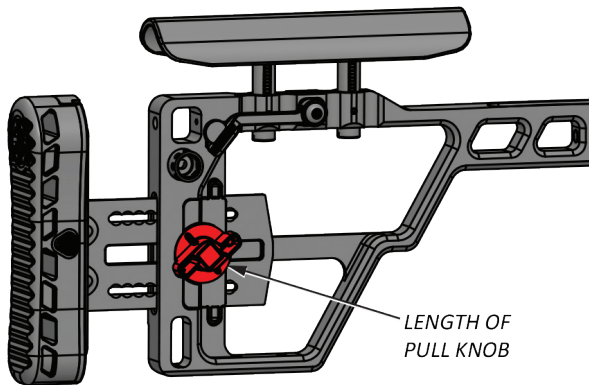

3.7.4 ADJUSTING BUTTPAD HEIGHT

1. Press and hold buttpad button.
2. Adjust buttpad height to desired position, then release buttpad button.
3. Ensure the button engages the locking recess when released and the buttpad will not move vertically.

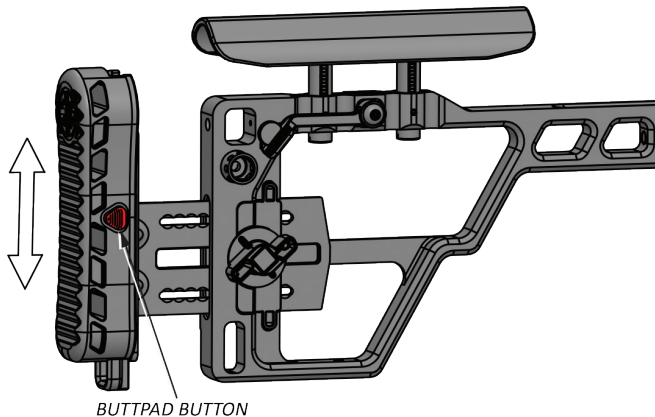



3.7.5 ADJUSTING BUTTPAD CANT

1. Use a T25 bit to loosen the two buttpad cant screws.
2. Rotate buttpad to the desired angle and ensure the positioning tabs on the buttpad are aligned in the grooves on the mating surface.
3. Tighten both buttpad cant screws to 12.5 in-lb.

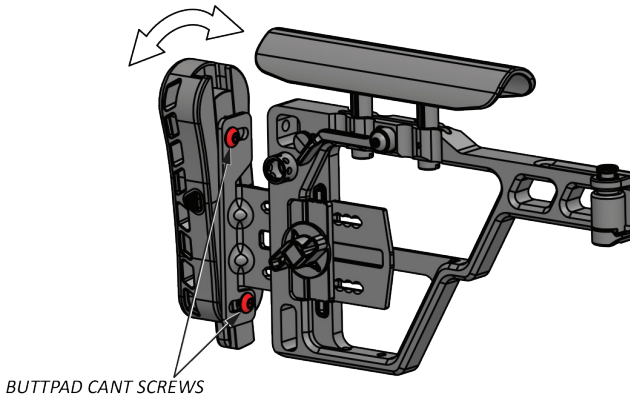

3.7.6 REVERSING COMB

NOTE

The comb spring retaining plugs keep the comb springs from blocking the installation of comb retaining pins. Do not remove the plugs when reversing comb.

1. Raise comb to gain access to comb retaining pins.
2. Push out both comb retaining pins with a 1/16 inch pin punch. Comb spring retaining plugs will retain springs in shafts.

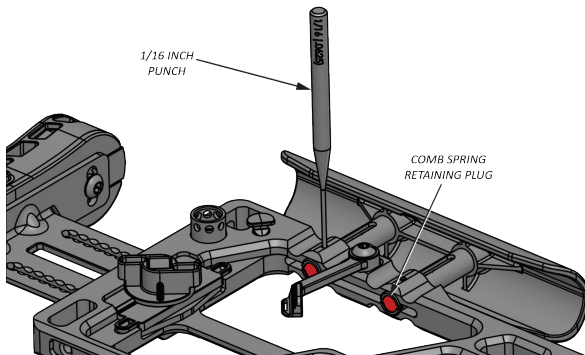



3. Reverse comb so the cheek contact surface is on the opposite side.
4. Ensure the shafts of the comb assembly are aligned so the holes for the comb retaining pins are aligned with their corresponding holes in the stock frame. The comb spring retaining plugs will keep the comb springs above the pin holes.

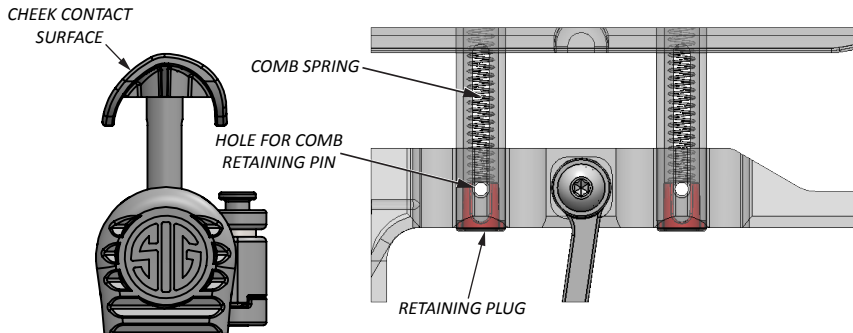

STOCK FRAME AND COMB ASSEMBLY SHOWN TRANSPARENT FOR CLARITY

5. Install the comb retaining pins in the same direction as they were removed.

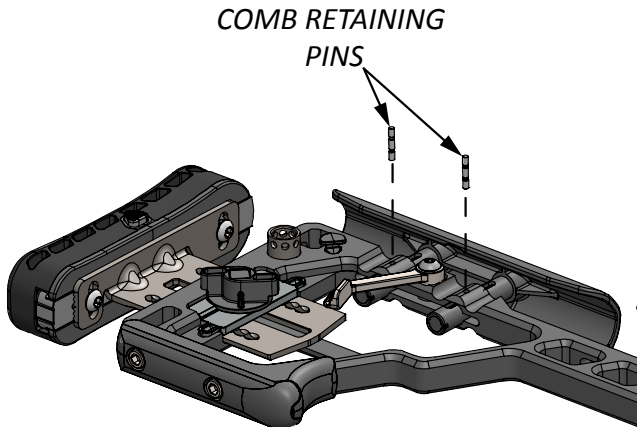



3.7.7 REVERSING QUICK DETACH SLING POINT

1. Use a T25® bit to remove the sling point retaining screw, washer and QD sling cup.
2. Reverse components and re-install on opposite side of the stock.
3. Tighten retaining screw to 35 in-lb.

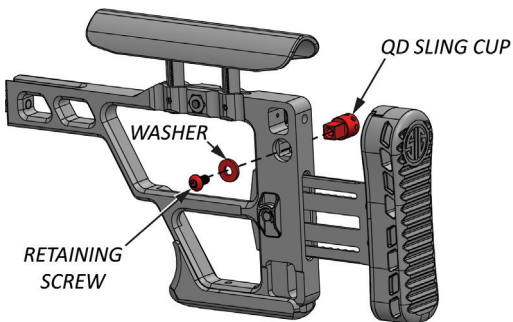

3.7.8 REVERSING STOCK FOLD DIRECTION

1. Fold stock. See section “3.7.1 Folding / Unfolding the Stock” on page 48.
2. Use a T30® bit to remove stock screw and stock assembly.

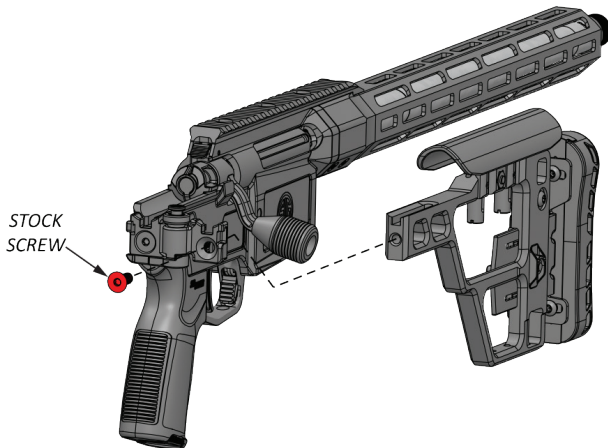



NOTE

Do not rotate or flip stock hinge assembly when reversing folding direction.

3. Use a T30® bit to remove stock hinge screw and stock hinge assembly from the receiver.
4. Reinstall the stock hinge assembly using the other hole and tighten to 50 in-lb.

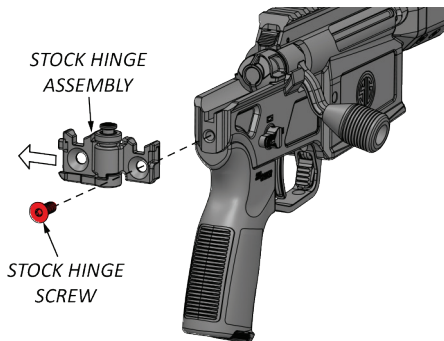

5. Reinstall the stock to the stock hinge assembly using a T30 bit and tighten stock screw to 50 in-lb.

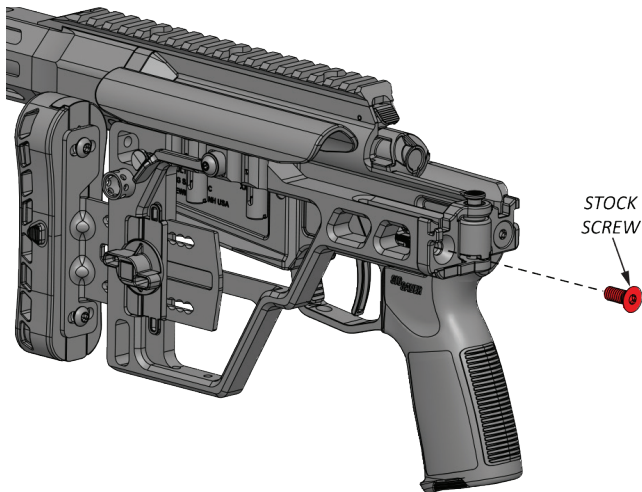



3.8 ADJUSTING TRIGGER



WARNING UNLOAD/CLEAR



PRIOR TO ADJUSTING THE CROSS RIFLE TRIGGER, ENSURE THAT THE FIREARM IS UNLOADED/CLEARED AND ON SAFE WITH THE BOLT REARWARD. FAILURE TO COMPLY COULD RESULT IN DEATH OR SERIOUS INJURY.



WARNING TRIGGER



THE TRIGGER ADJUSTMENT SCREW IS THE ONLY AUTHORIZED METHOD OF ADJUSTMENT TO THE TRIGGER MECHANISM. ATTEMPTING TO ADJUST OR MODIFY THE TRIGGER MECHANISM IN ANY OTHER WAY COULD RESULT IN DEATH OR SERIOUS INJURY AND DAMAGE TO THE FIREARM.

CAUTION

DO NOT ATTEMPT TO FORCE THE TRIGGER ADJUSTMENT SCREW BEYOND THE STOP OR INTERNAL DAMAGE TO THE RIFLE WILL RESULT.

1. The SIG SAUER CROSS rifle has a single T15[®] screw for trigger pull adjustment and can be adjusted between 2.5 and 4 pounds (approximately) without disassembling the rifle. The adjustment screw, located inside the trigger guard in front (towards the muzzle) of the trigger, is accessible through an opening in the trigger guard.
2. By turning the screw counterclockwise, the trigger pull will decrease. Likewise, turning the screw clockwise will increase the trigger pull. Changing the trigger pull screw setting affects both the first and second stages of the trigger pull. The two stages are not independently adjustable. Over-travel and creep are not adjustable by the user. The adjustment screw will stop at the maximum and minimum available trigger pull weight.

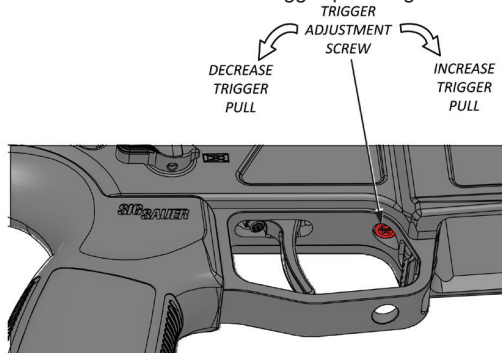



4.0 USER-LEVEL AUTHORIZED PREVENTIVE MAINTENANCE

4.1 FIELD STRIP THE SIG CROSS

4.1.1 REMOVE BOLT ASSEMBLY

1. Unload and clear the firearm of all ammunition. Ensure the safety selector lever is on SAFE.
2. If stock is set up for right side fold, press stock lock button and fold stock half way. If stock is set up for left side fold, press stock lock button and fully fold stock.
3. Lift bolt handle and rotate to it's upright position.
4. Press and hold bolt catch while pulling the bolt assembly to the rear and out of the receiver.

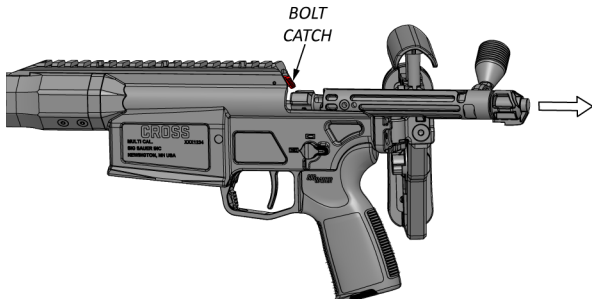

4.1.2 DISASSEMBLE BOLT ASSEMBLY

1. Grasp the bolt assembly with the bolt facing away.
2. Rotate the striker shroud counterclockwise to de-cock the striker.

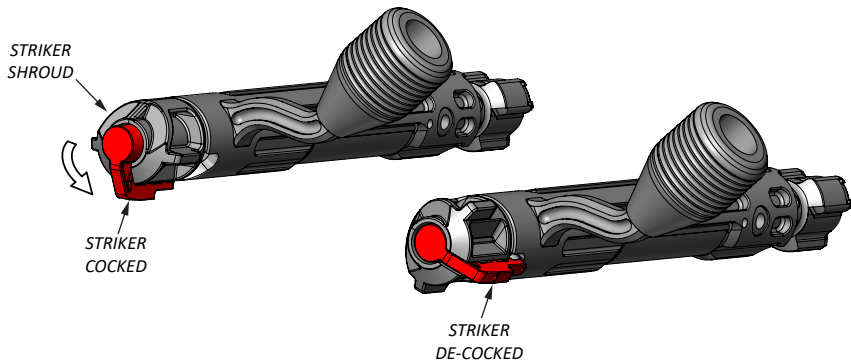



3. Hold the bolt assembly with the bolt face down against a hard flat surface.
4. Press down on the striker shroud while pulling the bolt handle away from the bolt carrier leaving a slight gap approximately the width of a quarter.

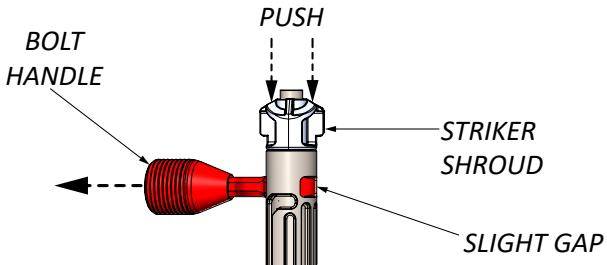

5. Release pressure on the striker shroud and pull the handle out to release the striker from the bolt carrier.

6. Grasp the striker shroud and pull the striker assembly from the bolt carrier.

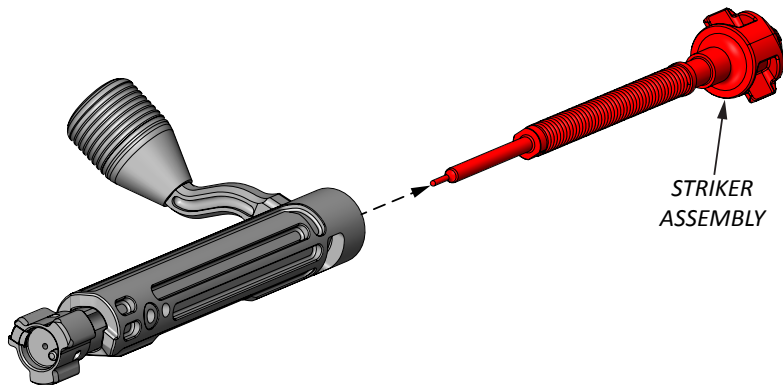



7. Remove the bolt handle.
8. Remove the bolt head pin.

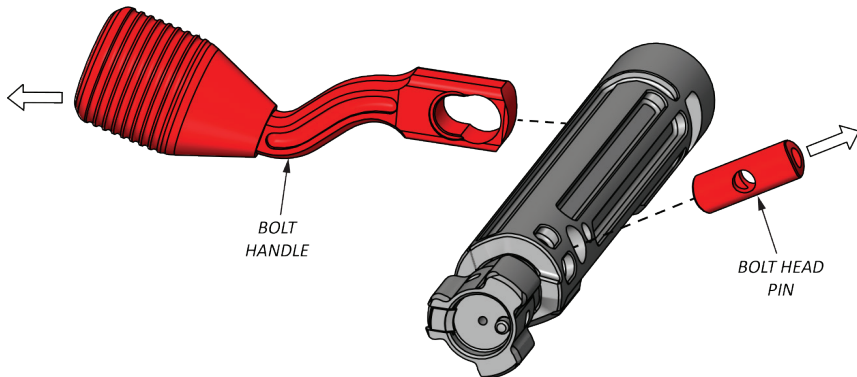

9. Remove bolt head assembly.

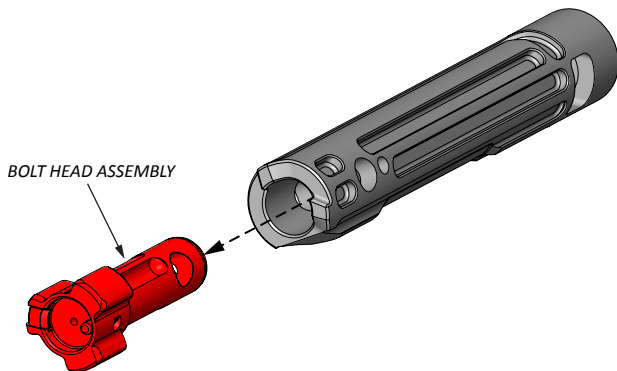

NOTE

No further disassembly of the bolt head assembly is authorized.



4.2 DISASSEMBLE MAGAZINE

1. Press and hold the tab on the magazine floorplate.

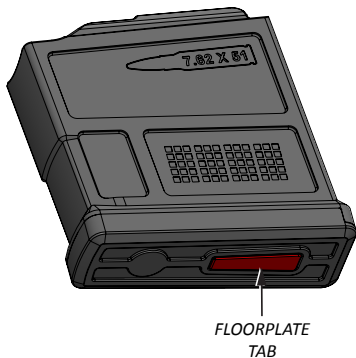

- Slide the magazine base plate forward and remove the floorplate, spring and follower from the magazine tube.

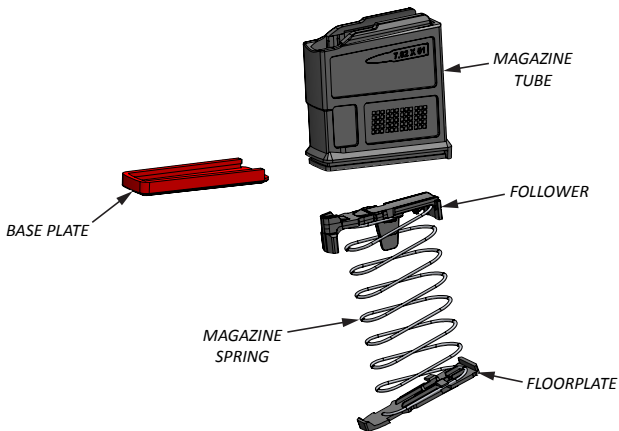



5.0 CLEANING AND LUBRICATION

- Always ensure the firearm is unloaded and cleared of all ammunition.
- Use only cleaning and lubrication products specifically designed for use on firearms.
- Do not use wire brushes on aluminum surfaces such as the receiver; this can scratch the finish.
- Follow all manufacturer instructions and cautions when using cleaning and lubricating products.
- Wherever the term “CLP” (Cleaner-Lubricant-Preservative) or the word “lubrication” are used in this manual, you should interpret it to mean that you can use any cleaner, lubricant, and preservative designed for use on a firearm.

5.1 CLEANING THE BORE AND CHAMBER

You should clean the bore of the CROSS with a high quality one-piece cleaning rod. Use a short chamber rod to clean the chamber. Avoid the use of metal or military sectional cleaning rods as they can damage the bore of the barrel.

1. Use a clean patch moistened with bore solvent and swab the chamber with the chamber rod.
2. Attach a nylon bristle chamber brush to chamber rod and scrub chamber.
3. Install nylon bore brush on chamber rod and scrub throat area of chamber.
4. Swab chamber with wet then dry patch until clean.
5. Attach a new clean patch moistened with bore solvent to the cleaning rod.
6. Push it completely through the bore from the chamber end. Repeat process, alternating between wet patches and dry patches until dry patches come out clean.

7. If barrel shows signs of heavy fouling replace jag with bore brush and push brush through bore from chamber end until brush is clear of muzzle. Repeat several times.
8. Run another patch moistened with bore cleaner through the bore to remove any heavy residue loosened by the bore brush.
9. Push new patches through the bore until they come out clean.
10. Soak a patch in a copper removal solvent designed for firearms and run it through the bore following the manufacturer instructions for use. If copper is present the patch will display a greenish/blue tint.
11. Repeat step 10 until patches indicate no copper is present.
12. Use a regular bore solvent or CLP to clean all remaining copper solvent from the bore.
13. If rifle is to be stored for extended period of time run one last patch moistened with CLP through the bore. Ensure you remove lubricant from bore prior to firing the rifle.

Barrel Break-In Procedure

This is suggested to obtain the best possible accuracy out of your firearm.

1. Clean the barrel as described in section “5.1 Cleaning the Bore and Chamber” on page 70.
2. Fire 1 shot, then clean per section 5.1. Repeat 5 times.
3. Fire 2 shots, then clean per section 5.1. Repeat 5 times.
4. Fire 5 shot, then clean per section 5.1. Repeat 5 times.

During your cleaning cycles, inspect the copper-solvent patch for green/blue color which indicates copper fouling. Use the copper removing solvent per the manufacturer instructions or as described in section 5.1 until the copper is removed, then continue with the break-in steps.



5.2 CLEANING THE BOLT ASSEMBLY

- A. Scrub bolt face with nylon bristle brush and CLP. Wipe off excess.
- B. Clean the hook of the extractor.
- C. Remove any carbon from bolt lugs.
- D. Scrub bolt head with nylon bristle brush and CLP. Wipe off excess.
- E. Clean interior of bolt carrier.
- F. Wipe down bolt handle.
- G. Wipe down bolt carrier body.
- H. Scrub the bolt head pin with nylon bristle brush and CLP. Wipe off excess.
- I. Wipe down the striker assembly.

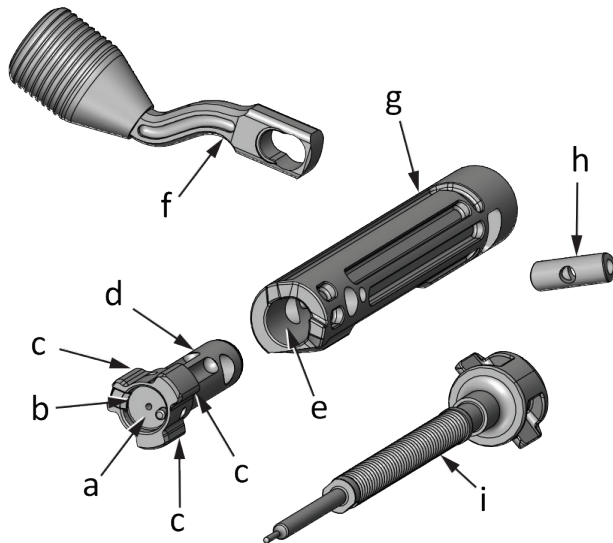



5.3 CLEANING RECEIVER AND EXTERIOR OF FIREARM

- Scrub interior of receiver with a soft bristle brush and CLP. Wipe off excess CLP.
- Wipe down exterior surfaces of firearm.

5.4 CLEANING MAGAZINE

- Remove any dirt, dust or debris from the magazine components with a rag or dry nylon bristle brush. Do not use lubricant, solvent, or metal bristle brushes when cleaning magazine.

5.5 LUBRICATING BOLT ASSEMBLY

- A. Apply 1-2 drops of lubricant to the extractor.
- B. Apply a small amount of grease to the side walls of the bolt latch pin groove in the top of the bolt carrier.
- C. Apply a small amount of grease to the camming surfaces of the bolt lugs, bolt carrier, and cocking cam at the rear of the bolt carrier.
- D. Apply a light coat of lubricant to the exterior of the bolt carrier, bolt handle, and bolt head pin.
- E. Apply a light coat of a molybdenum disulfide based anti-seize lubricant to the striker blade.
- F. Spread 2-3 drops of lubricant along the length of the striker spring with a nylon bristle brush.
- G. Apply a small amount of grease to the large diameter of the front of the striker pin.

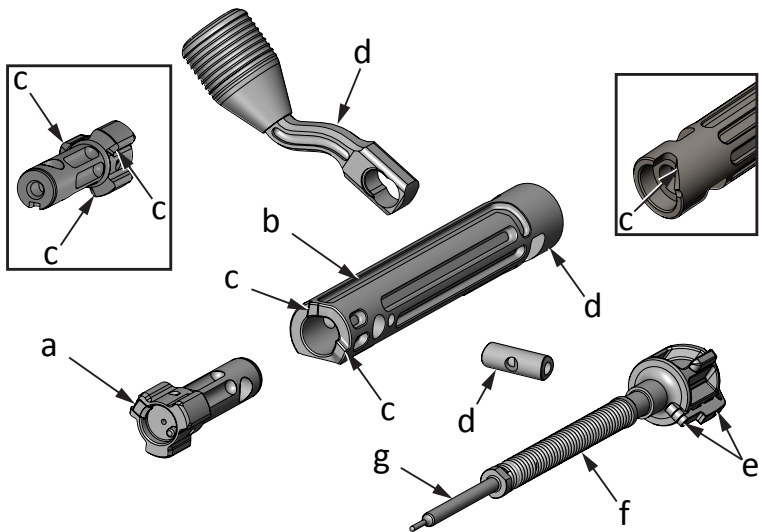



5.6 LUBRICATE RECEIVER AND EXTERIOR OF FIREARM

- A. Apply a light coat of lubricant to the interior of the receiver where the bolt assembly moves.
- B. Apply 1-2 drops of lubricant to the magazine release spring.
- C. Apply 1-2 drops of lubricant to the stock hinge.
- D. Apply 1-2 drops of lubricant of the bolt catch.
- E. Apply a light coat of a molybdenum disulfide based anti-seize lubricant to the sear surfaces.

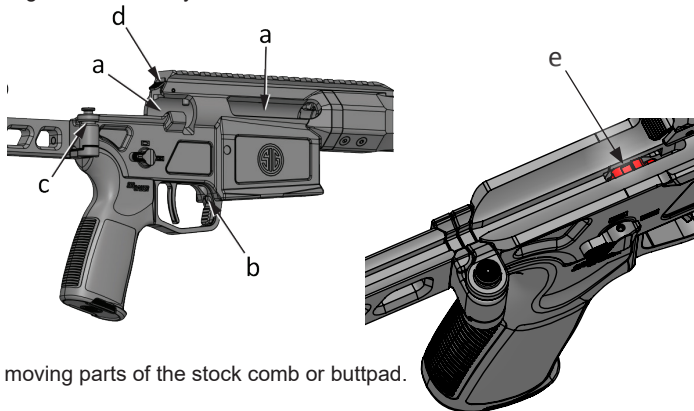

*Do not lubricate moving parts of the stock comb or buttpad.

6.0 REASSEMBLY

6.1 REASSEMBLE BOLT ASSEMBLY

NOTE

The bolt head assembly is keyed and can only be installed one way.

The 277 Fury bolt is identified by a "+" on the lug over the extractor.

1. Install the bolt head into the bolt carrier with the extractor on the right side and align the bolt head pin holes on the bolt head and carrier.

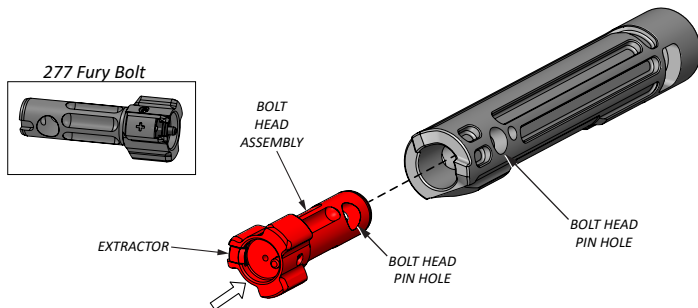



WARNING ASSEMBLY



BOLT HEAD PIN MUST BE INSTALLED WHEN REASSEMBLING CROSS. FAILURE TO PROPERLY INSTALL BOLT HEAD PIN MAY RESULT IN DEATH OR SERIOUS INJURY TO OPERATOR AND DAMAGE TO FIREARM.

2. Install bolt head pin with the firing pin hole aligned with the firing pin bore of the bolt carrier and bolt head.

CAUTION

THE BOLT HANDLE IS DESIGNED TO ONLY BE INSTALLED AS DESCRIBED IN THIS MANUAL. TRYING TO FORCE THE BOLT HANDLE INSTALLATION IN THE WRONG ORIENTATION CAN RESULT IN DAMAGE TO THE CROSS RIFLE.

3. Install bolt handle into the right side of the bolt carrier with the bolt knob down and the large diameter hole aligned with the firing pin bore.

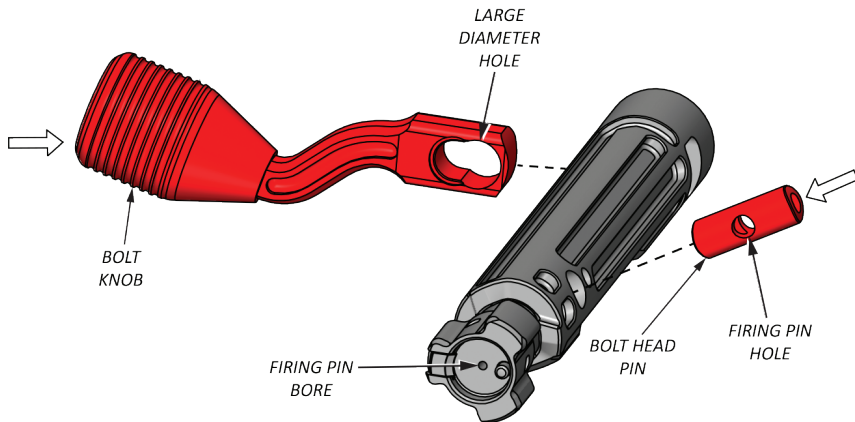



4. Insert striker assembly into the rear of the bolt carrier.

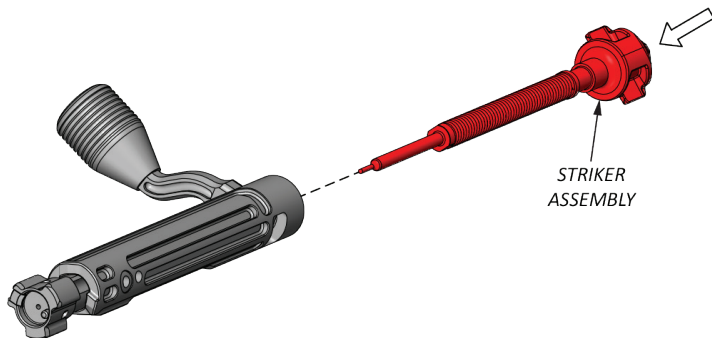

5. Press down firmly on the striker shroud and push the bolt handle until it stops. Release the striker shroud and ensure bolt handle cannot be pulled out.

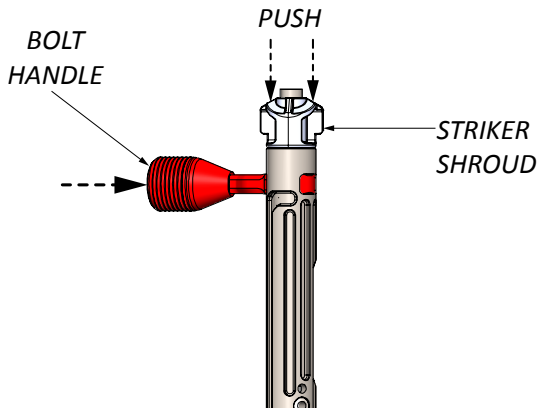



NOTE

Striker must be cocked in order to install bolt assembly.

6. Grasp striker shroud and twist firmly clockwise to cock striker.

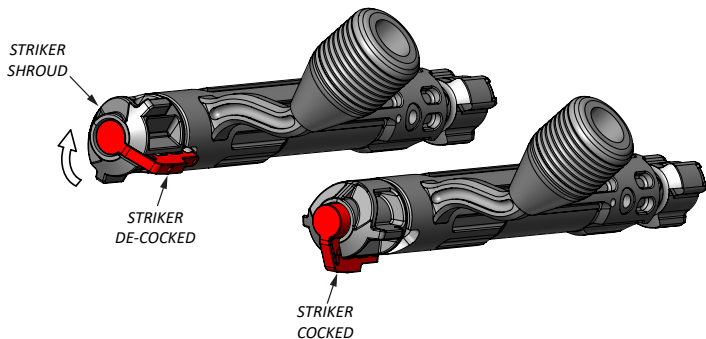

6.2 INSTALL BOLT ASSEMBLY

1. If stock is set up for right side fold, press stock lock button and fold stock halfway. If stock is set up for left side fold, press stock lock button and fully fold stock.
2. Insert bolt assembly into the back of the receiver.
3. Push forward until it stops.
4. Press and hold the bolt catch while pushing the bolt fully forward.
5. Push the bolt knob down into its locked position.

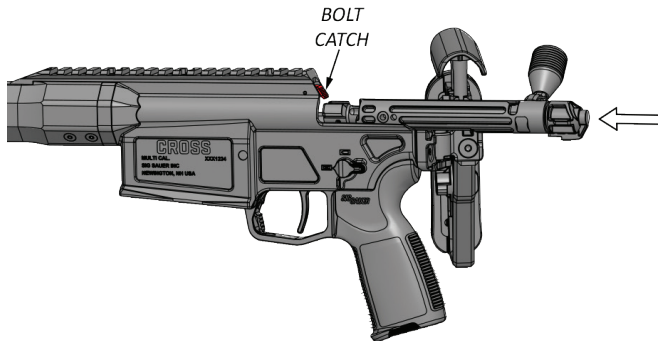



6.3 REASSEMBLE MAGAZINE

1. Insert follower, spring, and floorplate into magazine tube.
2. Compress spring until the bottom of the floorplate tab is level with the bottom of the magazine tube.
3. Slide the base plate onto the bottom of the magazine tube.

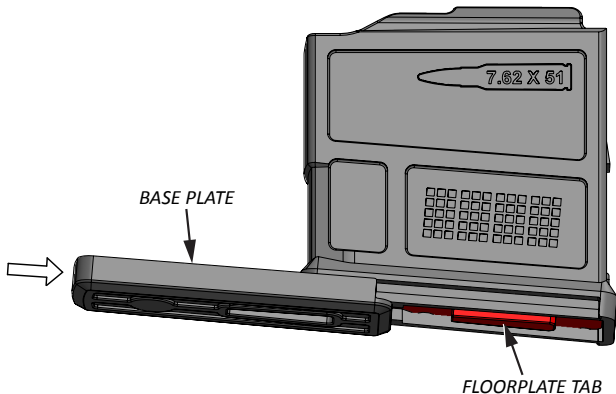

6.4 FUNCTION CHECK



WARNING UNLOAD/CLEAR



PRIOR TO STARTING THE FUNCTION CHECK, ENSURE THAT THE FIREARM IS UNLOADED AND CLEARED OF ALL AMMUNITION, AND ON SAFE WITH THE BOLT REARWARD. FAILURE TO COMPLY COULD RESULT IN DEATH OR SERIOUS INJURY. IF THE CROSS FAILS TO COMPLETE THE FUNCTION CHECK DO NOT USE THE FIREARM. CALL CUSTOMER SERVICE (SEE SECTION 10.0).

1. Insert an empty magazine into the magazine well and verify that it is fully seated by pulling it downward.
2. Push the bolt forward and rotate the handle down locking the bolt.
3. Rotate safety selector lever to SAFE.
4. Press magazine release. You should be able to pull the magazine free from the rifle with no resistance.
5. With the muzzle pointed in a safe direction and safety selector on SAFE, press trigger. Nothing should happen.
6. Rotate safety selector lever to FIRE position, press and hold trigger to the rear. You should hear the striker release.
7. Cycle the bolt, rotate the safety selector lever to SAFE and recheck SAFE by pressing the trigger.
8. Unlock the bolt and leave the bolt in the rearward open position.



6.5 TROUBLESHOOTING

| Stoppage | Test/Inspection | Corrective Action |
|--------------------------------------|--------------------------------------------------|---------------------------------------------------------------------|
| <i>Fails to Fire</i> | Selector lever on SAFE | Rotate to fire position |
| | Bolt handle not in the fully closed position | Ensure bolt handle is fully closed prior to firing |
| | Excessive lubricant in firing pin recess of bolt | Clean out lubricant |
| | Defective ammunition | Remove/discard |
| <i>Bolt is Hard to Unlock</i> | Dirty bolt | Clean, lubricate, and reinstall |
| | High pressure ammunition | Use only the correct ammunition, conforming to SAAMI specifications |
| | Burred bolt lugs | Contact Customer Service |
| <i>Failure to Feed</i> | Dirty/corroded ammunition | Replace ammunition |
| | Dirty magazine | Clean and replace |
| | Defective magazine | Replace |
| | Overloaded magazine | Remove excess rounds |
| | Magazine not seated | Seat magazine fully |

| Stoppage | Test/Inspection | Corrective Action |
|-------------------------------------|---------------------------------|---------------------------------------------------------------------|
| <i>Double Feed</i> | Defective magazine | Replace |
| <i>Failure to Chamber</i> | Dirty/corroded ammunition | Replace ammunition |
| | Damaged ammunition | Discard/replace |
| | Dirty chamber / feed ramps | Clean |
| <i>Bolt is Hard to Lock</i> | Dirty bolt lugs | Clean lugs |
| | Dirty chamber | Clean chamber |
| | Ammunition not to specification | Use only the correct ammunition, conforming to SAAMI specifications |
| <i>Failure to Extract</i> | Frozen extractor | Contact Customer Service |
| | Broken extractor spring | Contact Customer Service |
| | Missing extractor | Contact Customer Service |
| | Dirty/corroded ammunition | Replace ammunition |
| | Dirty chamber | Clean |
| <i>Frozen Selector Lever</i> | Needs lubricant | Lubricate |
| | Dirt/residue under trigger. | Clean |



6.6 CROSS RIFLE PARTS DIAGRAM

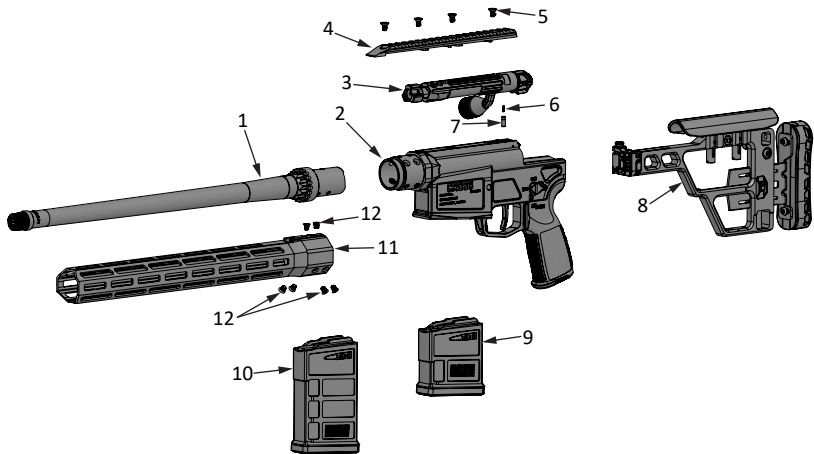

| NUMBER | NOMENCLATURE |
|---------------|------------------------------|
| 1 | Barrel Assembly |
| 2 | Receiver Assembly |
| 3 | Bolt Assembly |
| 4 | Receiver Rail |
| 5 | Receiver Rail Screws (4X) |
| 6 | Bolt Catch Pin Spring |
| 7 | Bolt Catch Pin |
| 8 | Stock Assembly |
| 9 | 5 Round Magazine |
| 10 | 10 Round Magazine (Optional) |
| 11 | Handguard |
| 12 | Handguard Screw (6X) |



6.7 BOLT ASSEMBLY PARTS DIAGRAM

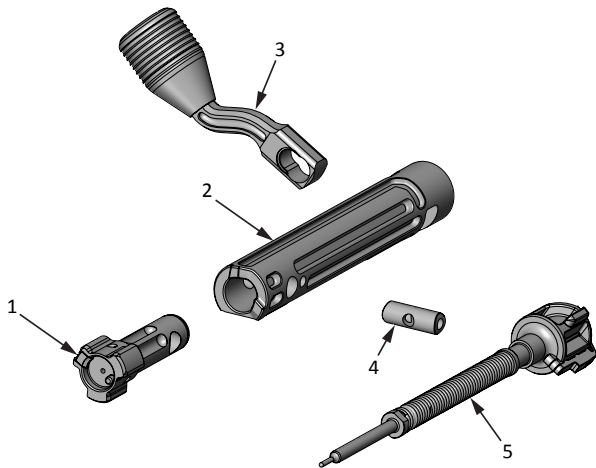

| NUMBER | NOMENCLATURE |
|---------------|---------------------|
| 1 | Bolt Head Assembly |
| 2 | Bolt Carrier |
| 3 | Bolt Handle |
| 4 | Bolt Head Pin |
| 5 | Striker Assembly |



7.0 OPTIONAL CONFIGURATIONS

7.1 CHANGING RECEIVER TOP RAIL

1. Use a T25® drive bit to remove the four receiver top rail screws.
2. Remove receiver top rail taking care not to dislodge the bolt catch pin and spring underneath.

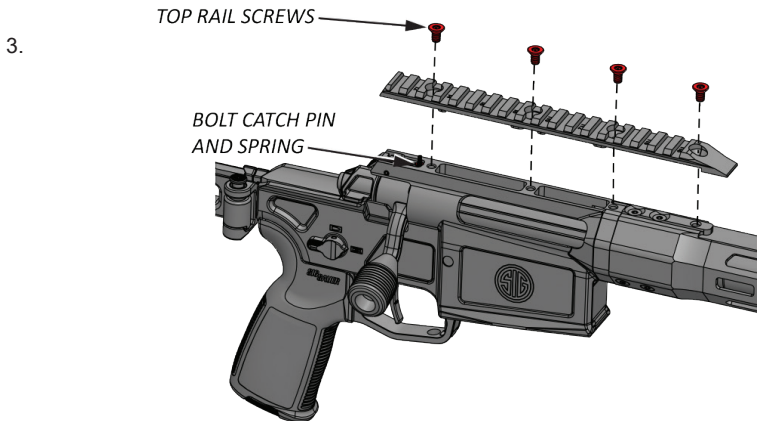

7.2 CHANGING BOLT KNOB

1. Use a T25® drive bit to unscrew the small bolt knob.
2. Use a T25® drive bit to screw on the optional large bolt knob.

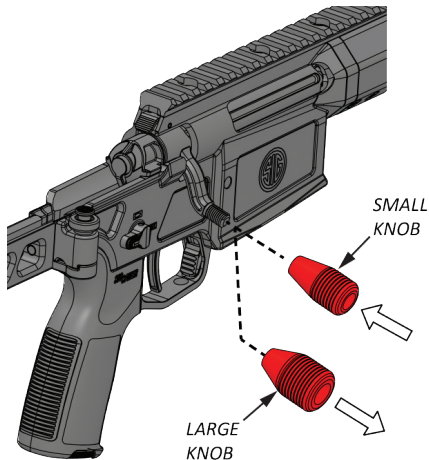



7.3 CHANGING THE BARREL

1. Remove stock assembly. See section “3.7.8 Reversing Stock Fold Direction” on page 57.
2. Remove the bolt assembly. See section “4.1.1 Remove Bolt Assembly” on page 62.
3. Remove the receiver top rail. See section “7.1 Changing Receiver Top Rail” on page 92.
4. Use a T15® drive bit to remove the six handguard screws.

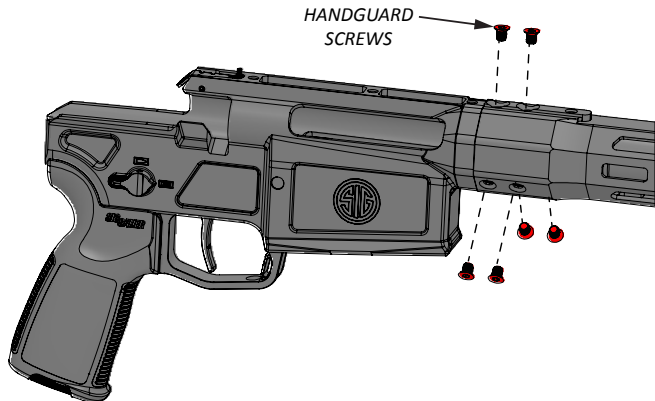

5. Remove the handguard.

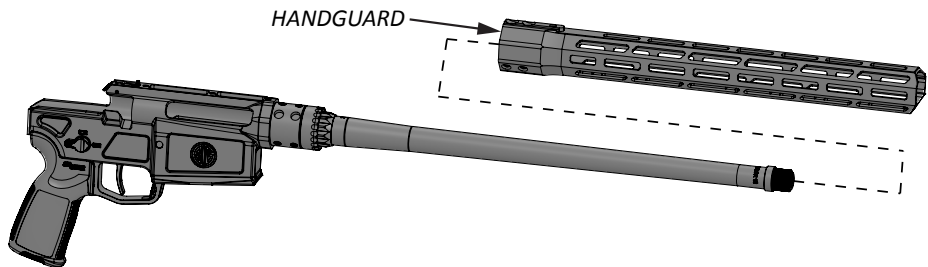



6. Insert barrel assembly tool into the rear of the receiver with a single lug down and the flats perpendicular to the top of the receiver. Ensure the assembly tool is fully inserted into the receiver and the lugs of the tool are engaged by the lugs of the barrel extension.

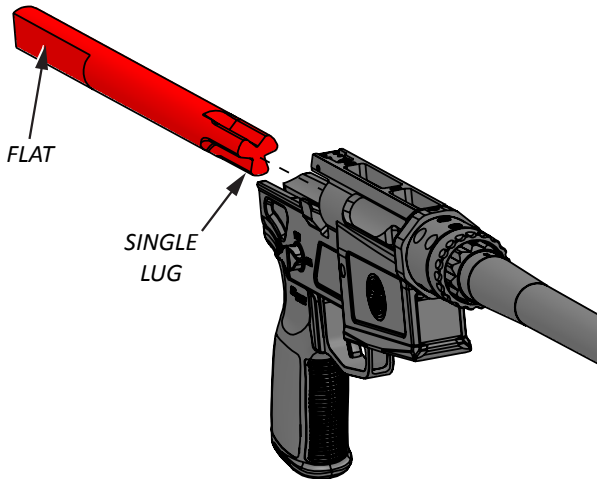

CAUTION

THE FRONT OF THE RECEIVER MUST BE SUPPORTED BY A WOODEN BLOCK OR SIMILAR OBJECT WHEN REMOVING OR INSTALLING THE BARREL. FAILURE TO DO SO MAY RESULT IN DAMAGE TO THE RECEIVER. DO NOT CLAMP RECEIVER IN VISE OR DAMAGE WILL RESULT.

7. Clamp the flats of the barrel assembly tool into a bench mounted vise.

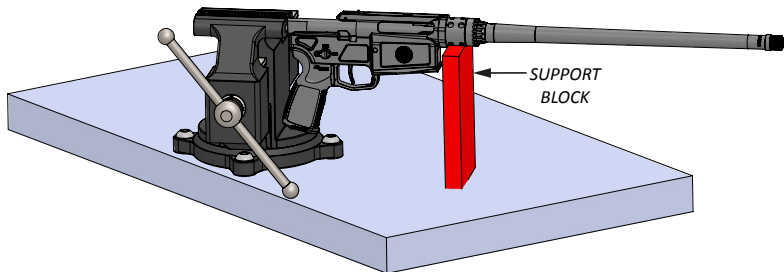



8. Using an AR barrel wrench, remove the barrel nut.

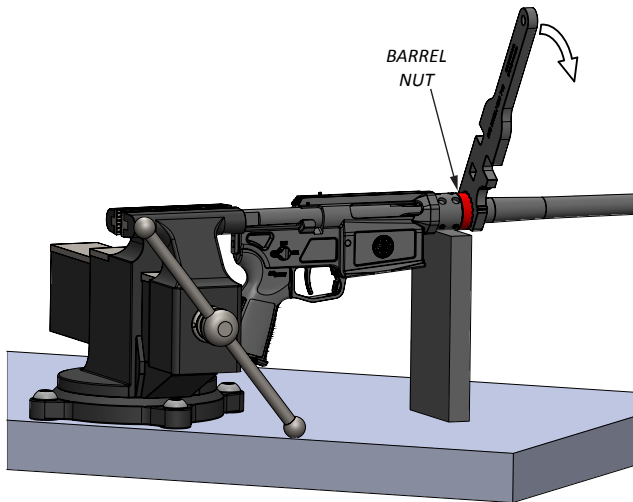

CAUTION

DO NOT WIGGLE OR TWIST BARREL WHILE REMOVING FROM RECEIVER OR DAMAGE WILL RESULT. IF BARREL DOES NOT COME OUT OF RECEIVER WHEN PULLED BY HAND, INSERT A WOODEN DOWEL INTO REAR OF RECEIVER AND GENTLY TAP OUT BARREL.

9. Remove barrel by pulling it out of the receiver.

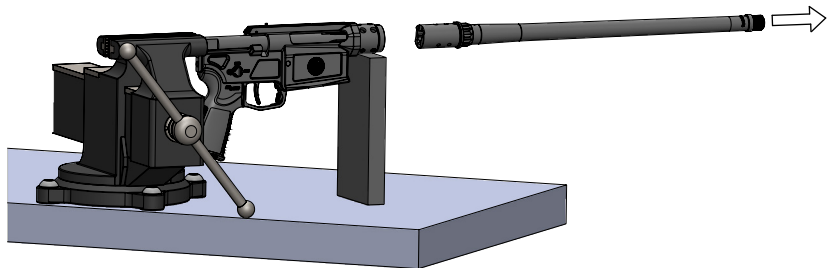



CAUTION

ENSURE THE INDEX PIN IN THE BARREL EXTENSION IS ALIGNED WITH THE INDEX NOTCH IN THE RECEIVER WHEN INSTALLING NEW BARREL. FAILURE TO PROPERLY ALIGN INDEX PIN WILL RESULT IN DAMAGE TO RECEIVER.

10. Insert new barrel into receiver and thread on barrel nut.

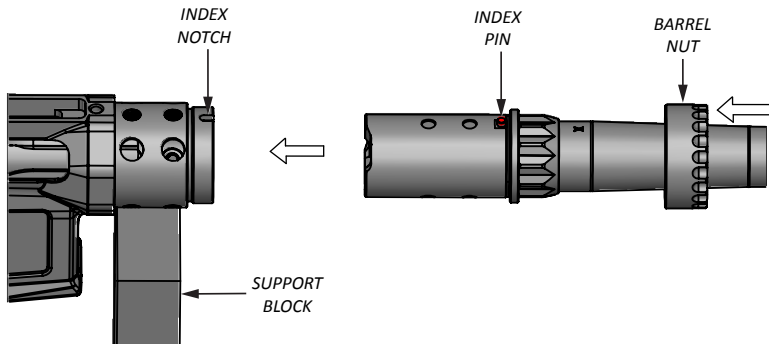

11. Insert torque wrench into AR barrel wrench with the handles of both wrenches parallel.
12. Pressing only on the torque wrench handle; torque barrel nut to 40 ft-lbs.

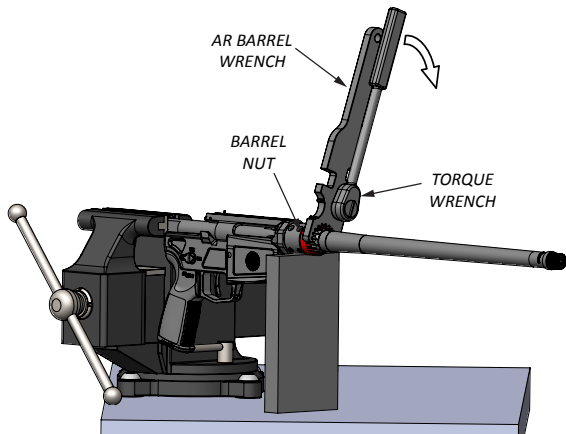



13. Replace handguard and torque screws to 30 in-lbs with a T15 drive bit.
14. Replace the receiver top rail. See section “7.1 Changing Receiver Top Rail” on page 92.
15. Replace the bolt assembly. See section “6.2 Install Bolt Assembly” on page 83.
16. Replace stock assembly See section “3.7.8 Reversing Stock Fold Direction” on page 57.
17. Conduct a function check. See section “6.4 Function Check” on page 85.

8.0 TRANSPORTATION AND STORAGE



WARNING STORAGE

NEVER PLACE OR STORE ANY FIREARM IN SUCH A MANNER THAT IT MAY BE DISLODGED. FIREARMS SHOULD ALWAYS BE STORED SECURELY AND UNLOADED, AWAY FROM CHILDREN AND OTHER UNAUTHORIZED USERS. THE USE OF A LOCKING DEVICE OR SAFETY LOCK IS ONLY ONE ASPECT OF RESPONSIBLE FIREARMS STORAGE. FOR INCREASED SAFETY, FIREARMS SHOULD BE STORED UNLOADED AND LOCKED IN A LOCATION THAT IS BOTH SEPARATE FROM THEIR AMMUNITION AND INACCESSIBLE TO CHILDREN AND ANY OTHER UNAUTHORIZED PERSON. STORE SECURELY AND UNLOADED

Short-Term Storage (90 days or less)

1. Ensure that the chamber and magazine do not contain live ammunition.
2. Clean the bore and chamber
3. Apply a generous coat of CLP to the chamber and bore.
4. Apply a light coat of CLP to all other metal surfaces for corrosion protection.
5. Do not attempt to store a firearm with a warm or hot suppressor.
6. Adjust the buttstock to its shortest length to reduce the chances of damage.



Long-Term Storage (90 days or longer)

1. Ensure that the SIG CROSS is thoroughly cleaned.
2. Apply a medium coat of CLP to the chamber and bore.
3. Adjust the buttstock to its shortest length to reduce the chances of damage.
4. Apply a light coat of CLP to all other metal surfaces for corrosion protection.
5. Wrap the SIG CROSS with a waterproof material (MIL-B-121 or similar).
6. Place the SIG CROSS in a corrosion resistant barrier bag (MIL-DTL-117 or similar).

Environmental Storage Recommendations (Armory)

Provide humidity control to limit the relative humidity (RH) to no greater than 40% at 80°F (26.7°C). If personnel will be working in these areas, design to 68°F (20.0°C) dry bulb and 40% RH for indoor design heating conditions, and 75°F (23.9°C) dry bulb and 40% RH for indoor design cooling conditions.

9.0 REPLACEMENT PARTS POLICY



WARNING

IT IS THE PURCHASER'S RESPONSIBILITY TO BE ABSOLUTELY CERTAIN THAT ANY PARTS ORDERED FROM THE FACTORY ARE CORRECTLY FITTED AND INSTALLED. FIREARMS ARE COMPLICATED MECHANISMS AND IMPROPER FITTING OF PARTS MAY RESULT IN A DANGEROUS MALFUNCTION, DAMAGE TO THE FIREARM, AND SERIOUS INJURY TO THE SHOOTER AND OTHER PERSONS. THE PURCHASER AND INSTALLER OF PARTS MUST ACCEPT FULL RESPONSIBILITY FOR THE CORRECT ADJUSTMENT AND FUNCTIONING OF THE FIREARM AFTER SUCH INSTALLATION.

Parts Policy

Our Service Department maintains a full complement of replacement parts. Even though most gunsmiths have the knowledge, training, and the ability to make necessary repairs to your firearm, the skill and workmanship of any particular third-party gunsmith is totally beyond our control.

Should your firearm ever require service, we strongly recommend that you return it to SIG SAUER Inc. A firearm is a precision instrument and some replacement parts will require individual fitting to ensure correct operation. A wrong part, improper fitting, or incorrect mechanical adjustment may result in an unsafe condition or dangerous malfunction, damage to the firearm, or cause possible serious injury to the shooter or others.



IF ANY PART IS ORDERED WITHOUT RETURNING THE FIREARM TO SIG SAUER, Inc. the customer bears full responsibility for ensuring that the part supplied is correct for their particular firearm and is properly installed and fitted by a qualified gunsmith.

SIG SAUER INC. IS NOT RESPONSIBLE FOR THE FUNCTIONING OF ANY FIREARM IN WHICH REPLACEMENT PARTS ARE INSTALLED BY OTHERS.

THE USE OF AFTERMARKET PARTS IS NOT AUTHORIZED AND WILL VOID THE WARRANTY OF THIS FIREARM. THE REPLACEMENT OF ORIGINAL EQUIPMENT MANUFACTURER (OEM) SIG SAUER PARTS WITH AFTERMARKET PARTS IS UNAUTHORIZED AND IN SOME INSTANCES COULD ALTER THE FUNCTION OF THE FIREARM, CREATING A DANGER TO THE OPERATOR.

Scan the QR code below which will take you to the Small Parts Shopper page at sigsauer.com.



10.0 FACTORY REPAIR OF YOUR FIREARM

If you have questions or concerns regarding the performance or serviceability of your firearm, there are two ways to contact Customer Service:

Before contacting Customer Service, have your firearm's serial number readily available.

1. Call us at (603) 610-3000, choose option 1.
2. Go to <https://www.sigsauer.com/customer-support> where you can message customer service electronically. Scan the QR code below which will take you to the Customer Support page at [sigsauer.com](https://www.sigsauer.com).

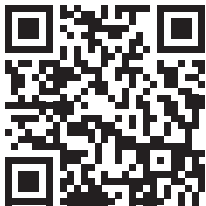



10.1 RETURNING FIREARMS FOR REPAIR

Please do not ship your firearm until you obtain an RMA number from Customer Service.



WARNING DO NOT SHIP AMMUNITION



BEFORE SHIPPING ANY FIREARM, BE ABSOLUTELY CERTAIN THAT THE FIREARM AND ANY MAGAZINES ARE UNLOADED. DO NOT SHIP AMMUNITION WITH A FIREARM.

1. The RMA number allows SIG SAUER to track the status of your return from its receipt at SIG SAUER through its return to you.
2. Ensure that the chamber and magazine(s) are unloaded and that no ammunition is included with your returned firearm.
3. Package the firearm securely to prevent damage. With the exception of extra magazines, do not include any other accessories such as scopes or mounts unless directed to do so.
4. Generally, an individual may ship firearms to the manufacturer for repair or service. Some states and localities, however, prohibit this. If you live in such an area, the firearms must be shipped by and returned to a federally licensed firearms dealer.
5. Federal law prohibits persons who do not possess a Federal Firearms License (FFL) from shipping a firearm via the U.S. Postal Service. (Note: any shipment of firearms outside U.S. borders is subject to the export laws of the United States and to the valid laws of the specific country, which you must strictly follow; prior to exporting any firearm you should seek legal counsel.)

6. SIG SAUER is not responsible for any firearm until it is received, nor for damage incurred during shipment.
7. Ship your firearms insured and prepaid (we do not accept collect shipments) to the address provided by Customer Service.

| CALIBER | | | CARTRIDGE | | | BARREL | | |
|-------------|----------|------------------|-----------------|-----------|------------|-----------------|------------------|-------------------|
| RANGE (YDS) | Mv (FPS) | ENERGY (FT-LBS) | TRAJECTORY (IN) | ADJ (MOA) | ADJ (MILS) | WIND DRIFT (IN) | WIND DRIFT (MOA) | WIND DRIFT (MILS) |
| 100 | | | | | | | | |
| 200 | | | | | | | | |
| 300 | | | | | | | | |
| 400 | | | | | | | | |
| 500 | | | | | | | | |
| 600 | | | | | | | | |
| 700 | | | | | | | | |
| 800 | | | | | | | | |
| 900 | | | | | | | | |
| 1000 | | | | | | | | |



| CALIBER | | | CARTRIDGE | | | BARREL | | |
|----------------|-------------|---------------------|--------------------|--------------|---------------|--------------------|---------------------|----------------------|
| RANGE (YDS) | Mv (FPS) | ENERGY (FT-LBS) | TRAJECTORY (IN) | ADJ (MOA) | ADJ (MILS) | WIND DRIFT (IN) | WIND DRIFT (MOA) | WIND DRIFT (MILS) |
| 100 | | | | | | | | |
| 200 | | | | | | | | |
| 300 | | | | | | | | |
| 400 | | | | | | | | |
| 500 | | | | | | | | |
| 600 | | | | | | | | |
| 700 | | | | | | | | |
| 800 | | | | | | | | |
| 900 | | | | | | | | |
| 1000 | | | | | | | | |

| CALIBER | | | CARTRIDGE | | | BARREL | | |
|----------------|-------------|---------------------|--------------------|--------------|---------------|--------------------|---------------------|----------------------|
| RANGE (YDS) | Mv (FPS) | ENERGY (FT-LBS) | TRAJECTORY (IN) | ADJ (MOA) | ADJ (MILS) | WIND DRIFT (IN) | WIND DRIFT (MOA) | WIND DRIFT (MILS) |
| 100 | | | | | | | | |
| 200 | | | | | | | | |
| 300 | | | | | | | | |
| 400 | | | | | | | | |
| 500 | | | | | | | | |
| 600 | | | | | | | | |
| 700 | | | | | | | | |
| 800 | | | | | | | | |
| 900 | | | | | | | | |
| 1000 | | | | | | | | |



SIG SAUER® INFINITE GUARANTEE®

SIG SAUER® has a history of quality and reliability that dates back more than 250 years. We understand the importance of true dependability whether it be in the line of duty, at the shooting range or on your next hunt and we continually strive to deliver products that meet and exceed the expectations of even the most demanding customers. That's why SIG SAUER is proud to offer our INFINITE GUARANTEE* on all our firearms, optics, and suppressors.

Our promise: We warrant that your new SIG SAUER firearm, optic, or suppressor was originally manufactured free of defects in material, workmanship, electrical, optical, and mechanical function. We will repair your SIG SAUER product in the event it becomes damaged or is defective in any way, at no charge to you. If we cannot repair your product, we will replace it or, if we cannot replace it, we will provide you with a replacement of equal value. All with no questions asked, forever.

SIG SAUER® Infinite Guarantee®

- Fully Transferable
- No Warranty Card Required
- No Receipt Required
- No Time Limit Applies
- No Charge

Please note that our Infinite Guarantee excludes coverage for intentional damage, misuse, cosmetic damage that does not affect the performance of the optic, loss, theft, or unauthorized repair or modification. Excludes Tritium components.

Customers seeking warranty coverage must first obtain a Return Merchandise Authorization (RMA) by contacting SIG SAUER Customer Service and return the product unloaded and freight prepaid.

ANY WARRANTIES IMPLIED BY LAW, INCLUDING ANY IMPLIED WARRANTIES OF MERCHANTABILITY OR FITNESS FOR A PARTICULAR PURPOSE, ARE EXPRESSLY LIMITED IN DURATION TO THE DURATION OF THIS WRITTEN WARRANTY PERIOD. REPAIR, ALTERATION, OR REPLACEMENT AS PROVIDED HEREIN IS YOUR EXCLUSIVE REMEDY FOR ANY DEFECTIVE PRODUCT. IN NO EVENT SHALL SIG SAUER OR ANY COMPANY AFFILIATED WITH SIG SAUER BE LIABLE FOR ANY SPECIAL, INCIDENTAL, OR CONSEQUENTIAL DAMAGES OF ANY KIND ARISING OUT OF THE PURCHASE OR USE OF THIS PRODUCT, WHETHER BASED UPON CONTRACT, TORT, STATUTE, OR OTHERWISE. Some states do not allow the limitation of implied warranties, or the exclusion or limitation of incidental or consequential damages, so some or all of the above limitations or exclusions may not apply to you. This warranty gives you specific legal rights, and you may also have other rights which vary from State to State.

This warranty applies to commercial customers only and does not apply to government, non-commercial, or non-US customers. Non-US COMMERCIAL CUSTOMERS MUST PURCHASE PRODUCT THROUGH AN AUTHORIZED SIG SAUER DEALER WITHIN THEIR COUNTRY OF RESIDENCE FOR THIS WARRANTY TO APPLY.

SIG SAUER®

sigsauer.com

**SIG SAUER, Inc.
72 Pease Boulevard, Newington, NH 03801 USA**

All trademarks, service marks, trade names, trade dress, product names, and logos appearing in this manual are the property of their respective owners. No trademark or service mark appearing in this manual may be used without written consent of the mark's owner.