

SIG SAUER®



SIG SAUER P211®

OPERATOR'S MANUAL: HANDLING & SAFETY INSTRUCTIONS



READ THE INSTRUCTIONS AND WARNINGS IN THIS MANUAL CAREFULLY BEFORE USING THIS FIREARM.



WARNINGS



WARNINGS

SIGSAUER



WARNING

BEFORE OPERATING THE FIREARM, REVIEW THE SAFETY WARNINGS MANUAL THAT WAS PROVIDED WITH THE FIREARM. ALTERNATIVELY, REFER TO SIGSAUER.COM FOR THE LATEST SAFETY WARNING INFORMATION.

For more information, scan the QR code below to visit [sigsauer.com](https://www.sigsauer.com).

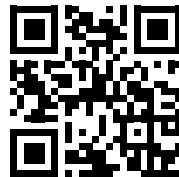



WARNINGS

1.0 SAFETY WARNINGS

READ THIS ENTIRE MANUAL THOROUGHLY AND CAREFULLY PRIOR TO USING THIS FIREARM.

SIG SAUER, INC.® firearms are designed to function reliably with proper care and knowledgeable use. Operators must understand the safe operation and use of any SIG SAUER firearm. Read and follow these instructions carefully. Do not use the firearm without understanding the instructions outlined in this manual and the safe operation of the firearm. Failure to follow the instructions outlined in this manual may result in serious injury or death to the operator and/or others. Damage to the firearm and other property may also occur.

The warnings in this Operator's Manual are extremely important. By understanding the dangers inherent in the use of any firearm, and by taking the precautions described in this manual, you can experience a high level of safety in the use of your firearm. Failure to heed any of these warnings may result in serious injury or death to you or others, as well as severe damage to the firearm or other property.



WARNINGS

SIG SAUER

WARNINGS in this manual identify a clear danger to the person performing that procedure. Warnings are identified by a red banner with the word **WARNING** in white, bold, uppercase letters and a **WARNING** icon. Failure to comply with a **WARNING** can result in serious injury or death to you or a bystander.



WARNING

CAUTIONS in this manual identify a risk of damage to the firearm being maintained. **CAUTIONS** are identified by a black banner with the word **CAUTION** in white, bold, uppercase letters.

CAUTION



WARNINGS

2.0 HANDLING

2.1 SAFETY MECHANISMS

MANUAL SAFETY

Consistent with individual operators' philosophies of use, SIG SAUER offers pistols with and without a manual safety, and the decision whether to deploy a manual safety rests with the operator. This is an important decision that must consider several factors, including the intended use of the firearm (e.g., law enforcement, defensive carry, home defense, range use, competition), level of firearms experience and training, frequency of practice, holster selection, and carry position, among others. The internal safeties are designed to prevent it from firing without the trigger being fully pulled. When the trigger is pulled or depressed, even unintentionally—whether by a finger or foreign object—the firearm will fire as designed. When engaged, a manual safety locks the trigger and prevents it from being accidentally or intentionally pulled, providing additional protection from unintentional discharge. However, an engaged manual safety will also prevent an operator from firing their pistol even when they need it to fire if the manual safety is not first disengaged.

SIG SAUER encourages those considering the purchase of a firearm to carefully evaluate whether a manual safety would be the best choice for them.



WARNINGS

SIG SAUER

Regardless of whether a firearm is equipped with an external manual safety, it remains the operator's obligation to continue to practice safe firearm handling. Firearms should always be treated as loaded and must be handled in a safe manner even if the firearm is equipped with a manual safety. Trigger discipline and utilizing an appropriate holster that protects the trigger when a firearm is being carried are of paramount importance even for firearms that have a manual safety (as the pistol can be carried with the safety in a disengaged condition). Be advised, however, that holsters, while offering further trigger protection, do not prevent accidental discharges as it may be possible for a foreign object to get into the holster, particularly with light-bearing holsters. Extreme caution should be taken when holstering and unholstering a pistol to ensure nothing gets into the holster. Pistol safeties, whether internal or external, should never be relied upon to excuse undisciplined handling of a firearm.

This firearm may not have a manual safety if you have made the decision, based on the factors above, to purchase a gun without a manual safety. A manual safety – when engaged -- is designed to mechanically prevent the firearm from discharging when the trigger is pulled or pressed, either intentionally or unintentionally. **THE MOST EFFECTIVE SAFETY IS TO CARRY YOUR PISTOL WITHOUT A ROUND IN THE CHAMBER, AND TO LOAD A ROUND IN THE CHAMBER ONLY WHEN READY TO FIRE.** Regardless of whether your firearm is equipped with a manual safety you must take steps to protect against unintentional movement of the trigger, particularly if you elect to carry your pistol with a round in the chamber. If you have a round in the chamber and the trigger is pressed to the rear, the firearm will fire absent an engaged manual safety.



WARNINGS

A manual safety is designed to augment, not replace, safe firearm handling practices. You are responsible to protect against inadvertent trigger movement while carrying any firearm. Even if your firearm is equipped with a manual safety, you must ensure that the trigger is not contacted in any circumstance—whether by finger or an object—other than when you intend to discharge the firearm.

2.1.1 BASIC RULES OF SAFE FIREARMS HANDLING

- ALWAYS treat every firearm as if it were loaded.
- ONLY load a round in the chamber when ready to fire.
- NEVER pull the trigger or place fingers on the trigger or in the trigger guard until ready to fire.
- NEVER allow clothing or other foreign objects to interfere or come in contact with the trigger.
- ALWAYS carry a pistol in a holster specifically designed for that pistol. It is the responsibility of the customer to ensure the holster is compatible with their specific pistol and any installed accessories.
- ALWAYS be sure the barrel is clear of any obstruction.
- ALWAYS be aware of the surroundings, and the safety of bystanders, before shooting. Know the target and what is in front of and beyond it.
- ALWAYS use clean, dry, original factory-made ammunition of the proper type and caliber for the firearm.
- ALWAYS wear ear protection and safety glasses when shooting.



WARNINGS

SIG SAUER

- ALWAYS carry a firearm so that control of the muzzle can be maintained in the event of a fall or stumble.
- NEVER shoot at a flat surface or water.
- DO NOT leave a loaded firearm unattended. Only store a firearm that is unloaded, cleared of all ammunition, and locked in a secure place inaccessible to children or unauthorized persons.
- NEVER allow the firearm to be used by anyone who has not read and understood the Operator's Manual.
- ALWAYS unload and clear a firearm according to the instructions in the Operator's Manual before handing it to another person.
- DO NOT point any firearm, loaded or unloaded, at any undesignated or unsafe target.
- NEVER discharge a firearm near an animal unless the animal is trained to accept the noise. An animal's startled reaction could injure it or cause an accident.
- NEVER drink alcoholic beverages or use drugs before or during shooting, as vision and judgment could be seriously impaired, making firearm handling unsafe.
- ALWAYS seek a doctor's advice before using a firearm if using medication that would impair judgment or usage.



WARNINGS

2.2 ABUSIVE HANDLING

SIG SAUER firearms incorporate effective mechanical safeties. However, like any mechanical device, exposure to abusive conditions may harm these safety mechanisms and cause them to fail to work as designed. Do not subject the SIG SAUER firearm to any abusive handling. This includes the firearm being dropped, impact to the firearm, or the firearm being struck by another object. Always maintain control of the firearm. If the firearm suffers an abusive event such as previously described, or experiences a malfunction, do not attempt to use the firearm. Keep the firearm pointed in a safe direction, unload and clear the firearm of all ammunition immediately, and have it inspected by a certified SIG SAUER armorer before using the firearm.

ALWAYS keep the firearm pointed in a safe direction. A safe direction is defined as an area where, if the firearm were to discharge, no property damage would occur, and no personal injury would result.

As previously noted, if the SIG SAUER firearm suffers an abusive event, unload it immediately and have it inspected by a certified SIG SAUER Armorer prior to using the firearm. If the firearm suffers an abusive event during a life-threatening/self-defense situation, follow the steps below immediately:

1. Pull the slide entirely rearward to eject the chambered cartridge.
2. Release the slide to chamber a new cartridge and reset the trigger mechanism. (Do not ride the slide forward.)
3. The firearm should now be returned to proper operational condition.

Intentional or repetitive abusive handling of any SIG SAUER firearm will void the manufacturer's warranty and could render the firearm unsafe.



WARNINGS

SIG SAUER

3.0 ALTERATIONS AND REPLACEMENT PARTS

Do not attempt to disassemble a SIG SAUER firearm beyond the point explained in the Operator's Manual. Disassembly beyond the instructions in the Operator's Manual is restricted to a certified SIG SAUER Armorer. Failure to comply with these restrictions will void the warranty.

This SIG SAUER firearm was designed to function properly in its original condition. Unauthorized alterations can make it unsafe. Do not alter or substitute any parts in the firearm with parts or accessories not manufactured or not specifically authorized by SIG SAUER. Warnings and instructions about the use of SIG SAUER replacement parts, assemblies, and accessories may be described in instructions accompanying the specific products. Read and carefully follow those instructions. Failure to comply may result in serious injury or death to the operator and/or others. The use of aftermarket replacement parts is unauthorized and, in some instances, could alter the function of the firearm.



WARNINGS

3.1 ACCESSORIES

It is the responsibility of the operator to ensure all accessories are compatible with the firearm and do not interfere with the safe operation and handling of the firearm.

3.1.1 HOLSTERS

A properly designed holster protects the trigger from being contacted inadvertently when the firearm is holstered.

- Make sure the holster is designed to accept the specific accessories installed on the firearm. Holsters for firearms equipped with a tactical light may have large openings to accommodate the bezel of the light, rendering the trigger area of the holstered firearm accessible to foreign objects or fingers if a light is not installed or if the holster is not sized specifically for use with the light that is installed on the firearm.
- Ensure the holster will protect the pistol while seated in a vehicle from surrounding features or devices in the vehicle that could interfere with the safe carry of the pistol. For example, entering and exiting the vehicle without the seat belts becoming snagged on the firearm or the holster.

Read and follow all warnings and instructions that are provided by the holster manufacturer before using. Failure to follow the instructions may result in serious injury or death to the operator and/or others.



WARNINGS

SIG SAUER

3.2 TRANSPORTING

When transporting a firearm, be sure the firearm is unloaded and cleared of all ammunition. It is the responsibility of the operator to know the laws of different states and jurisdictions when traveling with a firearm.

3.3 STORAGE

Safe and secure storage is an important responsibility. The only safe way to store a firearm is unloaded, cleared of all ammunition, and locked in a secure place inaccessible to children or unauthorized persons.

3.4 CHAMBER SAFETY FLAG

Every SIG SAUER firearm is shipped with a chamber safety flag. When installed, the chamber safety flag prevents the chambering of a round and provides a readily visible indication that the firearm's chamber is empty. The chamber safety flag is to be placed in the firearm's chamber at all times when the firearm is not in use. Many public ranges require chamber safety flags be installed when the firing line is cold.



WARNINGS

3.5 LIABILITY

PISTOLS and RIFLES are classified as FIREARMS and are sold by SIG SAUER with the specific understanding that SIG SAUER shall not be responsible in any manner whatsoever for malfunctioning of the firearm, physical injury, or property damage resulting in whole or in part from:

- **Criminal or negligent discharge**
- **Improper, careless, or abusive handling**
- **Unauthorized modifications or parts replacement**
- **Defective, improper, hand-loaded, or reloaded ammunition**
- **Corrosion**
- **Neglect**
- **Other influences beyond our direct and immediate control**

This limitation applies regardless of whether liability is asserted on the basis of contract, negligence, or strict liability (including any failure to warn). Under no circumstance shall SIG SAUER, Inc., be liable for incidental or consequential damages such as loss of use of property, commercial loss, and loss of earnings or profits.



WARNINGS

SIG SAUER

4.0 EYE AND EAR PROTECTION

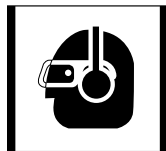

Always wear safety glasses that meet the requirements of American National Standards Institute (ANSI) z87.1 or European Standard (EN)166:2001 and ear plugs and “ earmuff ” type protectors whenever shooting. Always make certain that persons close are similarly protected. Unprotected eyes may be injured by powder, gas, carbon residue, lubricant, metallic particles, or similar debris that may emanate occasionally from any firearm in normal use. Without ear protection, repeated exposure to shooting noise may lead to cumulative, permanent hearing loss.

5.0 AMMUNITION

Use only high-quality, original, factory-manufactured ammunition. Do not use cartridges that are dirty, wet, corroded, bent, or damaged. A damaged or deformed cartridge may impede chambering or cause the cartridge case to burst upon firing. Do not oil cartridges. Lubricant or other foreign matter on cartridges can potentially cause dangerous ammunition malfunctions. Some highly penetrative lubricants can also migrate inside cartridge cases and cause deterioration of the propellant powder; on firing, the powder might not ignite. If only the primer ignites, there is danger that the bullet may become lodged in the barrel. Only use ammunition of the caliber for which the firearm is chambered.

The proper caliber is permanently engraved on the firearm’s barrel.



WARNINGS

The use of reloaded, hand-loaded (re-manufactured), or other nonstandard ammunition voids all warranties. Reloading is a science, and improperly loaded ammunition can cause severe damage to the firearm and may result in serious injury or death to the operator and/or others.

Always use ammunition that complies with the industry performance standards established by the Sporting Arms and Ammunition Manufacturers' Institute, Inc. (SAAMI) or ammunition manufactured to U.S. military specifications.

SIG SAUER, Inc., specifically disclaims responsibility for any damage or injury whatsoever occurring in connection with, or as a result of, the use of any SIG SAUER firearm of faulty, nonstandard, hand-loaded (reloaded) ammunition, or cartridges other than those for which the firearm was originally chambered. Excessive pressure inside the chamber or barrel while firing a firearm may cause severe damage and serious injury or death to the shooter or to others may occur.



WARNING: CANCER AND REPRODUCTIVE HARM—www.P65warnings.ca.gov



DISCHARGING FIREARMS IN POORLY VENTILATED AREAS, CLEANING FIREARMS, OR HANDLING AMMUNITION MAY RESULT IN EXPOSURE TO LEAD AND OTHER SUBSTANCES KNOWN TO THE STATE OF CALIFORNIA TO CAUSE BIRTH DEFECTS, REPRODUCTIVE HARM, AND OTHER SERIOUS PHYSICAL INJURY. MAINTAIN ADEQUATE VENTILATION AT ALL TIMES. WASH HANDS THOROUGHLY AFTER EXPOSURE. SHOOTING OR CLEANING FIREARMS MAY EXPOSE OPERATORS TO LEAD.



WARNINGS

SIG SAUER

6.0 LOCKING DEVICES



All SIG SAUER firearms are shipped with a key-operated locking device or a lockable case.

Never install the locking device inside the trigger guard or in any way that makes it possible to pull the trigger! Do not leave the keys in the lock.

All firearm owners are responsible for secure storage of any firearm.

ALWAYS refer to the locking device's manufacturer directions for installation and removal of the device.



7.0 SAFETY INFORMATION

This Operator's Manual is designed to assist you in learning how to use and care for your SIG SAUER® firearm properly.

Only when you are certain that you fully understand this manual and can properly carry out its instructions should you practice loading and firing your firearm with live ammunition. Having a firearm in your possession is a full-time job; you cannot guess and you cannot forget. You must know how to use your firearm safely.

If you have any doubts about your ability to handle or use this firearm safely, you should seek supervised instruction.

The SIG SAUER Academy provides all levels of firearms safety and skill training, from beginner to expert.

For more information contact:



sigsaueracademy.com • (603) 610-3400
Epping, New Hampshire

SAFETY MUST BE THE FIRST AND CONSTANT CONSIDERATION OF EVERY PERSON WHO HANDLES FIREARMS AND AMMUNITION.

For more information about safety, responsible firearms ownership, and shooting sports, contact:
National Rifle Association (NRA) of America
11250 Waples Mill Road, Fairfax, VA 22030-7400 • 1-800-672-3888
nra.com

Contents

1.0 SAFETY WARNINGS	4
2.0 HANDLING	6
2.1 SAFETY MECHANISMS	6
2.1.1 BASIC RULES OF SAFE FIREARMS HANDLING	8
2.2 ABUSIVE HANDLING	10
3.0 ALTERATIONS AND REPLACEMENT PARTS	11
3.1 ACCESSORIES	12
3.1.1 HOLSTERS	12
3.2 TRANSPORTING	13
3.3 STORAGE	13
3.4 CHAMBER SAFETY FLAG	13
3.5 LIABILITY	14
4.0 EYE AND EAR PROTECTION	15
5.0 AMMUNITION	15
6.0 LOCKING DEVICES	17
7.0 SAFETY INFORMATION	18
8.0 MECHANICAL CHARACTERISTICS	23
8.1 DESCRIPTION OF FIREARM	23
8.2 MAIN COMPONENTS AND OPERATOR CONTROLS	24
8.3 PRINCIPAL SAFETY FEATURES	28
9.0 HANDLING	29
9.1 PREPARATION INSTRUCTIONS	29
9.2 MANUAL SAFETY	30
9.3 UNLOADING AND CLEARING THE PISTOL	31
9.4 LOADING THE MAGAZINE	32
9.5 LOADING THE PISTOL	33
9.6 RELOADING DURING SHOOTING – DEPLETED MAGAZINE	36



9.7 RELOADING DURING SHOOTING – PARTIAL MAGAZINE	39
9.8 UNLOADING THE PISTOL (MAGAZINE NOT EMPTY)	41
9.9 UNLOADING THE PISTOL (MAGAZINE EMPTY, SLIDE OPEN)	44
10.0 FIRING	46
11.0 USER-LEVEL AUTHORIZED MAINTENANCE	49
11.1 FIELD STRIP THE PISTOL	49
11.2 CLEANING AND LUBRICATING THE P211 PISTOL	56
11.3 PISTOL ASSEMBLY	60
11.4 COMPENSATOR MAINTENANCE	68
11.4.1 REMOVAL	68
11.4.2 CLEANING	72
11.4.3 INSTALLATION	72
11.5 MAGAZINE MAINTENANCE	75
11.5.1 DISASSEMBLY	75
11.5.2 CLEANING	78
11.5.3 ASSEMBLY	79
12.0 FUNCTION CHECK	83
13.0 PISTOL ADJUSTMENTS	85
13.1 MAGAZINE CATCH	85
13.1.1 REMOVAL	85
13.1.2 INSTALLATION	87
13.2 GRIP PANELS	88
13.2.1 REMOVAL	88
13.2.2 INSTALLATION	89
13.3 MAGAZINE FUNNEL	90
13.3.1 REMOVAL	90
13.3.2 INSTALLATION	91
13.4 LOW PROFILE MAGAZINE WELL	92

13.4.1 REMOVAL	92
13.4.2 INSTALLATION	93
13.5 TRIGGER OVERTRAVEL SCREW	94
14.0 SIGHTS	95
14.1 REAR SIGHT	96
14.1.1 REMOVAL	96
14.1.2 INSTALLATION	97
14.2 OPTIC FILLER PLATE	98
14.2.1 REMOVAL	98
14.2.2 INSTALLATION	99
14.3 SIG-LOC ELECTRO-OPTICS	100
14.3.1 INSTALLATION	100
14.3.2 REMOVAL	102
15.0 STORAGE AND TRANSPORTATION	103
15.1 STORAGE	103
15.2 TRANSPORTATION	104
16.0 REPLACEMENT PARTS POLICY	105
17.0 TROUBLESHOOTING GUIDE	107
17.1 STOPPAGES	107
17.2 OBSTRUCTED BORE	108
17.3 COOK-OFF	109
17.4 GENERAL STOPPAGES	110
17.5 MINIMIZING STOPPAGES	111
18.0 FACTORY REPAIR OF THE FIREARM	112
18.1 RETURNING FIREARMS FOR REPAIR	113
19.0 PARTS DIAGRAMS	114
19.1 STANDARD SLIDE PARTS	114



19.2 STANDARD FRAME PARTS	115
19.3 GT5 SLIDE PARTS	116
19.3.1 GT4 SLIDE PARTS	117
19.3.2 GT4 FRAME PARTS	118
SIG SAUER INFINITE GUARANTEE™	119

8.0 MECHANICAL CHARACTERISTICS

8.1 DESCRIPTION OF FIREARM

The SIG SAUER P211® pistol is a modern pistol designed from the foundation of the classic 1911 and adapted to accommodate a double stack magazine. The P211 is a hammer fired, mechanically locked, short-recoil operated pistol with semi-automatic reloading. Firing takes place with each pull of the trigger. The slide locks open on the magazine follower after the last cartridge has been fired.

Additional information about SIG SAUER products, SIG SAUER Academy and the SIG Experience Center, Special Programs, and additional support can be found by scanning the QR code below to visit sigsauer.com.





8.2 MAIN COMPONENTS AND OPERATOR CONTROLS

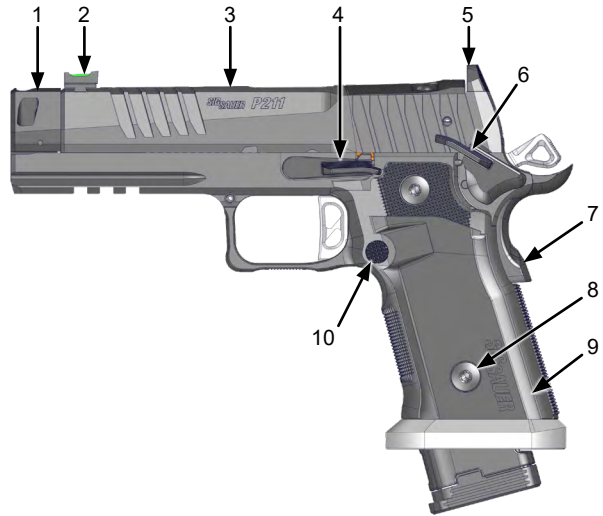

OPERATOR CONTROLS AND FEATURES

1	Compensator	A muzzle device for mitigating felt recoil.
2	Front Sight	A visual aid for proper alignment of the pistol.
3	Slide	Chambers and extracts rounds, provides a locking mechanism, houses firing and safety components, and manages recoil.
4	Slide Catch Lever	Secures the slide and barrel to the frame, holds and releases the slide, and aids in reloading. Can be used to manually lock slide to rear.
5	Rear Sight	A visual aid for proper alignment of the pistol.
6	Manual Safety Lever	Blocks trigger movement and locks the slide in the forward position.
7	Grip Safety	When engaged, blocks motion of the trigger that would otherwise discharge the firearm.
8	Grip Screw	Secures the grip panel to the grip.
9	Grip Panel	A surface for gripping the firearm.
10	Magazine Catch	Holds and releases the magazine in the frame.

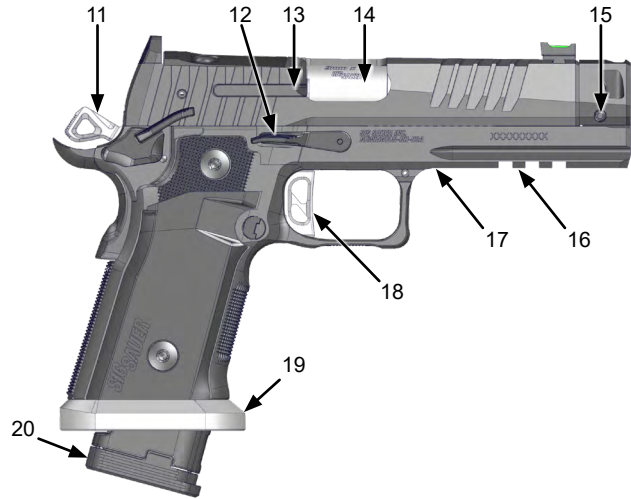
**OPERATOR CONTROLS AND FEATURES**

11	Hammer	Strikes the firing pin when the trigger is pulled, firing the cartridge.
12	Ambidextrous Slide Catch Lever	Holds and releases the slide and aids in reloading. Can be used to manually lock slide to rear for maintenance.
13	Extractor	Pulls spent casings or cartridges out of the chamber.
14	Barrel	Guides the projectile from the chamber to the muzzle when the pistol is fired.
15	Compensator Set Screw	Aids in attaching the compensator to the barrel.
16	Accessory Rail	Provides a mounting platform for accessories and attachments.
17	Frame	Houses firing and safety components and the magazine.
18	Trigger	When pulled, actuates the internal components to release the hammer.
19	Magazine Well	Extends the magazine well to provide ease of reloading.
20	Magazine	Holds and positions cartridges in place for feeding.



8.3 PRINCIPAL SAFETY FEATURES

The P211 incorporates multiple safety features including the grip safety, ambidextrous manual safety, and firing pin safety lock.

- The manual safety, when engaged, blocks the movement of the trigger, preventing accidental discharge.
- The grip safety acts as a secondary safety to prevent accidental discharge.
- The firing pin safety lock prevents the firing pin from striking the cartridge unless the trigger is pulled.
- The disconnecter prevents the trigger from releasing the hammer when the slide is pulled back.

9.0 HANDLING

9.1 PREPARATION INSTRUCTIONS



WARNING



PRIOR TO PERFORMING ANY MAINTENANCE ON THE FIREARM, READ AND UNDERSTAND THE OPERATOR'S MANUAL. ENSURE THAT THE FIREARM IS UNLOADED, CLEARED, AND THE MAGAZINE IS REMOVED. SAFETY GLASSES SHOULD BE WORN WHENEVER DISASSEMBLING, CLEANING, INSPECTING, OR ASSEMBLING A FIREARM. FAILURE TO COMPLY MAY RESULT IN SERIOUS INJURY OR DEATH TO THE USER OR BYSTANDERS.

Prior to using the firearm, read, understand, and follow all the safety warnings in the Safety Warnings Manual included with the firearm.

- Perform an initial field strip (*11.1 Field Strip the Pistol on page 49*).
- Clean any fouling that might have occurred during factory testing (*11.2 Cleaning and lubricating the P211 Pistol on page 56*).
- Inspect, lubricate, and reassemble the firearm (*11.3 Pistol Assembly on page 60*).
- Upon reassembly and prior to firing the firearm, conduct a function check (*12.0 Function Check on page 83*). If the firearm does not complete the function check as described, contact customer service (*16.0 Replacement Parts Policy on page 105*).

Any maintenance beyond the user level described in this manual is to be performed by a certified SIG SAUER Armorer specifically trained on the maintenance of the P211.



9.2 MANUAL SAFETY

The SIG SAUER P211 is equipped with a manual safety lever. When engaged, the manual safety mechanically blocks the movement of the sear, preventing release of the hammer.

To engage the manual safety, rotate the safety lever upward. The slide cannot move when the manual safety is engaged. To disengage, rotate the safety lever downward. Moving the safety lever on either side automatically moves the lever on the opposite side.



MANUAL SAFETY DISENGAGED (LEFT SIDE)



MANUAL SAFETY ENGAGED (LEFT SIDE)

9.3 UNLOADING AND CLEARING THE PISTOL

When there is a live cartridge in the chamber, the cartridge will discharge if the safeties are disengaged and the trigger is pulled. It is absolutely essential to completely unload and clear the pistol when it is not in use.



WARNING UNLOAD/CLEAR



FAILURE TO ENSURE THE FIREARM IS UNLOADED AND CLEARED COULD RESULT IN UNINTENTIONAL DISCHARGE, CAUSING SERIOUS INJURY, DEATH, OR PROPERTY DAMAGE. REMOVING THE MAGAZINE FROM THE FIREARM DOES NOT PREVENT A CHAMBERED ROUND FROM BEING FIRED.

1. Point the muzzle in a safe direction.
2. Release the magazine.
3. Lock the slide rearward to open the chamber.
4. Visually verify that chamber and barrel are clear of any cartridges.
5. Check the firearm twice, both visually and physically.
6. Release the slide forward and engage the manual safety.



9.4 LOADING THE MAGAZINE

CAUTION

ENSURE THAT THE MAGAZINE IS THE PROPER TYPE AND CALIBER FOR THE PISTOL.

NOTE

Do not attempt to insert more cartridges than the magazine's designed capacity.

1. Using the rim of the cartridge case, push down on the magazine follower. Ensure that the projectile is facing the front of the magazine.
2. Push the cartridge to the rear of the magazine and under the magazine lips.



3. Repeat until the magazine holds the desired number of cartridges or is full.

9.5 LOADING THE PISTOL

1. Point the pistol in a safe direction.
2. While pressing up on the slide catch lever, retract the slide until the lever rotates up into the slide catch notch in the slide, locking the slide in place.

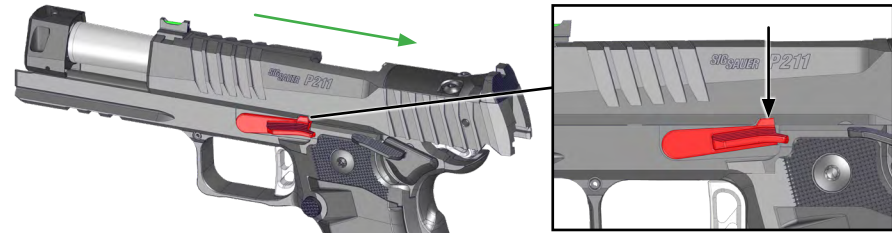

3. Visually and physically inspect the chamber and breech face to ensure that it is clear of any debris.

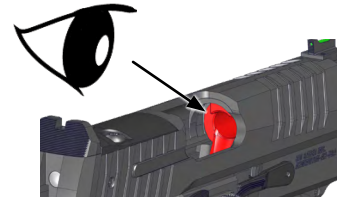



4. Insert a loaded magazine into the grip until it locks in place. There should be an audible click.



5. Chamber a cartridge by releasing the slide, either by:
- Pressing down on the slide catch lever.
 - Pulling back on the slide, then releasing. Do not ride the slide forward. Failure to properly complete this step may induce a stoppage.

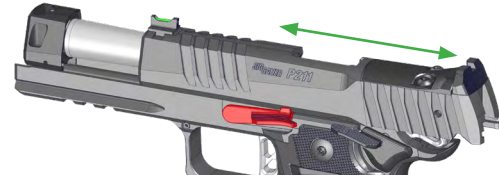

WARNING LOADED PISTOL



THE PISTOL IS NOW LOADED AND READY TO FIRE

6. Engage the manual safety.

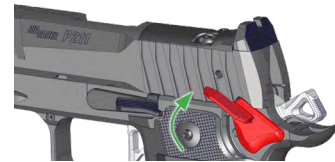



9.6 RELOADING DURING SHOOTING – DEPLETED MAGAZINE

When the last cartridge in the magazine is expended, the slide will be locked back in the open position by the slide catch lever.

1. Keep the muzzle pointed in a safe direction
2. Press the magazine catch to remove the empty magazine.



3. Insert a loaded magazine, pushing it up into grip until it locks in place. There should be an audible click.



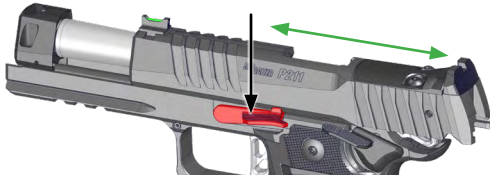

4. Chamber a cartridge by releasing the slide, either by:
 - a. Pressing down on the slide catch lever.
 - b. Pulling back on the slide, then releasing. Do not ride the slide forward. Failure to properly complete this step may induce a stoppage.

**WARNING LOADED PISTOL****THE PISTOL IS NOW LOADED AND READY TO FIRE**

5. Engage the manual safety.

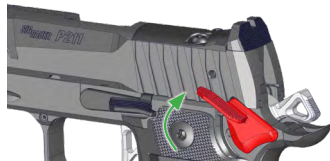
**9.7 RELOADING DURING SHOOTING – PARTIAL MAGAZINE**

1. Keep the muzzle pointed in a safe direction and engage the manual safety.
2. Press the magazine catch to remove the partially loaded magazine.

**WARNING LOADED PISTOL****THE PISTOL STILL HAS A LIVE CARTRIDGE CHAMBERED AND CAN BE FIRED IF THE MANUAL SAFETY IS DISENGAGED AND THE TRIGGER IS PULLED.**



3. Insert a loaded magazine by pushing it up and into the magazine well until it locks in place. There should be an audible click.

**WARNING LOADED PISTOL****THE PISTOL IS NOW LOADED AND READY TO FIRE**

9.8 UNLOADING THE PISTOL (MAGAZINE NOT EMPTY)

1. Keep the muzzle pointed in a safe direction and engage the manual safety.
2. Press the magazine catch and remove the magazine.

**WARNING LOADED PISTOL****THE PISTOL STILL HAS A LIVE CARTRIDGE CHAMBERED AND CAN BE FIRED IF THE MANUAL SAFETY IS DISENGAGED AND THE TRIGGER IS PULLED.**



3. Press down on the manual safety lever to disengage the manual safety.
4. Pull the slide completely to the rear while watching for the ejection of a live cartridge. Push up on the slide catch lever to lock the slide open.



5. Visually and physically check the chamber, magazine well, and breech face to ensure that the pistol is completely free of ammunition.

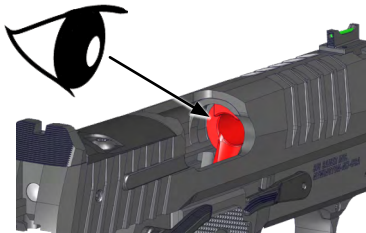

6. Press down on the slide catch lever to release the slide forward.



7. Engage the manual safety.





9.9 UNLOADING THE PISTOL (MAGAZINE EMPTY, SLIDE OPEN)

1. Keep the muzzle pointed in a safe direction.
2. Press the magazine catch and remove the magazine.
3. Visually and physically check the chamber to ensure that pistol is completely free of ammunition.

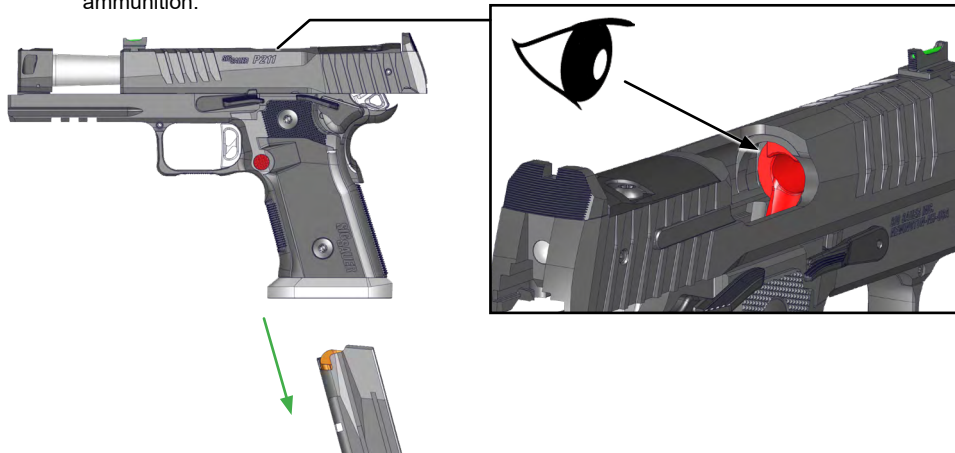

4. Press down on the slide catch lever to release the slide forward.



5. Engage the manual safety.





10.0 FIRING



WARNING LOADED PISTOL



KEEP FINGERS OUT OF TRIGGER GUARD AND OFF THE TRIGGER UNTIL READY TO FIRE. ALWAYS ENSURE FIREARM IS POINTED IN A SAFE DIRECTION. FAILURE TO COMPLY MAY RESULT IN SERIOUS INJURY OR DEATH.



WARNING BARREL

BEFORE LOADING, ALWAYS CLEAN ALL GREASE AND OIL FROM THE BORE AND CHAMBER AND VERIFY THAT NO OBSTRUCTION IS IN THE BARREL. ANY FOREIGN MATTER IN THE BARREL COULD RESULT IN A BULGED OR BURST BARREL OR OTHER DAMAGE TO THE FIREARM AND COULD CAUSE SERIOUS INJURY.



WARNING SAFETY



THE PISTOL SLIDE OPENS AND SHUTS QUICKLY WHILE FIRING. KEEP FACE AND HANDS AWAY FROM IT. HOT BRASS AND POWDER GAS IS EJECTED QUICKLY AND CAN BURN THE USER OR OTHERS NEARBY. ALWAYS WEAR SAFETY GLASSES AND HEARING PROTECTION TO PREVENT INJURY. NEVER ALLOW OTHERS TO STAND WHERE THEY MAY BE STRUCK BY AN EJECTED CARTRIDGE CASE.

1. Aim the pistol at a safe target and grip the pistol securely to disengage the grip safety.

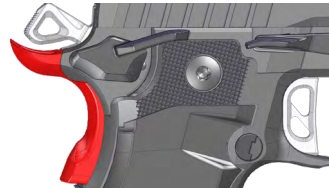

ENGAGED

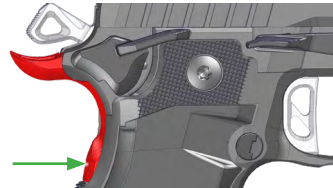

DISENGAGED

2. Press down on the manual safety lever to disengage the manual safety.
3. Pull the trigger to fire.
4. Keep the pistol aimed downrange or at a safe target until done shooting.



**WARNING SAFETY**

DO NOT ATTEMPT TO LOWER THE HAMMER OF THIS PISTOL BY PRESSING THE TRIGGER AND EASING THE HAMMER FORWARD. MANUALLY LOWERING THE HAMMER IN THIS MANNER PREVENTS THE FULL APPLICATION OF THE SAFETY FEATURES OF THIS PISTOL. FAILURE TO COMPLY WITH THIS WARNING COULD CAUSE AN UNINTENTIONAL DISCHARGE RESULTING IN DEATH, SERIOUS INJURY, OR DAMAGE TO PROPERTY.

5. When finished shooting, press up on the manual safety lever to engage the manual safety.

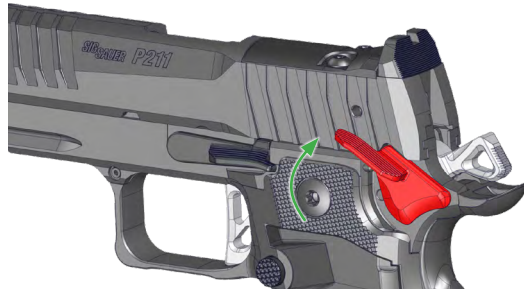
**11.0 USER-LEVEL AUTHORIZED MAINTENANCE****WARNING UNLOAD/CLEAR**

FAILURE TO ENSURE THE FIREARM IS UNLOADED AND CLEARED COULD RESULT IN UNINTENTIONAL DISCHARGE, CAUSING SERIOUS INJURY, DEATH, OR PROPERTY DAMAGE. REMOVING THE MAGAZINE FROM THE FIREARM DOES NOT PREVENT A CHAMBERED ROUND FROM BEING FIRED.

CAUTION

DO NOT ATTEMPT TO DISASSEMBLE A SIG SAUER FIREARM BEYOND THE POINT EXPLAINED IN THE OPERATOR'S MANUAL. DISASSEMBLY BEYOND THE INSTRUCTIONS IN THE OPERATOR'S MANUAL IS RESTRICTED TO A CERTIFIED SIG SAUER ARMORER. FAILURE TO COMPLY WITH THESE RESTRICTIONS WILL VOID THE WARRANTY.

11.1 FIELD STRIP THE PISTOL

1. Unload and clear the pistol. See 9.3 *Unloading and Clearing the Pistol* on page 31.
2. Ensure that the hammer is cocked.
3. Disengage the manual safety.

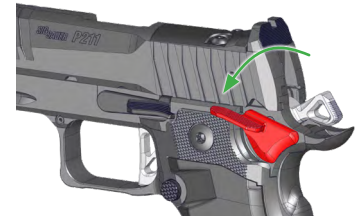



4. Pull the slide to the rear and align the lug of the slide catch lever with the disassembly notch on the slide.

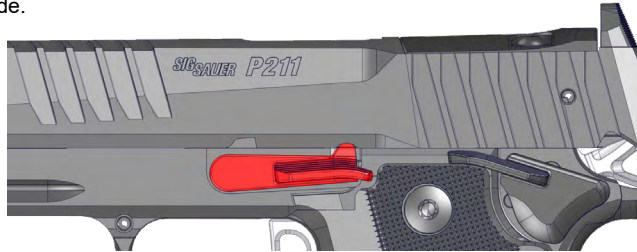

5. Insert a 1/16th-in. pin punch through the right side of the slide catch lever and push the slide catch lever out of the frame from right to left.

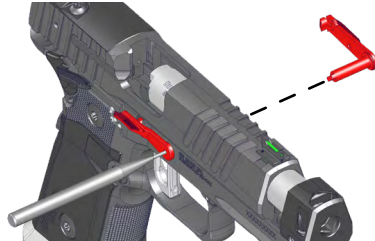
**WARNING PARTS UNDER SPRING TENSION**

FIREARMS CONTAIN SEVERAL SPRING LOADED PARTS. WEAR EYE PROTECTION AND MAINTAIN CONTROL DURING MAINTENANCE. FAILURE TO COMPLY MAY RESULT IN INJURY.

6. Pull the slide assembly forward off of the frame while maintaining grip on the spring guide.

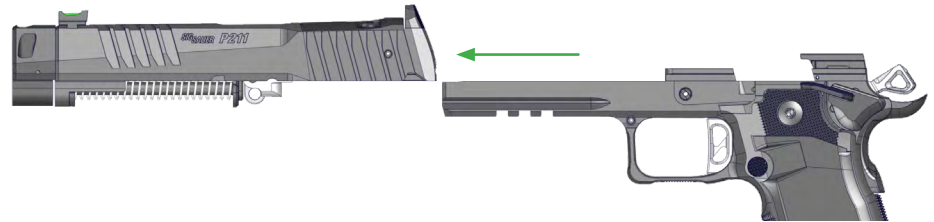
**CAUTION**

DO NOT DRY FIRE THE PISTOL WITH THE SLIDE REMOVED. FAILURE TO COMPLY WILL DAMAGE THE REAR OF THE FRAME.



CAUTION

DO NOT REMOVE THE SLIDE CATCH PIN. FAILURE TO COMPLY MAY RESULT IN DAMAGE TO THE FIREARM.

7. **Optional:** Rotate the ambidexterous slide catch lever clockwise approximately 50 degrees, then remove it from the frame. Ensure that the slide catch pin does not fall out.

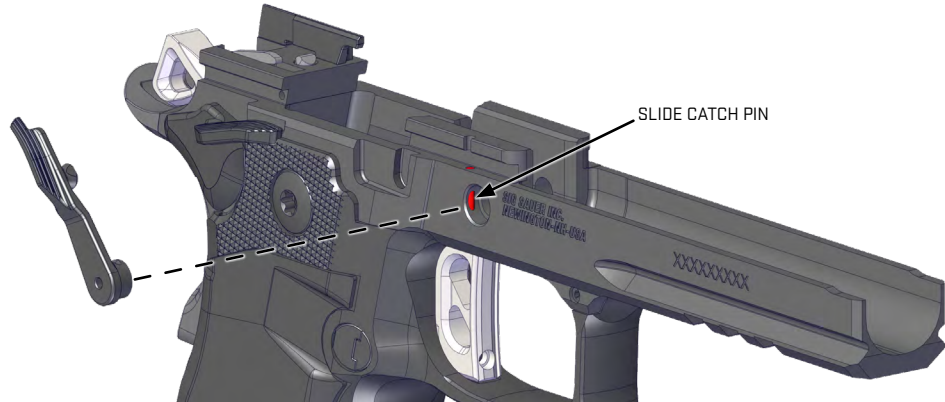

WARNING PARTS UNDER SPRING TENSION



FIREARMS CONTAIN SEVERAL SPRING LOADED PARTS. WEAR EYE PROTECTION AND MAINTAIN CONTROL DURING MAINTENANCE. FAILURE TO COMPLY MAY RESULT IN INJURY.

8. Push the recoil spring and spring guide forward slightly, then lift them up and over the barrel link.

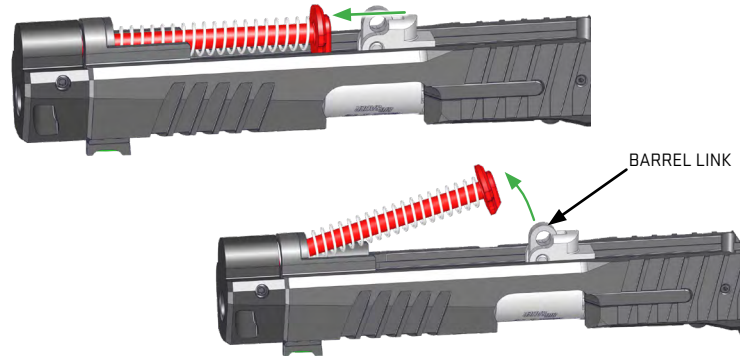



9. Remove the recoil spring from the guide rod.

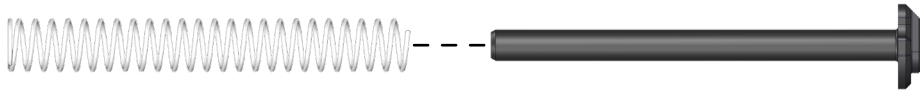

10. Remove the recoil plug from the slide and rotate the barrel link forward.

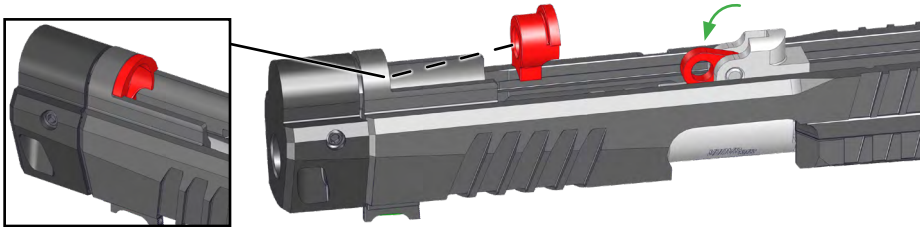

11. Remove the barrel from the front of the slide.

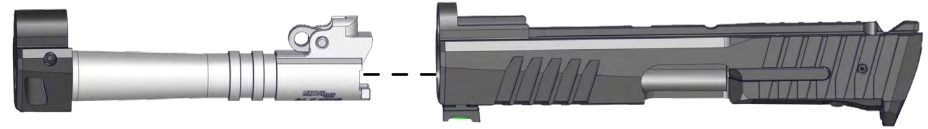

CAUTION

THIS LEVEL OF DISASSEMBLY IS SUFFICIENT TO ALLOW A THOROUGH CLEANING AFTER FIRING. FURTHER DISASSEMBLY IS NOT AUTHORIZED.



11.2 CLEANING AND LUBRICATING THE P211 PISTOL



WARNING CLEANING



READ AND FOLLOW THE MANUFACTURER'S WARNINGS BEFORE USING SOLVENTS OR CLEANERS. USE IN A WELL-VENTILATED AREA. WEAR EYE PROTECTION.

CAUTION

NEVER CLEAN THE BARREL FROM THE MUZZLE END. DO NOT USE A STEEL WIRE BRUSH AS IT CAN DAMAGE THE SMOOTH SURFACE OF THE BARREL. USE A SUITABLE CLEANING ROD AND BRONZE BRUSH OF THE CORRECT CALIBER. SOLVENTS CAN BE HARMFUL TO THE SURFACE FINISH OF THE PISTOL. AVOID OVER-LUBRICATION OF COMPONENTS.

MATERIALS REQUIRED

- Cleaning patches
- Clean cloth
- Bore brush of the proper caliber
- Cleaning rod
- CLP (Cleaning, Lubricant, Preservative)
- Lubricant, low temperature when applicable
- Cleaning brush

The following instructions are for normal environmental conditions. Clean and lube at a minimum of every 500 cartridges.

SLIDE ASSEMBLY

CAUTION

DO NOT LUBRICATE THE FIRING PIN OR FIRING PIN SAFETY LOCK. DO NOT ALLOW LUBRICANT TO FLOW INTO THE FIRING PIN OR FIRING PIN SAFETY LOCK CHANNEL OF THE SLIDE. THIS MAY CAUSE A LIGHT STRIKE TO THE CARTRIDGE, RESULTING IN A FAILURE TO FIRE.

1. Remove all of the old lubricant before applying any new lubricant.
2. Clean the slide assembly with a cloth. A soft brush and CLP can be used to clean excessive dirt and carbon buildup. Ensure the extractor, rail slots, and breech face are free of dirt and residue.
3. Apply a light coat of CLP to the frame rail slots of the slide.
4. Lightly oil all external parts.
5. Do not lubricate the firing pin hole or the firing pin safety lock.

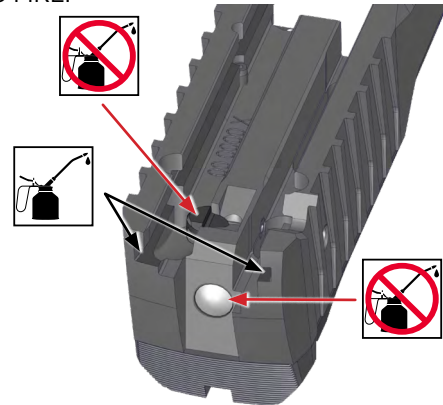

**FRAME ASSEMBLY****CAUTION**

DURING CLEANING, INSPECT UNDER THE FRONT RIGHT FRAME RAIL FOR THE SLIDE CATCH PIN. IF THE SLIDE CATCH PIN IS NOT PRESENT, CONTACT SIG SAUER CUSTOMER SERVICE.

1. Wipe the frame assembly with a soft cloth.
2. Use cotton swabs to clean hard to reach areas. Pay special attention to the frame rails.
3. Lubricate the frame rails with a light coat of CLP.
4. Apply CLP to accessible functioning parts.
5. Clean the magazine well of any dirt, dust, or residue with a soft cloth.

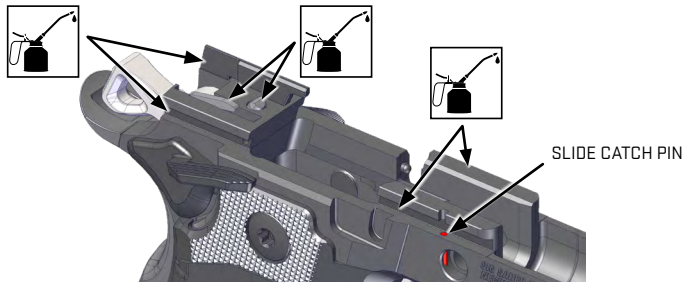
**BARREL**

1. Soak a patch with CLP and push it through the bore from the chamber end and out past the muzzle.
2. Allow the CLP to soak for a while to loosen residue and soften carbon deposits.
3. Wipe the exterior of the barrel with a cloth soaked in CLP.
4. Repeat step #1.
5. Use the bore brush and a cleaning rod to scrub heavy deposits from the bore.
6. Repeat step #1.
7. Push dry patches through the bore until they come out clean.
8. Lightly oil bore and chamber if the pistol is to be stored for a period of time.
9. Always remove any lubricant from the bore prior to firing the pistol.

RECOIL SPRING AND GUIDE ASSEMBLY

1. Clean the recoil spring guide assembly with CLP and a soft brush.
2. Clean recoil spring with a soft cloth lightly coated in CLP.
3. After cleaning, apply a light coat of CLP.



11.3 PISTOL ASSEMBLY

1. Verify that the pistol is clear of all foreign matter.
2. Ensure that the barrel link is rotated forward and insert the barrel into the slide.

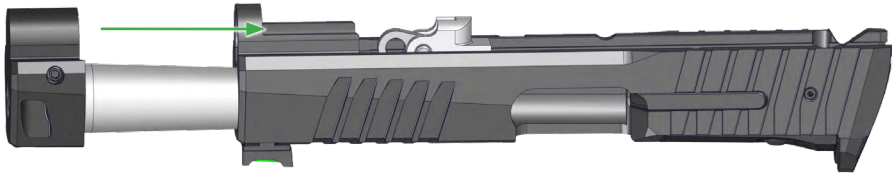

3. Insert the recoil spring guide into the recoil spring, open end first.

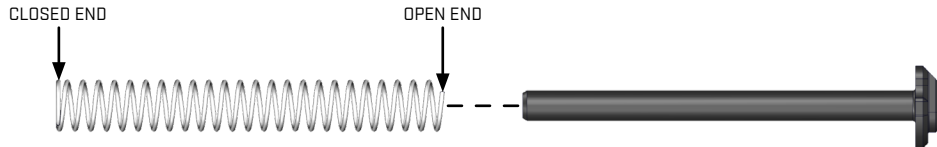

4. Install the recoil plug and rotate the barrel link up.

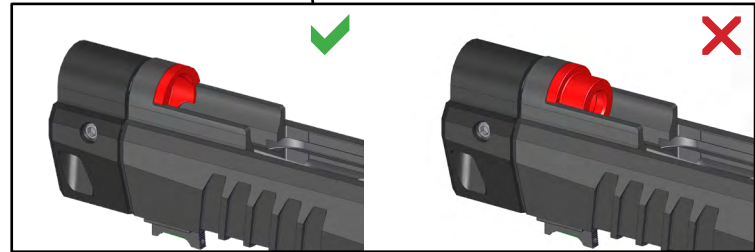
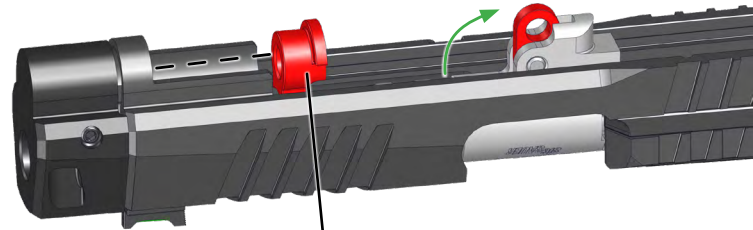

**WARNING PARTS UNDER SPRING TENSION**

FIREARMS CONTAIN SEVERAL SPRING-LOADED PARTS. WEAR EYE PROTECTION AND MAINTAIN CONTROL DURING MAINTENANCE. FAILURE TO COMPLY MAY RESULT IN INJURY.

5. Install the recoil spring and guide into the slide with the flat portion against the barrel.

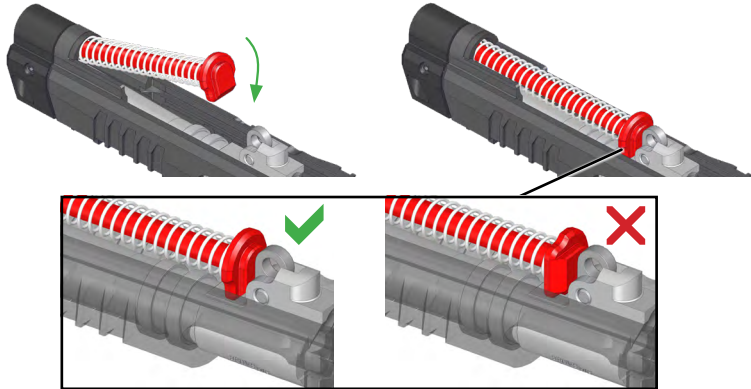
**CAUTION**

DO NOT DRY FIRE WITHOUT THE SLIDE INSTALLED. FAILURE TO COMPLY MAY CAUSE DAMAGE TO THE FRAME.

6. Ensure that the hammer is still cocked.



7. Insert the ambidextrous slide catch lever into the frame at a 50 degree angle and rotate it down into its retaining notch.

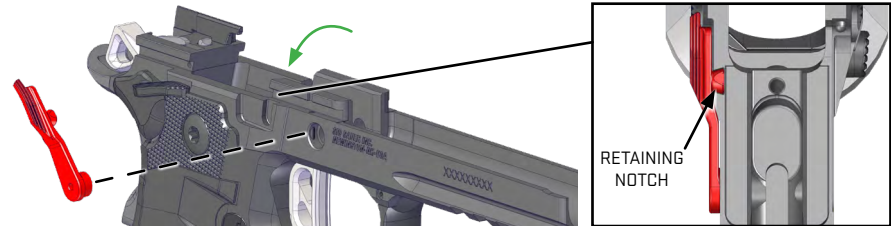



8. Ensure the firing pin safety lever is down.

FIRING PIN SAFETY LEVER

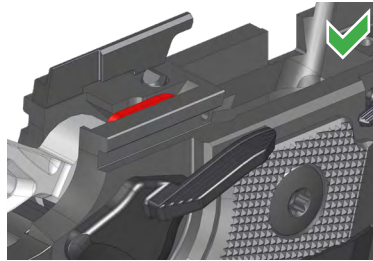
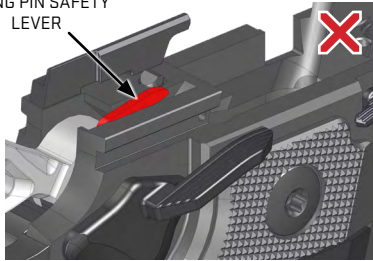

9. Align the rails on the frame with the slots on the side and push the slide onto the frame.

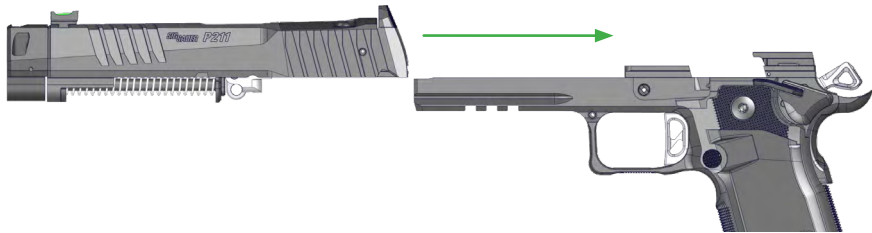

10. Push the slide to the rear until the barrel link is aligned with the slide catch hole on the left side of the frame. Hold the slide here for the following steps.

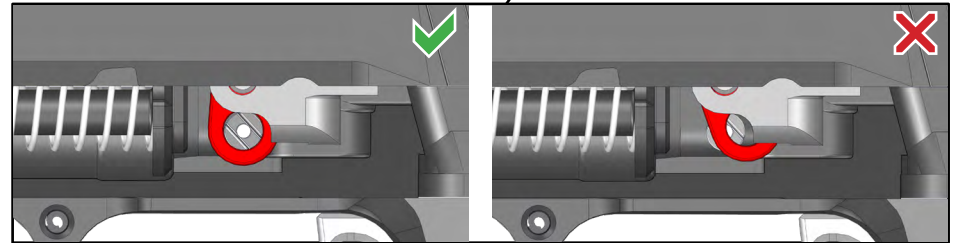



11. Insert the slide catch lever partway through the frame so it passes through the barrel link.



12. Align the disassembly notch on the slide and push the slide catch lever the rest of the way into the frame.

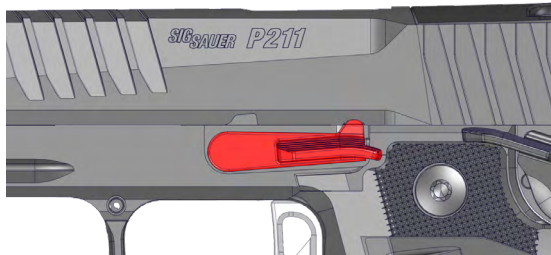

13. Allow the slide to travel forward and engage the manual safety.





11.4 COMPENSATOR MAINTENANCE

11.4.1 REMOVAL



WARNING PARTS UNDER SPRING TENSION



FIREARMS CONTAIN SEVERAL SPRING LOADED PARTS. WEAR EYE PROTECTION AND MAINTAIN CONTROL DURING MAINTENANCE. FAILURE TO COMPLY MAY RESULT IN INJURY.

CAUTION

THE COMPENSATOR SET SCREW SHOULD BE TIGHTENED TO 15 IN-LBF. INSPECT THE COMPENSATOR SET SCREW FOR TIGHTNESS EVERY 1000 ROUNDS FIRED. FAILURE TO COMPLY MAY RESULT IN DAMAGE TO THE COMPENSATOR AND BARREL.

NOTE

Removing the compensator is not required for normal preventive maintenance of the pistol. Compensator removal and replacement should only be performed should the compensator need cleaning or require maintenance.

1. Field strip the pistol. See *11.1 Field Strip the Pistol* on page 49.

2. Using a 5/64-in. hex drive bit, unscrew the set screw on the right side of the compensator and remove it and the compensator detent spring.

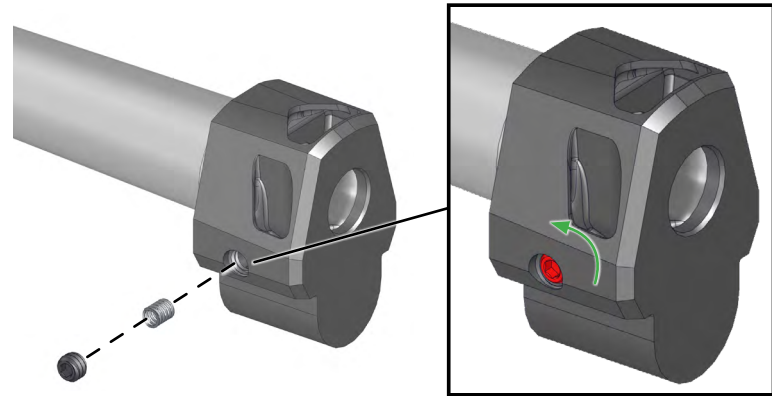



CAUTION

DO NOT UNDER ANY CIRCUMSTANCES ATTEMPT TO FORCEFULLY DRIVE THE DETENT OUT OF THE COMPENSATOR. FAILURE TO COMPLY WILL DAMAGE THE BARREL.

3. Insert a 1/16th-in. punch in the small hole on the left side of the compensator and press on the detent to remove it. Do not hammer the punch or use excessive force. Do not drive the punch into the barrel lug.
 - If the detent does not fall out freely, it may be necessary to gently tap the punch with a gunsmith's hammer. If the detent still can not be removed, do not attempt to strike the punch with more force. Contact SIG SAUER Customer Service.

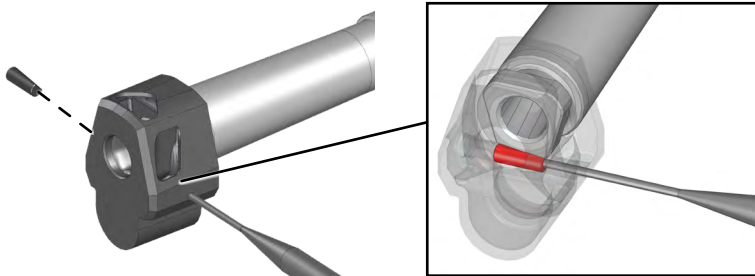

4. Rotate the compensator and remove it from the front of the barrel.

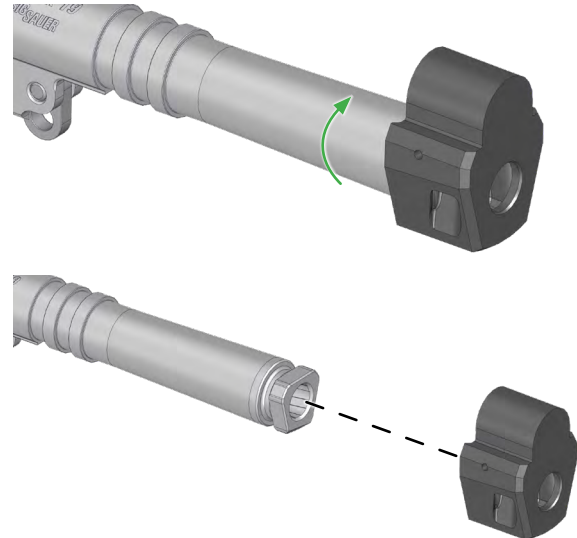



11.4.2 CLEANING

- Using a nylon brush, clean any carbon buildup from all accessible surfaces.
- Clean the compensator detent hole of carbon buildup and ensure that it is dry and clear of any debris.

11.4.3 INSTALLATION

1. Align the lugs on the barrel with the slot in the compensator. Install the compensator on the barrel upside-down, then rotate it into position.

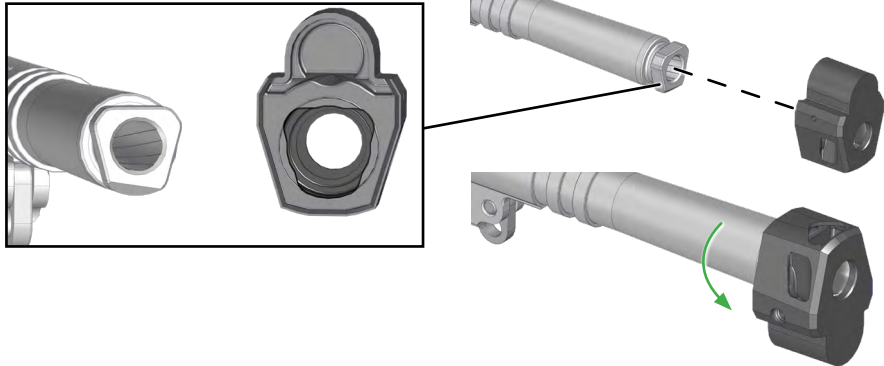

2. Install the detent with the angled surface facing diagonally up and toward the barrel. Press the detent with a punch to ensure that it seats against the barrel. The compensator must not rotate.

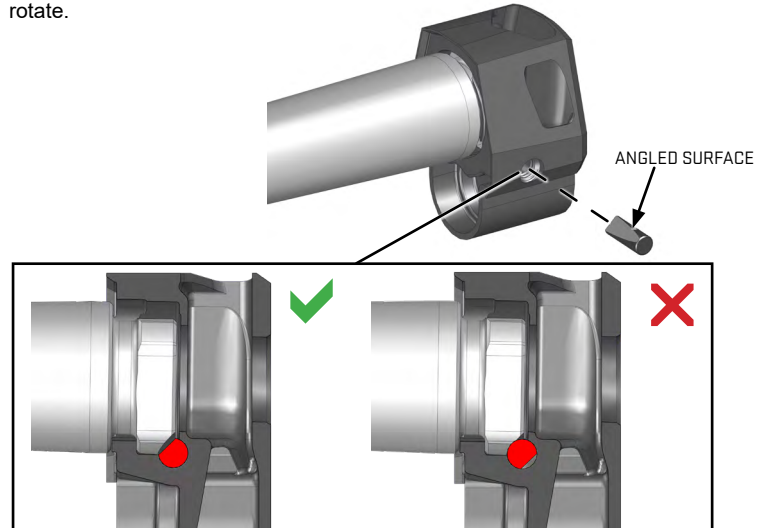



3. Install the compensator detent spring and compensator set screw. Using a 5/64-in. hex drive bit, tighten the screw to 15 in-lbf.

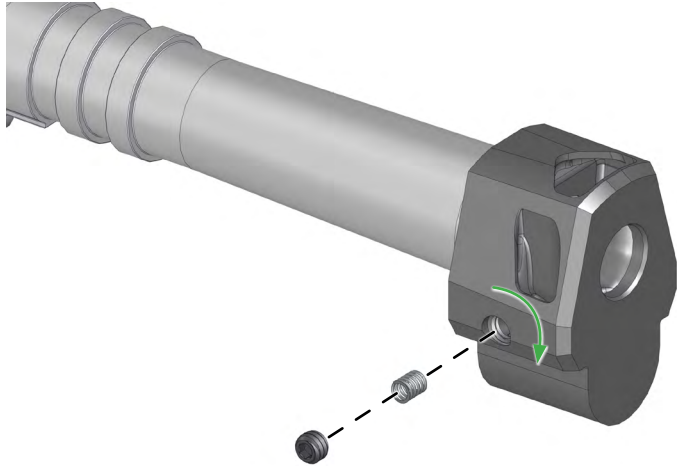

11.5 MAGAZINE MAINTENANCE

11.5.1 DISASSEMBLY

21-ROUND MAGAZINES



WARNING PARTS UNDER SPRING TENSION



FIREARMS CONTAIN SEVERAL-SPRING LOADED PARTS. WEAR EYE PROTECTION AND MAINTAIN CONTROL DURING MAINTENANCE. FAILURE TO COMPLY MAY RESULT IN INJURY.

1. Using a punch or similar tool, push the tab of the magazine insert forward then down to release and remove the floorplate.

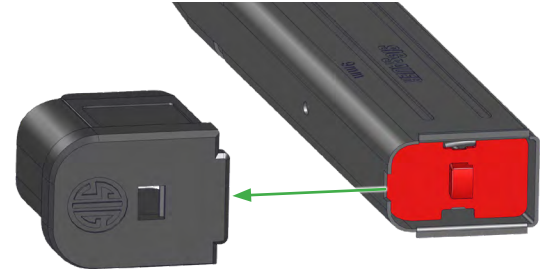



2. Remove the magazine follower and magazine spring from the magazine tube.

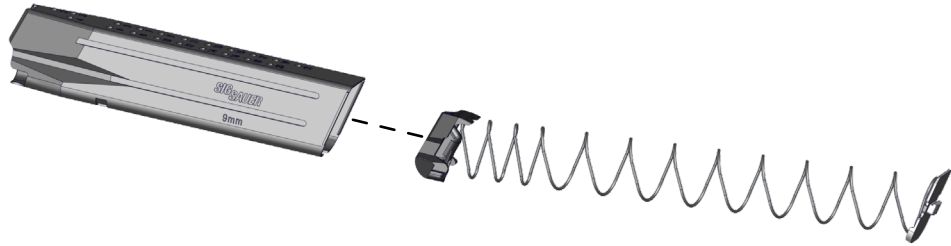

23-ROUND MAGAZINES

1. Press the two magazine sleeve tabs in the magazine floorplate toward each other and slide the sleeve up and off of the magazine tube.

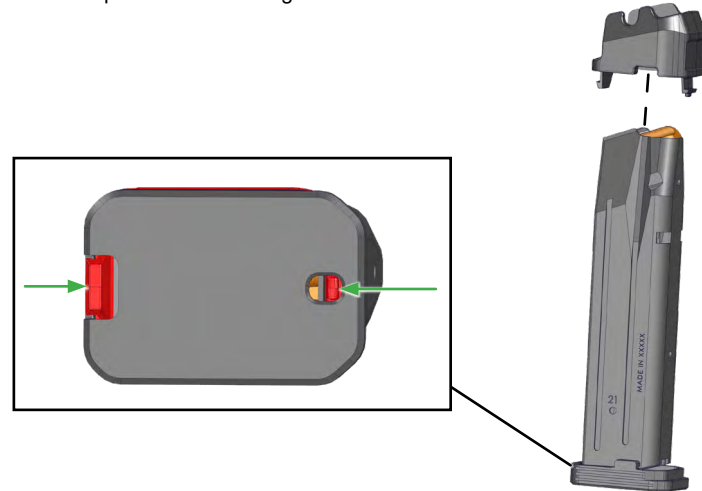



2. Cup a hand under the bottom of the magazine tube to control the magazine spring and slide the floorplate off of the magazine tube.
3. Remove the magazine follower and magazine spring from the magazine tube.



11.5.2 CLEANING

1. Wipe the magazine tube and follower with a cloth. Clean the magazine tube and follower with a soft brush and CLP.
2. Use a cloth to clean the magazine spring, base plate, floorplate, and magazine sleeve (if applicable).
3. Apply a light coat of CLP to the spring and magazine tube.

11.5.3 ASSEMBLY

21-ROUND MAGAZINES

1. Place the magazine follower on the magazine spring and insert it into the bottom of the magazine tube.



WARNING PARTS UNDER SPRING TENSION



FIREARMS CONTAIN SEVERAL SPRING-LOADED PARTS. WEAR EYE PROTECTION AND MAINTAIN CONTROL DURING MAINTENANCE. FAILURE TO COMPLY MAY RESULT IN INJURY.

2. Compress the magazine spring fully into magazine tube until the magazine insert is flush with the bottom of the magazine tube.





3. Holding the magazine insert in place, slide the magazine floorplate onto the magazine tube lips until the floorplate is locked in place by the insert.



23-ROUND MAGAZINES

1. Slide the magazine follower and magazine spring up into the magazine tube.
2. Slide the magazine floorplate onto the bottom of the magazine to retain the spring.

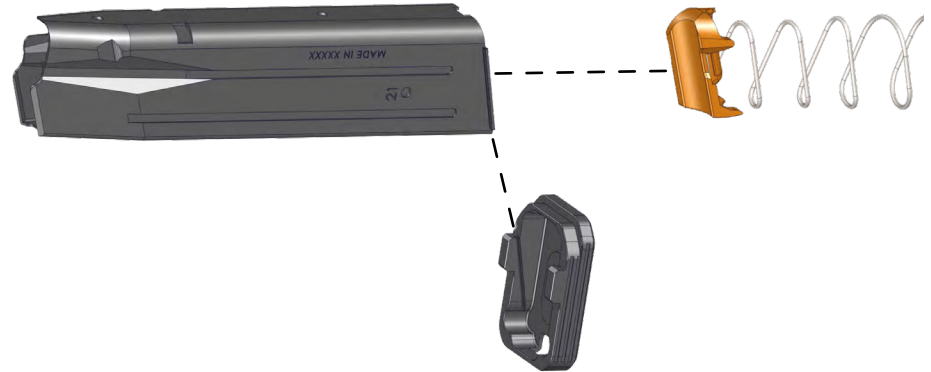



- Slide the magazine sleeve down the magazine tube until it locks into the floorplate. There will be a light click.

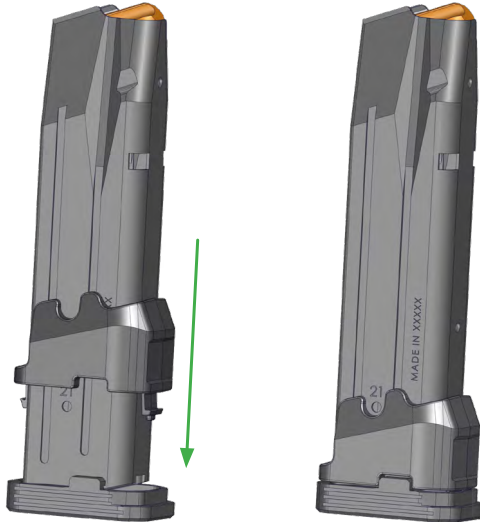

12.0 FUNCTION CHECK

The function check is performed on the assembled pistol to verify functionality. It should be performed after the completion of repairs and after each time the pistol is cleaned and reassembled.



WARNING UNLOAD/CLEAR



FAILURE TO ENSURE THE FIREARM IS UNLOADED AND CLEARED COULD RESULT IN UNINTENTIONAL DISCHARGE, CAUSING SERIOUS INJURY, DEATH, OR PROPERTY DAMAGE. REMOVING THE MAGAZINE FROM THE FIREARM DOES NOT PREVENT A CHAMBERED ROUND FROM BEING FIRED.

IF THE FIREARM FAILS TO COMPLETE THE FUNCTION CHECK, DO NOT USE THE FIREARM. CONTACT CUSTOMER SERVICE.

- Ensure the magazine is removed and the pistol is unloaded and cleared. See *9.3 Unloading and Clearing the Pistol* on page 31.
- Insert an empty magazine into the magazine well. There should be an audible click. The magazine catch must hold the magazine in place.
- Grasp slide and pull it completely to the rear. The magazine follower should push up the slide catch lever, locking the slide to the rear.
- Press the magazine catch. The magazine must fall free under its own weight.
- Press the slide catch lever to release the slide to the forward locked position.
- Engage the manual safety.



7. Point the pistol in a safe direction, compress the grip safety, and pull the trigger. Hammer must not fall.
8. Disengage the manual safety.
9. Compress the grip safety and pull and hold the trigger to the rear. Hammer must fall.
10. While holding the trigger, pull the slide completely to the rear, then release. Hammer should stay cocked. Release trigger.
11. Grip the pistol without compressing the grip safety.
12. Point the pistol in a safe direction and pull the trigger. The trigger's rearward movement must be blocked and the hammer must not fall.
13. Grip the pistol and compress the grip safety.
14. Pull the trigger. Hammer must fall.

CAUTION

NEVER USE A FIREARM OR MAGAZINE THAT SHOWS SIGNS OF DAMAGE OR FAILS A FUNCTION CHECK. VERIFY THE MAGAZINE IS THE CORRECT MODEL AND CALIBER FOR THE PISTOL. IF THE CONDITION OR FUNCTION OF THE PISTOL OR MAGAZINE IS SUSPECT, RETURN THE PISTOL OR MAGAZINE TO SIG SAUER FOR EVALUATION.

13.0 PISTOL ADJUSTMENTS

13.1 MAGAZINE CATCH

13.1.1 REMOVAL

1. Ensure that the magazine is removed and the pistol is unloaded and cleared. See 9.3 *Unloading and Clearing the Pistol on page 31*.
2. Press and hold the magazine catch until the opposite side of the button protrudes from the other side of the grip. The hole in the magazine catch should be visible.

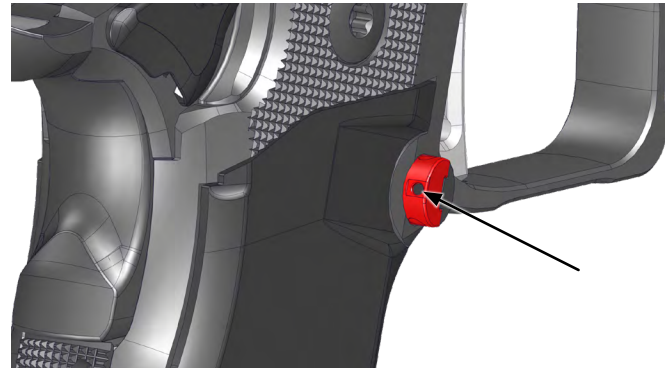



3. Press the end of a small round pin, such as a paper clip, into the hole of the magazine catch button. Using a back and forth motion, slide the magazine catch stop out as far as possible. Repeat until the magazine catch stop can be removed.

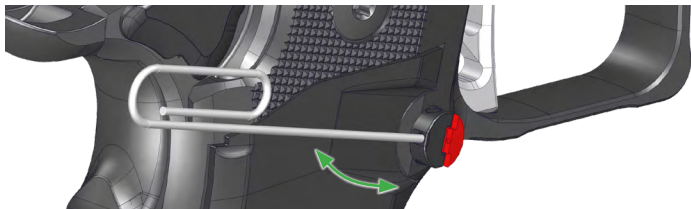

4. Remove the magazine catch, magazine catch spring, and magazine catch stop from the grip.

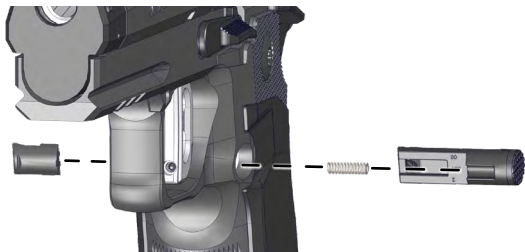

13.1.2 INSTALLATION

1. Insert the magazine catch button and spring into the preferred side of the grip module and completely push the button inward.
2. Insert the magazine catch stop into the magazine catch button until it snaps into place.

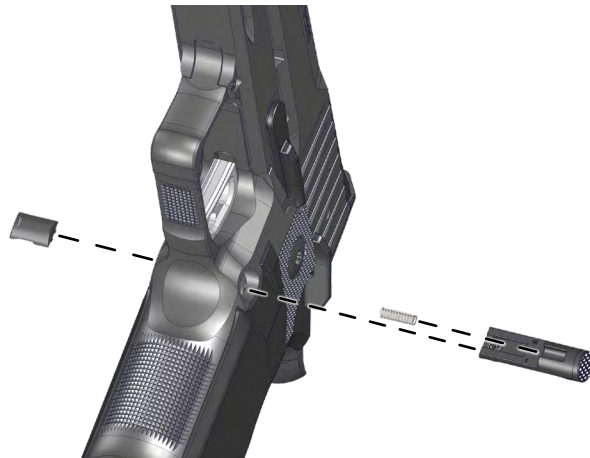



13.2 GRIP PANELS

13.2.1 REMOVAL

CAUTION

DO NOT UNSCREW THE UPPER GRIP SCREWS. FAILURE TO COMPLY CAN DAMAGE THE FIREARM OR RENDER IT NONFUNCTIONAL.

1. Using a T25 drive bit, unscrew the lower grip panel screw and remove it and the grip panel from the firearm.

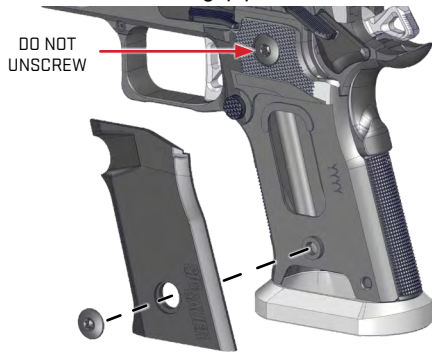

2. Repeat for the grip panel on the other side.

13.2.2 INSTALLATION

1. Install the grip panel to the firearm, ensuring that the hole for the screw threads is aligned.
2. Using a T25 drive bit, install the lower grip panel screw and tighten to 15 in-lbf.



3. Repeat for the grip panel on the other side.



13.3 MAGAZINE FUNNEL

13.3.1 REMOVAL

1. Loosen the magazine funnel screw and remove the magazine well with the screw.

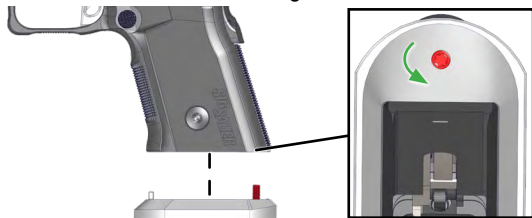

2. Slide the screw to the right, then pull it up to remove.

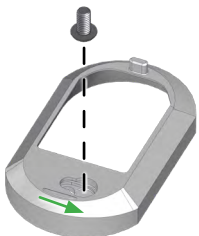

13.3.2 INSTALLATION

1. Place the magazine well screw in the hole in the rear of the magazine well, then slide the screw in to the left.

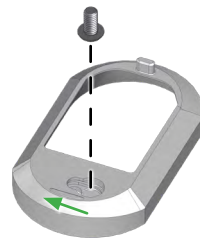

2. Align the well post and screw with the corresponding holes in the grip and tighten the screw to 25 in-lbf. While tightening the screw, take care that the post remains aligned with its hole.

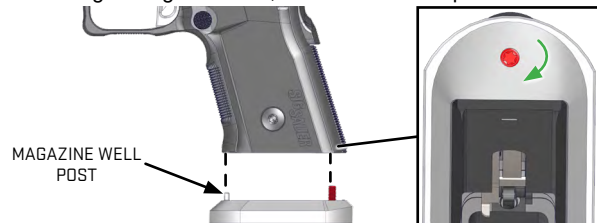



13.4 LOW PROFILE MAGAZINE WELL

13.4.1 REMOVAL

1. Using a T15 drive bit, unscrew and remove the magazine well screw.
2. Remove the low profile magazine well.



13.4.2 INSTALLATION

1. Align the magazine well post with the corresponding hole in the bottom of the grip module, then place the low profile magazine well against the grip module.
2. Using a T15 drive bit, install the magazine well screw through the magazine well and torque to 25 in-lbf.

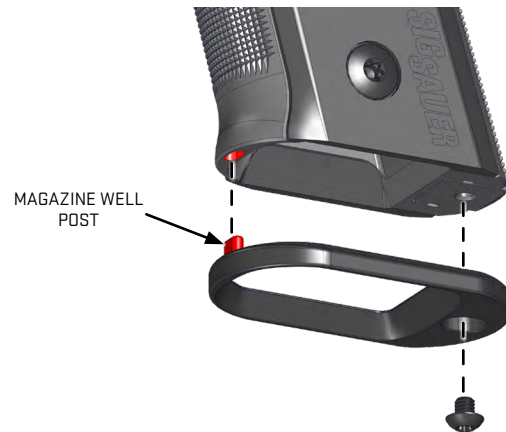



13.5 TRIGGER OVERTRAVEL SCREW

The P211 is features a trigger overtravel screw to allow the operator to adjust the trigger overtravel. This adjustment comes factory preset but may be adjusted if desired.

CAUTION

TURNING THE TRIGGER OVERTRAVEL SCREW TOO FAR CLOCKWISE WILL PREVENT THE PISTOL FROM FIRING. IF THE TRIGGER DOES NOT FUNCTION AFTER ADJUSTING THE OVERTRAVEL, TURN THE SCREW COUNTERCLOCKWISE UNTIL ALL FUNCTION CHECKS PASS, THEN ROTATE IT AN ADDITIONAL TURN COUNTERCLOCKWISE.

For overtravel adjustments, use a 1/16-in. hex tool. Perform a function check after every adjustment. See *12.0 Function Check on page 83*.

- To decrease the overtravel, turn the overtravel screw clockwise.
- To increase the overtravel, turn the overtravel screw counterclockwise.

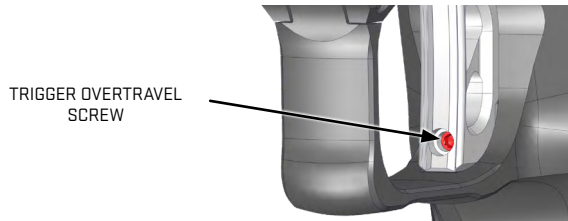

14.0 SIGHTS

The SIG SAUER P211 pistol is equipped with a drift adjustable front sight blade and fixed rear sights.

CAUTION

SIG SAUER SUGGESTS THAT FIXED-SIGHT CORRECTIONS SHOULD BE PERFORMED ONLY BY A CERTIFIED SIG SAUER ARMORER. FAILURE TO COMPLY COULD RESULT IN DAMAGE TO THE SIGHTS OR PISTOL.

The P211 slide is also equipped with an optic filler plate, which can be removed to install an optic. The P211 is compatible with ROMEO1PRO, ROMEO2, ROMEO-X, ROMEO-X PRO, SIGLOC footprints. The P211 may also be compatible with other optics with similarly dimensioned footprints. Contact Customer Service for more compatibility information.

Factory installed ROMEO electro optics sights may or may not have MOTAC™ (Motion Activated Illumination System) capabilities. Always ensure that the optic is powered off when not in use to conserve battery life.

For SIG SAUER ELECTRO-OPTICS installations and adjustments, please see the Operator's Manual for the specific sight. Scan the QR code below to visit the sigsauer.com website and download operator's manuals.





14.1 REAR SIGHT

14.1.1 REMOVAL

1. Using a T8 drive bit, unscrew the rear sight from the top and remove it and the rear sight screw.
2. Remove the rear sight screw from the sight.

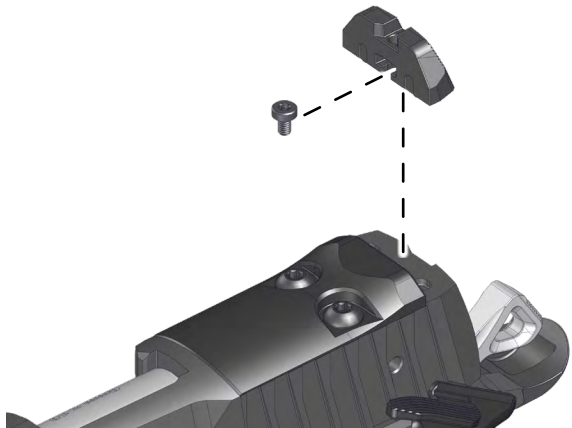

14.1.2 INSTALLATION

1. Install the rear sight screw into the rear sight through the front.
2. Align the posts on the bottom of the rear sight and the rear sight screw with their corresponding holes in the slide and install the rear sight.
3. Using a T8 drive bit, tighten the rear sight screw to 8 in-lbf.

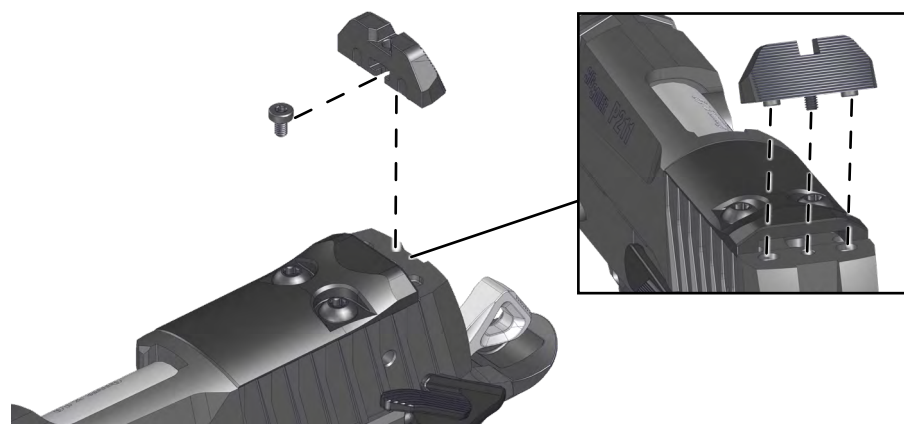



14.2 OPTIC FILLER PLATE

14.2.1 REMOVAL

1. Using a T20 TORX® drive bit, unscrew the two optic filler plate screws.

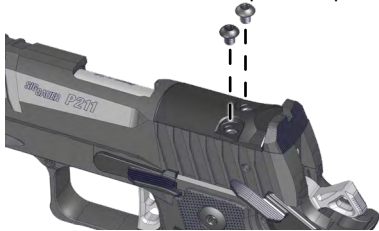

2. Remove the optic filler plate.



14.2.2 INSTALLATION

1. Place the optic filler plate in the cut in the slide.



2. Using a T20 drive bit, install the two optic filler plate screws and tighten to 28 in-lbf.

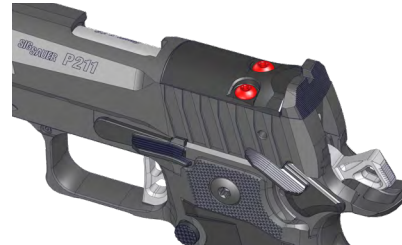



14.3 SIG-LOC ELECTRO-OPTICS

14.3.1 INSTALLATION

1. Field strip the pistol. See *11.1 Field Strip the Pistol on page 49*.
2. Remove the optic filler plate as shown in *7.1 Slide Disassembly on page 62*.
3. Install the wedge at the front of the optic into the slot in the slide (1) at an angle.
4. Pivot the optic down into place, ensuring that the recoil lugs (3) are inserted in their mounting holes (4).

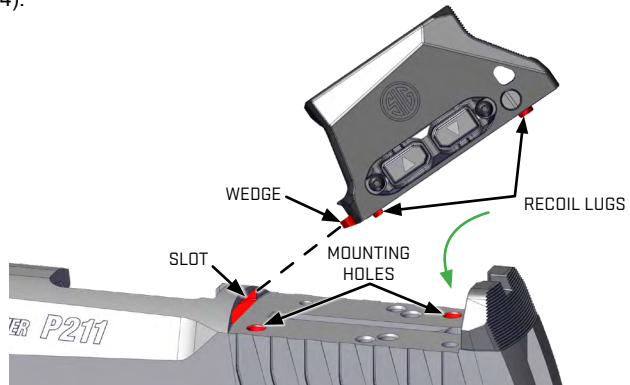

5. Using a T8 drive bit, install the mounting screws from the bottom of the slide and torque to 18 in-lbf.

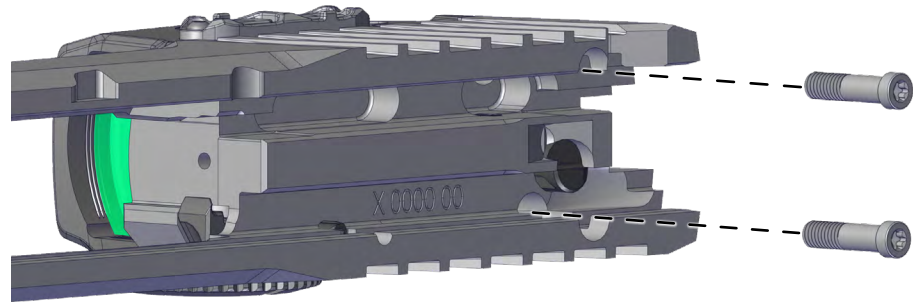



14.3.2 REMOVAL

1. Using a T8 drive bit, remove the mounting screws from the bottom of the slide.
2. Lift the rear of the optic, then remove the optic from the slide.

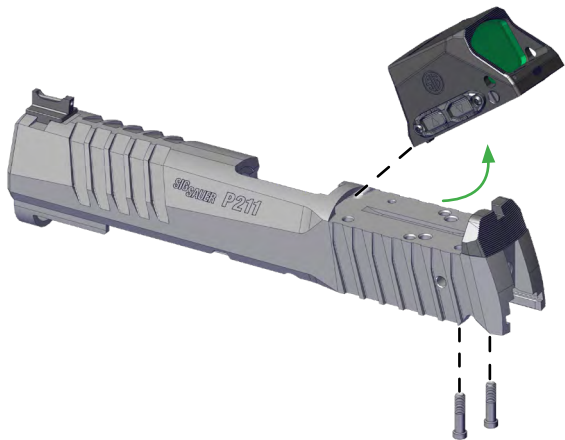

15.0 STORAGE AND TRANSPORTATION

15.1 STORAGE



WARNING STORAGE

NEVER PLACE OR STORE ANY FIREARM IN SUCH A MANNER THAT IT MAY BE DISLODGED. FIREARMS SHOULD ALWAYS BE STORED, LOCKED, UNLOADED, SEPARATE FROM THEIR AMMUNITION, AND INACCESSIBLE TO CHILDREN AND ANY OTHER UNAUTHORIZED PERSON. THE USE OF A LOCKING DEVICE OR SAFETY LOCK IS ONLY ONE ASPECT OF RESPONSIBLE FIREARMS STORAGE. FAILURE TO PROPERLY STORE FIREARMS MAY CAUSE SERIOUS INJURY OR DEATH TO SELF OR OTHERS, OR PROPERTY DAMAGE.

Short Term Storage (90 days or less)

1. Ensure the chamber and magazine do not contain live ammunition.
2. Clean the bore and chamber.
3. Apply a generous coat of CLP to the chamber and bore.
4. Apply a light coat of CLP to all other metal surfaces for corrosion protection.



Long Term Storage (90 days or longer)

1. Ensure the firearm is thoroughly cleaned.
2. Apply a medium coat of CLP to the chamber and bore.
3. Apply a light coat of CLP to all other metal surfaces for corrosion protection.
4. Wrap the firearm with a waterproof material.
5. Place the firearm in a corrosion resistant barrier bag.

Environmental Storage Recommendations (Armory)

Provide humidity control to limit the relative humidity to no greater than 40% at 80°F (26.7°C). If personnel will be working in these areas, design to 68°F (20.0°C) dry bulb and 40% RH for indoor design heating conditions, and 75°F (23.9°C) dry bulb and 40% RH for indoor design cooling conditions.

15.2 TRANSPORTATION

IT IS THE OWNER'S RESPONSIBILITY TO FAMILIARIZE THEMSELVES WITH THE LAWS OF ANY JURISDICTION(S) THEY ARE PLANNING TO TRAVEL TO AND THROUGH WITH THE FIREARM.

When transporting the firearm to and from shooting activities, keep it unloaded for safety purposes. When storing the firearm for transportation, keep it separated from ammunition, under lock and key, and out of the reach of children and other inexperienced or unauthorized persons.

If transporting the firearm in a vehicle, ensure that it is secured within the confines of the vehicle. Should the vehicle become involved in an accident, the firearm could become dislodged and move about the interior of the vehicle or be ejected from the vehicle.

16.0 REPLACEMENT PARTS POLICY



WARNING

IT IS THE PURCHASER'S RESPONSIBILITY TO BE ABSOLUTELY CERTAIN THAT ANY PARTS ORDERED FROM THE FACTORY ARE CORRECTLY FITTED AND INSTALLED. FIREARMS ARE COMPLICATED MECHANISMS AND IMPROPER FITTING OF PARTS MAY RESULT IN A DANGEROUS MALFUNCTION, DAMAGE TO THE FIREARM, AND SERIOUS INJURY TO THE SHOOTER AND OTHER PERSONS. THE PURCHASER AND INSTALLER OF PARTS MUST ACCEPT FULL RESPONSIBILITY FOR THE CORRECT ADJUSTMENT AND FUNCTIONING OF THE FIREARM AFTER SUCH INSTALLATION.

Parts Policy

Our Service Department maintains a full complement of replacement parts. Even though most gunsmiths have the knowledge, training, and the ability to make necessary repairs to the firearm, the skill and workmanship of any particular third-party gunsmith is totally beyond our control.

Should the firearm ever require service, it is strongly recommended that it be returned to SIG SAUER Inc. A firearm is a precision instrument and some replacement parts will require individual fitting to ensure correct operation. A wrong part, improper fitting, or incorrect mechanical adjustment may result in an unsafe condition or dangerous malfunction, damage to the firearm, or cause possible serious injury to the shooter or others.



IF ANY PART IS ORDERED WITHOUT RETURNING THE FIREARM TO SIG SAUER, Inc. the customer bears full responsibility for ensuring that the part supplied is correct for their particular firearm and is properly installed and fitted by a qualified gunsmith.

SIG SAUER INC. IS NOT RESPONSIBLE FOR THE FUNCTIONING OF ANY FIREARM IN WHICH REPLACEMENT PARTS ARE INSTALLED BY OTHERS.

THE USE OF UNAUTHORIZED AFTERMARKET PARTS WILL VOID THE WARRANTY OF THIS FIREARM. THE REPLACEMENT OF ORIGINAL EQUIPMENT MANUFACTURER (OEM) SIG SAUER PARTS WITH AFTERMARKET PARTS IS UNAUTHORIZED AND IN SOME INSTANCES COULD ALTER THE FUNCTION OF THE FIREARM, CREATING A DANGER TO THE OPERATOR.

Scan the QR code below to visit the Small Parts Shopper page at sigsauer.com.



17.0 TROUBLESHOOTING GUIDE

17.1 STOPPAGES



WARNING STOPPAGE



STOP FIRING IMMEDIATELY. UNLOAD AND CLEAR THE FIREARM.

A stoppage is an interruption in the pistol's cycle of function that can be cleared by the operator taking immediate action. Immediate action consists of steps taken by the operator to place the pistol back in service without investigating the cause of the stoppage.

Immediate action:

1. Keep the firearm pointed in a safe direction.
2. Unload and clear the firearm immediately by removing the magazine, locking the slide to the rear, and clearing any ammunition from the firearm.
3. Visually and physically checking the chamber, breech face, and magazine well.

With the firearm unloaded and cleared, perform an additional visual inspection of the firearm and the ammunition. If a bore obstruction exists, refer to *17.2 Obstructed Bore on page 108*. If damage to the firearm is found, the stoppage persists, or a malfunction is suspected, take the firearm to a certified SIG SAUER Armorer for service.



17.2 OBSTRUCTED BORE



WARNING OBSTRUCTED BORE



STOP FIRING IMMEDIATELY AND KEEP THE FIREARM POINTED IN A SAFE DIRECTION. UNLOAD AND CLEAR THE FIREARM. DO NOT FIRE ANOTHER ROUND UNTIL THE OBSTRUCTION IS CLEARED. FAILURE TO COMPLY CAN RESULT IN SERIOUS INJURY OR DEATH TO THE OPERATOR AND/OR OTHERS AND CATASTROPHIC DAMAGE TO THE FIREARM.

Immediately stop shooting and keep the firearm pointed in a safe direction whenever:

- There is difficulty or unusual resistance in chambering a cartridge;
- A cartridge misfires (does not go off);
- The mechanism fails to extract a fired cartridge case;
- Unburned grains of propellant powder are discovered spilled in the mechanism;
- A shot sounds weak or abnormal.

It is possible that a bullet is lodged part way down the barrel. If a bullet is in the bore, do not attempt to shoot it out by using another cartridge or by blowing it out with a blank or a cartridge from which the bullet has been removed. Firing a subsequent bullet into the obstructed barrel can damage the firearm and cause serious injury to the shooter or bystanders. Bullets can become lodged in the barrel when the cartridge has been improperly loaded without propellant powder, the powder fails to ignite, or the bullet was not properly seated in the cartridge case.

If it is suspected that a bullet is obstructing the barrel, immediately unload and clear the firearm. Field strip the firearm and look through the bore of the barrel. It is not sufficient to merely look in the chamber; a bullet may be lodged some distance down the barrel where it cannot easily be seen. Attempt to remove the bullet by tapping it out with a cleaning rod. If the bullet can be removed, clean any unburned powder grains from the bore, chamber, and mechanism before resuming shooting. If the bullet cannot be dislodged by tapping it with a cleaning rod, take the firearm to a certified SIG SAUER Armorer.

17.3 COOK-OFF



WARNING COOK-OFF



COOK-OFF IS DEFINED AS A CHAMBERED CARTRIDGE DETONATING DUE TO THE HEAT OF THE BARREL. FAILURE TO COMPLY WITH THE BELOW LISTED STEPS COULD RESULT IN DEATH, SERIOUS INJURY, OR PROPERTY DAMAGE.

If the pistol stops firing with a cartridge in the chamber of a hot barrel due to a misfire or stoppage, remain calm and do the following:

1. Keep the pistol pointed in a safe direction.
2. Immediately remove the magazine and chambered cartridge.
3. If the cartridge cannot be removed within 10 seconds, keep pistol pointed in a safe direction and wait at least 15 minutes for the chamber and barrel to cool, then remove the cartridge.

**17.4 GENERAL STOPPAGES**

Stoppage	Cause	Correction
Failure to Feed		
No round fed into chamber	Magazine is not properly inserted or is damaged	Insert magazine properly or change magazine
Slide does not close easily or completely	Pistol or cartridge is fouled (dirty) or pistol is incorrectly lubricated	Clean and properly lubricate pistol and / or replace the ammunition
	Incorrect ammunition	Replace ammunition
	Pistol requires service / evaluation	Contact Customer Service
Failure to Extract or Eject		
After firing, the case stays in the chamber or is jammed in the ejection port	Insufficient recoil due to dirt	Clean and lubricate the pistol
	Low-powered ammunition	Change ammunition
	Pistol requires service / evaluation	Contact Customer Service
Failure to Fire		
Trigger is fully pulled but round does not fire	Faulty ammunition	Replace ammunition
	Hammer obstructed	Inspect, clean, and lubricate the pistol
	Trigger overtravel overadjusted	Adjust correctly (See 13.5 <i>Trigger Overtravel Screw on page 94</i>)
	Pistol requires service / evaluation	Contact Customer Service

17.5 MINIMIZING STOPPAGES

- Most stoppages can be minimized by cleaning and lubricating the pistol. See 11.2 *Cleaning and lubricating the P211 Pistol on page 56*.
- Cleaning and lubricating the pistol after each range session will reduce the chances of a stoppage due to dirt and residue buildup.
- Perform maintenance if the firearm is exposed to extreme environmental conditions (rain, snow, freezing temperatures, etc.).
- Periodically inspect the pistol if it is to be stored for extended periods of time without use.
- Most stoppages are directly related to the magazine. Perform maintenance on the magazines as well as the firearm. See 11.5 *Magazine Maintenance on page 75*.
- Mark the magazines so that magazines related to a stoppage can be easily identified.



18.0 FACTORY REPAIR OF THE FIREARM

Contact Customer Service for questions or concerns regarding the performance or serviceability of the firearm. There are three ways to contact Customer Service:

Have the firearm's serial number available before contacting Customer Service.

1. Call (603) 610-3000, choose option 1.
2. Email CustomerService@sigsauer.com.
3. Go to <https://www.sigsauer.com/customer-support> to message Customer Service electronically. Scan the QR code below to visit the Customer Support page at [sigsauer.com](https://www.sigsauer.com).

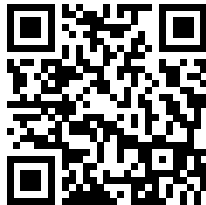

18.1 RETURNING FIREARMS FOR REPAIR

Do not ship a firearm without an RMA number provided by Customer Service.



WARNING DO NOT SHIP AMMUNITION



BEFORE SHIPPING ANY FIREARM, BE ABSOLUTELY CERTAIN THAT THE FIREARM AND MAGAZINES ARE UNLOADED. DO NOT SHIP AMMUNITION WITH A FIREARM.

1. The RMA number allows SIG SAUER to track the status of the return from the time SIG SAUER receives the firearm until it is returned.
2. Package the firearm securely to prevent damage.
3. Do not include any accessories such as scopes or mounts unless directed to do so.
4. Some states and localities require firearms to be shipped and returned to SIG SAUER using a federally licensed firearms dealer.
5. Federal law prohibits persons who do not possess a Federal Firearms License (FFL) from shipping a firearm via the U.S. Postal Service.
6. Any shipment of firearms outside U.S. borders is subject to the export laws of the United States and to the valid laws of the specific country.
7. SIG SAUER is not responsible for any damage to a firearm during shipping until it is received.
8. Firearms must be insured and prepaid prior to shipment (SIG SAUER does not accept collect shipments) to the address provided by Customer Service.



19.0 PARTS DIAGRAMS

19.1 STANDARD SLIDE PARTS

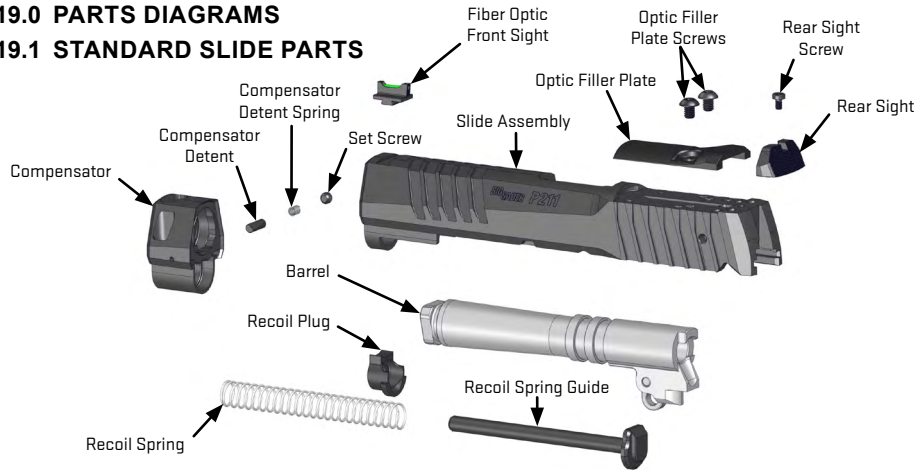

Recoil Spring Color	Spring Tension Weight
Green	8 lb.
Yellow	10 lb.

19.2 STANDARD FRAME PARTS

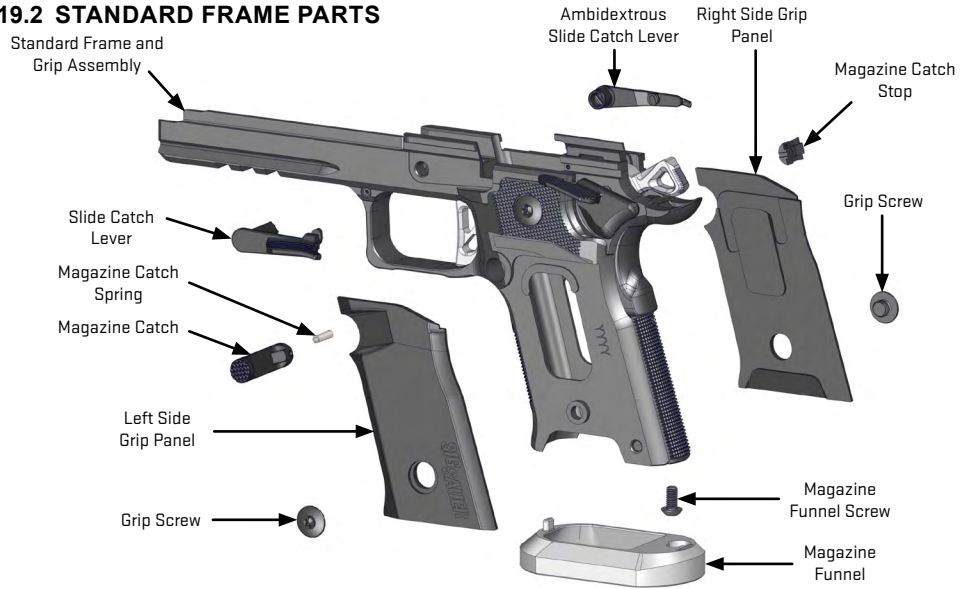



19.3 GT5 SLIDE PARTS

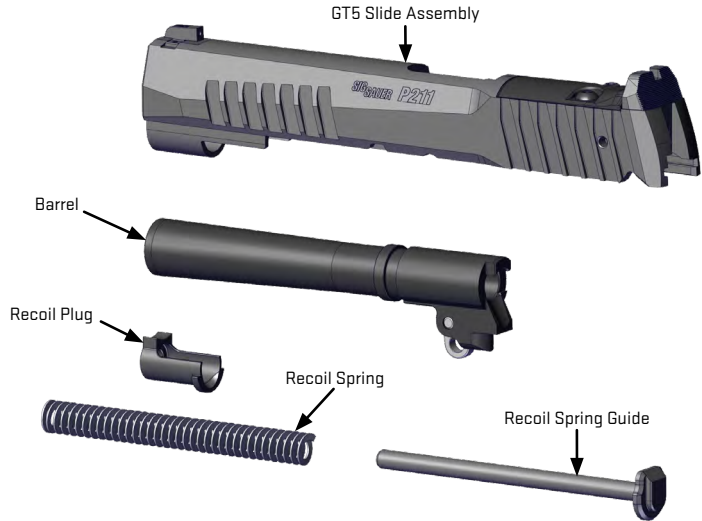

19.3.1 GT4 SLIDE PARTS

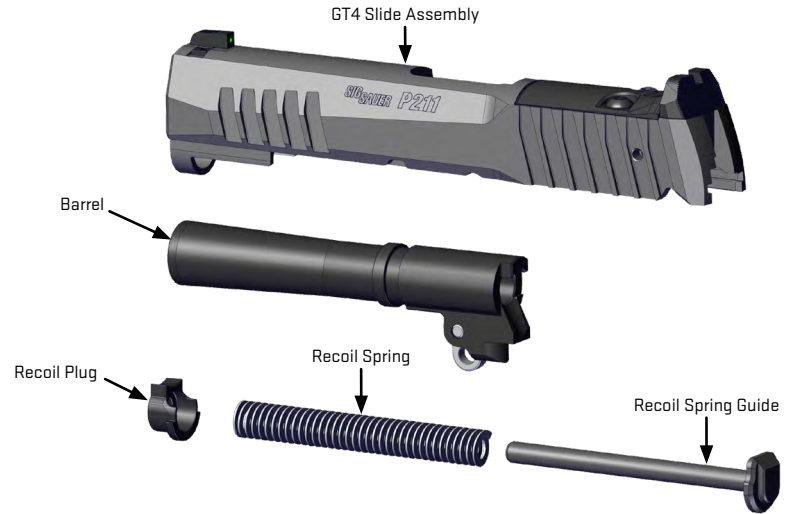



19.3.2 GT4 FRAME PARTS

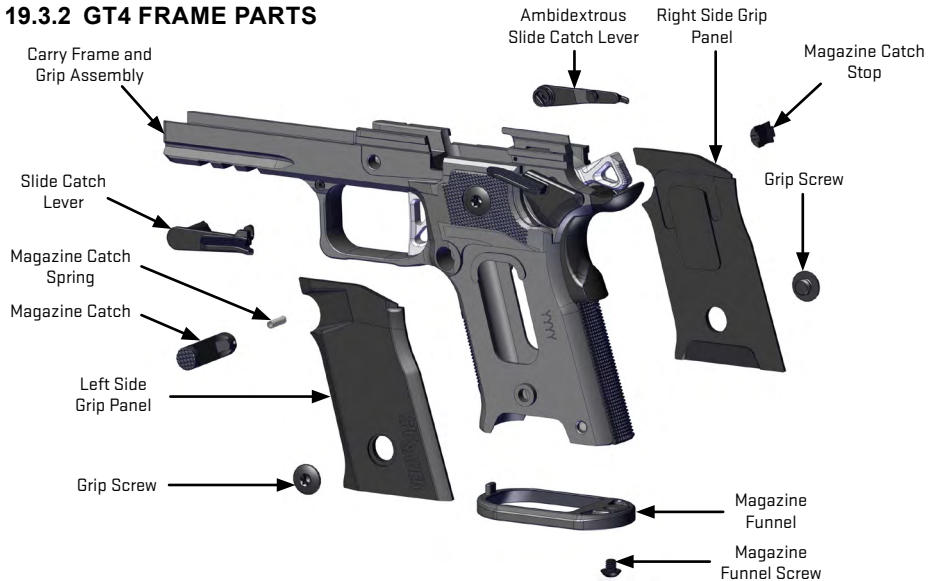

SIG SAUER INFINITE GUARANTEE™

For warranty information on new SIG SAUER firearms, scan the QR code below to visit the SIG SAUER Warranty Information and Registration page. New firearms can also be registered and warranty information can be found on the website.

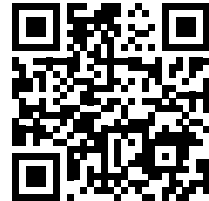

SIG SAUER®

sigsauer.com

**SIG SAUER, Inc.
72 Pease Boulevard, Newington, NH 03801 USA**

All trademarks, service marks, trade names, trade dress, product names, and logos appearing in this manual are the property of their respective owners. No trademark or service mark appearing in this manual may be used without written consent of the mark's owner.