

SIGSAUER[®] **SILENCERS**



OWNERS MANUAL: HANDLING & SAFETY INSTRUCTIONS



PLEASE REMEMBER THAT A SOUND-SUPPRESSED FIREARM IS STILL A FIREARM, AND AS SUCH, ALL SAFE HANDLING REQUIREMENTS AND PROCEDURES APPLICABLE TO FIREARMS APPLY.

SIG Silencers utilize advanced design, state-of-the-art manufacturing processes, and superior materials to take their place as the new standard in professional grade suppression. They were designed from the ground up to provide optimal suppression with no loss in host firearm reliability, accuracy, or durability. While designed and manufactured for greater performance, the life expectancy of your SIG Silencer is directly proportionate to the firing schedule of the host weapon, and its regular care and maintenance.

TABLE OF CONTENTS

1.0 Safety and Handling	3
2.0 Rimfire Silencers (Rifle and Handgun)	9
3.0 Centerfire Handgun Silencers	10
4.0 Direct Mount Rifle Silencers	16
5.0 QD Silencers	18
6.0 Maintenance	28
SIG SAUER® Limited Lifetime Warranty	33

WARNING

Read this owner's manual and the manual for any host firearm before using this product. Failure to do so can result in serious injury or death.

1.0 Safety and Handling

1.1 The Basic Rules of Safe Firearms Handling

1. ALWAYS treat every gun as if it were loaded.
2. ALWAYS be sure the barrel is clear of any obstruction.
3. ALWAYS be sure of your backstop, what lies beyond, and the safety of bystanders before you shoot.
4. ALWAYS use clean, dry, original factory-made ammunition of the proper type and caliber for your gun.
5. ALWAYS use ear protection and safety glasses when shooting.
6. ALWAYS carry your gun so that you can control the direction of the muzzle if you fall or stumble.
7. NEVER shoot at a flat surface or water.
8. DO NOT leave an unattended gun loaded. Guns and ammunition should be stored separately, locked if possible, beyond the reach of children, careless adults, and unauthorized users.
9. NEVER allow your firearm or silencer to be used by anyone who has not read and understood this owner's manual and the owner's manual applicable to your firearm.
10. DO NOT point any gun, loaded or unloaded, at any undesired target.
11. NEVER fire your rifle near an animal unless it is trained to accept the noise: an animal's startled reaction could injure it or cause an accident.
12. NEVER drink alcoholic beverages or take drugs before or during shooting, as your vision and judgment could be seriously impaired, making your gun handling unsafe.

1.2 Attaching/Handling SIG Silencers (Direct Thread)

WARNING

Before attaching silencer to firearm, remove the magazine from your firearm, make sure the bolt or slide is locked to the rear and firearm is unloaded by performing a physical and visual inspection.

1) Screw the silencer onto the barrel threads of your weapon and hand tighten. See specific torque/tightening instructions below. Special care should be taken to prevent cross-threading.

TORQUE SPECIFICATIONS		
Category	Model	
Centerfire Handgun	9mm / 45ACP	10 ft/lbs max
Rimfire	.22LR	Hand tighten
Centerfire Rifle	5.56/7.62 NATO w/ standard barrel	25-30 Ft/lbs

⚠ WARNING

It is the responsibility of the user to match the thread of the silencer with the thread of the barrel.

⚠ WARNING

Periodically check that the silencer remains securely threaded to the barrel, as threaded silencers can unscrew during firing. It is the responsibility of the user to ensure the silencer remains securely threaded onto the barrel of the host firearm.

⚠ WARNING

Make sure you are wearing heat-resistant gloves while re-tightening or removing a silencer from the host weapon after firing. Silencer can reach extremely high temperatures during and after firing.

1.3 Firing

WARNING

Your Sig Silencer is designed to reduce the sound pressure of the cartridge it is designed for to below 140dB, which is the OSHA standard for "Hearing Safe" sound pressures for Impulse or Impact noise. Noise exposure of a more sustained duration beyond "Impulse or Impact levels" will be lower than 140dB and the use of additional hearing protection may be required to maintain a "Hearing Safe" level.

WARNING

DO NOT fire non-jacketed frangible or pre-fragmented ammunition through any SIG Silencer. Fragments may damage the silencer device, cause a safety hazard, and void the product warranty.

WARNING

DO NOT fire "Tracer" ammunition that contains phosphorous pellets for illumination. Faulty projectiles could cause damage to your silencer.

Make sure the bullet weight and twist-rate of your firearm matches the specifications below:

Common Barrel Twist-Bullet Weights		
Model	Twist	Max Weight
9mm / 45ACP	1:10	147 gr
.22LR	1:16	50 gr
5.56 NATO	1:9	60 gr
5.56 NATO	1:7	77 gr
7.62 NATO	1:10	175 gr

It is the responsibility of the user to know the recommended twist rate from the ammunition manufacturer and verify that the host firearm's barrel is so equipped.

1.4 Removing Silencers from Host Weapon

WARNING

Before removing any silencer from its host firearm, remove the magazine from your firearm, make sure the bolt or slide is locked to the rear and the firearm is unloaded by performing a physical and visual inspection.

1) Using heat-resistant gloves, remove the silencer by unscrewing it from the host weapon barrel threads. Care should be taken during and after firing in the handling of your silencer. The silencer can easily reach temperatures that would cause thermal injuries to human skin if there is direct exposure. Only attempt to remove your silencer when the temperature of the silencer has cooled enough to touch. Heat resistant gloves may help, but caution should be taken not to exceed the working temperature of the glove material.

Care should be taken with regard resting hot silencers against items that are flammable or items that have a low melting temperature, like plastics and nylon bags

2.0 Rimfire Silencers (Rifle and Handgun)

2.1 Specifications - .22 Long Rifle

Model	SRD22
Caliber	.22 Long Rifle
Length	6.2"/157.4mm
Diameter	1.25"/ 31.75mm
Weight	7.7 oz/218.2 grams
Mount	½-28 TPI and M9x.75 (both included)
Material	Aluminum & Stainless Steel
Sound Reduction	117dB

2.2 Features

- Hard coat anodized aluminum tube
- Stainless steel mount and baffles for durability
- Fully user serviceable
- 17-4 baffles
- 17-7 Stainless baffle liner

2.3 Tightening/Torque Specification

SRD22 silencers should only be hand tightened to the barrel of the host firearm.

3.0 Centerfire Handgun Silencers

WARNING

Avoid petroleum-based liquids as they may cause smoking and fire, thus causing safety and performance issues.

Ammunition Recommendation

For optimal performance it is recommended that you use quality, factory loaded SubSonic ammunition that travels below 1050ft/sec (SubSonic) in your firearm

3.1 Specifications

Model	SRD9	SRD45
Caliber	9mm Luger	.45 ACP
Length	7.2" / 182.88mm	7.9" / 200.66mm
Diameter	1.38" / 35.05mm	1.38" / 35.05mm
Weight	9.0 oz / 255.146 g	12.0 oz / 340.194 g
Mount	½-28 TPI & M13.5x1 LH Pistons	.578-28 TPI & M16x1 LH
Material	Grade9 Titanium & 17-4 PH Stainless Steel	Grade9 Titanium & 17-4 PH Stainless Steel
Sound Reduction	128dB (Dry)	133 dB (Dry)

3.2 Features

- Lightweight Grade9 Titanium tube
- 17-4 PH Stainless steel baffles
- PVD finish
- Fully user serviceable
- SRD9 includes standard ½-28 TPI & metric M13.5x1 LH Pistons
- SRD45 includes .578-28 TPI & metric M16x1 LH pistons
- .40 S&W conversion pistons available for SRD45 in 9/16-24 and metric M14.5x1 LH

3.3 Tightening/Torque Specification

SRD9 and SRD45 Silencers should be tightened to, and not exceed 10 ft/lbs.

3.4 Disassembly

- 1) Unscrew the rear cap from the rear of the silencer. The piston and spring can be extracted from the assembly by pushing the exposed rear of the piston forward from the piston bore.
- 2) Remove the front end cap of the silencer with the provided tool
- 3) Orient the front of the silencer down and the nine baffles will slide from the tube.

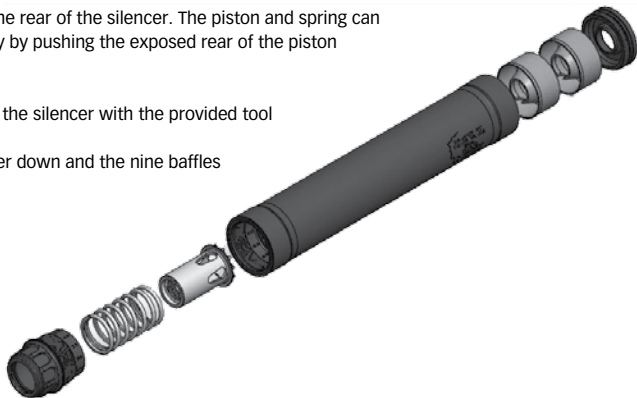

3.5 Cleaning and Maintenance Centerfire Handgun Only

⚠ WARNING

DO NOT use sandpaper or emery cloth to clean any part of the Silencer.

- 1) Using a piece of solvent moistened Scotch-Brite™, clean carbon deposits from the interior and exterior of the rear cap, exterior of the piston.
- 2) Using a nylon brush or similar implement, clean carbon from the spring with solvent.
- 3) Using solvent and a nylon brush, clean carbon deposits from the interior surfaces of the rear cap interface in the rear of the silencer body.
- 4) Check and if necessary replace the high temperature Viton -018 O-ring in the rear cap. O-ring may be purchased from website store.
- 5) Using a nylon brush and solvent remove any carbon deposits from the baffles. The centerfire handgun baffles are made from 17-4 stainless and can be used with any solvent safe for stainless steel and are safe for Ultrasonic cleaners.

3.6 Reassembly

1) Insert the nine baffles into the silencer tube, with concave sides of baffles facing away from the rear of the silencer.



Note there is no specific order or rotational orientation to the baffles, just correct directorial orientation.

Place the spring around the piston shaft.

2) Reattach the front end cap using the provided tool. Use care not to cross thread.

3) Apply a small amount of grease to the o-ring in the rear of the rear cap. Reapply as needed to keep the o-ring lubricated. Place the action spring over the body of the Piston and insert the assembly into the rear cap.

4) Thread the rear cap onto the interface at the rear of the silencer.

5) Reassembly is complete.

3.7 Adjustable Point of Impact

The design of the centerfire handgun silencer enables users to make small adjustments to the bullets point of impact by varying the rotational orientation of the silencer in 15 degree increments with respect to the barrel of the host firearm.

- 1) Remove the magazine from the host weapon, retract the slide or bolt and lock it to the rear. Visually and physically inspect the chamber to ensure it is empty and the host weapon is unloaded. Engage the manual safety (if applicable).
- 2) Thread the Silencer to the barrel of the host firearm.
- 3) Care should be taken when handling hot silencers. While holding the host firearm in one hand, pull the silencer body away from the host firearm approximately 1/4 inch, and rotate it in increments of 15 degrees counterclockwise for right hand threads, clockwise for left hand threads.
- 4) Release the silencer body, which will snap back into place and be rotationally secured by the piston alignment tabs in the interface.

⚠ WARNING

When using a handgun silencer on a fixed barrel host, the action spring must be replaced with an accessory fixed barrel spacer.

4.0 Direct Mount Rifle Silencers

4.1 Specifications - .223/5.56 NATO Silencers

Model	SRD556	SRD556Ti
Caliber	5.56 NATO	5.56 NATO
Length	6.4"/162.5mm	6.4"/162.5mm
Diameter	1.625 "/41.2mm	1.75"/44.5mm
Weight	11.5oz/5.75kg	9.8oz/326 grams
Mount	½ x 28 TPI Taper Thread	½ x 28 TPI Taper Thread
Material	Stainless Steel and Inconel718 Alloy	Grade5 Titanium
Sound Reduction	133dB	134dB

4.2 Specifications - .308/7.62 NATO/.300 WIN MAG/300 Blackout Silencers

Model	SRD762	SRD762Ti
Caliber	7.62/300 WIN MAG/300 BLK OUT	7.62/300 WIN MAG/300 BLK OUT
Length	6.6 "/167.6mm	9.3"/236mm
Diameter	1.625"/41.2mm	1.75"/44.4mm
Weight	15.5oz/439.4 grams	17.6 oz/499 grams
Mount	5/8-24 TPI Taper-Lok™	5/8-24 TPI Taper-Lok™
Material	Stainless Steel and Inconel718 Alloy	Grade5 Titanium
Sound Reduction	139dB (125 dB 300 BLK)	135 dB (122 dB 300 BLK)



4.3 Torque Specifications

SIG Silencers direct mounted silencers should be tightened to, and not exceed 25-30 ft/lbs. On SIG Silencers direct thread silencers, wrench flats are provided to torque or loosen the silencer on both the front and rear of the silencer

5.0 QD Silencers

5.1 Attachment

SIG Silencers use a unique 3-piece mounting system that is specifically designed to work on SIG SAUER tapered rifle barrels and is compatible with standard barrel profiles as well. This system provides the most secure, reliable, and repeatable method of mounting SIG Silencers to the firearm. The Taper-Lok™ system is a self-centering design which provides the most accuracy and prevents any loosening during shooting.

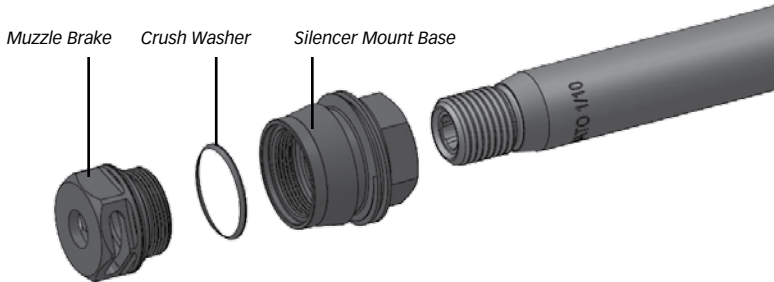

Installation of SIG SAUER® Silencers muzzle devices

Provided:

Muzzle Brake Base
Crush Washer
Muzzle Brake/Flash Hider
Rocksett™

Recommended:

Torque Wrench – ft. /lb.
Crow's Foot wrench
5.56mm – 3/4"
7.62mm – 7/8"
Geissle Reaction Rod or AR Upper Vi
Solvent (acetone, paint thinner)

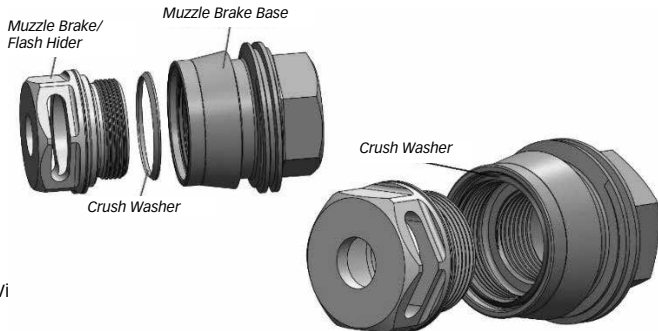

Instructions for installation of SIG SAUER® Silencers muzzle devices

1. With appropriate wrench and upper fixture, remove any muzzle devices from your rifle, including any washers, shims or jam nuts.

⚠ WARNING: Follow solvent instructions for use and precautions*

2. Clean and degrease the barrel threads with solvent.

3. Degrease the threads inside the Sig Muzzle Brake Base with solvent. Allow solvent to evaporate before installing.

4. Apply 2 to 3 drops of the provided Rocksett adhesive.

- Do not use any washers, shims or jam nuts in the installation of the Sig Muzzle Brake Base.

5. Wind the Muzzle Brake Base on and off twice, quickly, to spread the adhesive. There is no timing required for the Muzzle Brake Base.

6. Torque the Muzzle Brake base in place using 20-30ft/lb. Clean off any excess Rocksett™.

7. Allow the Rocksett™ to cure for 24hrs before using.

Timing muzzle brake

1. Insert the supplied crush washer as illustrated, large side of the bevel in the Muzzle Brake Base.
2. Wind the Muzzle Brake or Flash Hider in until compression starts.
3. You have approximately a full rotation and a half of compression to time the Muzzle Brake.
 - The Muzzle device Crush Washers are a one time use item and should be replaced if the Muzzle Brake/Flash Hider is removed.

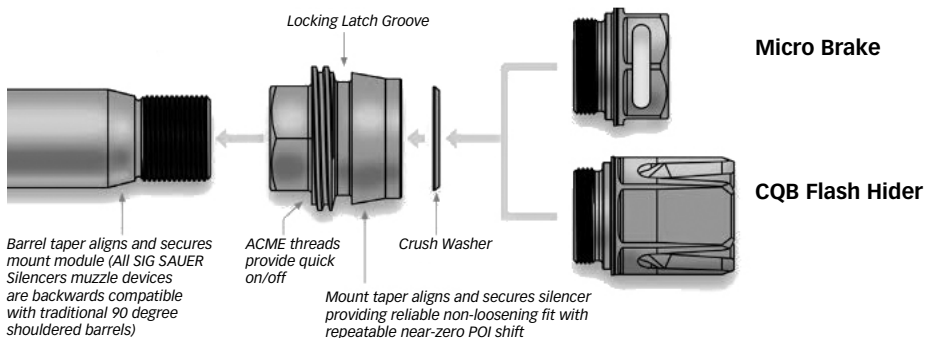

5.2 Specifications – .223/5.56 NATO Silencers

Model	SRD556-QD	SRD556Ti-QD
Caliber	5.56 NATO	5.56 NATO
Length	6.5"/165.1mm	6.81"/173mm
Diameter	1.625 "/41.2mm	1.75"/44.5mm
Weight	14oz/396 grams	11.8oz/334.5 grams
Mount	½ x 28 TPI Taper Thread	½ x 28 TPI Taper Thread
Material	Stainless Steel and Inconel718 Alloy	Grade5 Titanium
Sound Reduction	134dB	135dB



5.3 Specifications - .308-7.62 NATO/.300 WIN MAG/ 300 BLACK OUT

Model	SRD762-QD	SRD762Ti-QD
Caliber	7.62/300 WIN MAG/300 BLK OUT	7.62/300 WIN MAG/300 BLK OUT
Length	7.0"/177.8mm	8.3"/210.8mm
Diameter	1.625"/ 41.275mm	1.75"/44.4mm
Weight	17.0 oz/482 grams	15.8 oz/448 grams
Mount	5/8-24 TPI Taper-Lok™	5/8-24 TPI Taper-Lok™
Material	Stainless Steel and Inconel718 Alloy	Grade5 Titanium
Sound Reduction	140dB (122 dB 300 BLK)	137 dB (125 dB 300 BLK)

SRD762-QD and SRD762Ti-QD are also available with Taper-Lok™ fast Attach bases threaded 1/2 -28 TPI, 3/4-24 TPI, 25/32-24 TPI, M15x1, M18x1, or M18x1.5



5.4 Specifications – 338 Lapua Magnum

Model	SRD338Ti-QD
Caliber	338 Lapua Magnum
Length	10.5" / 266.7mm
Diameter	1.75" / 44.45mm
Weight	18.9 oz / 535.80g
Mount	5/8-24 TPI Taper-Lok™
Material	Grade5 Titanium
Sound Reduction	138dB

SRD338Ti-QD is also available with Taper-Lok™ Fast-Attach bases threaded 1/2 -28 TPI, 3/4-24 TPI, 25/32-24 TPI, M15x1, M18x1, or M18x1.5



5.5 Installing the SIG QD Silencer to the Muzzle Brake Assembly

1. Ensure all threads and bearing surfaces are clean and undamaged (Do not lubricate threads).
2. Start threading the silencer (clockwise) to the muzzle brake mount by hand until the silencer stops on the taper.
3. Turn the silencer an additional 1/8 turn until snug.

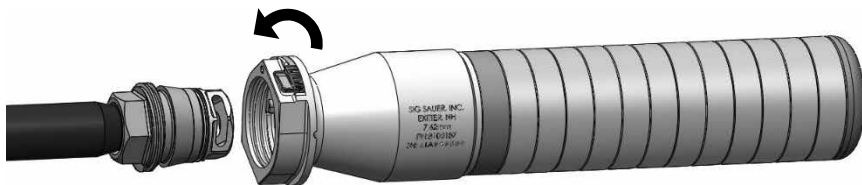

5.6 Removing the SIG-SD Silencer

SIG SAUER recommends removal of the silencer every 200-300 rounds, to ensure the build-up of carbon does not seize the silencer to the barrel threads or muzzle device.

1. Rotate the silencer counterclockwise just enough to break the friction seal with the mount.
2. Then depress the latch and continue rotating the silencer counterclockwise until the silencer is completely free from the mount. Note: that it will take approximately 20% more rotational force to break the friction loose than it was to install the silencer.

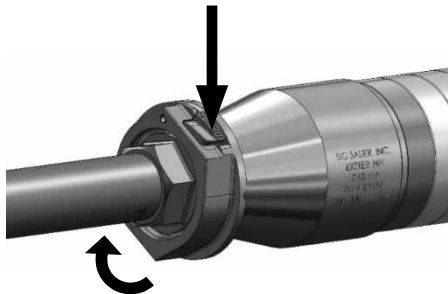

5.7 Removing the SIG Silencer if stuck after extended shooting.

1. Brace the firearm.
2. Place the SIG Silencer wrench or a 1.5" wrench across the latch engaging the flats of the suppressor flange (this will depress and unlock the retention latch).

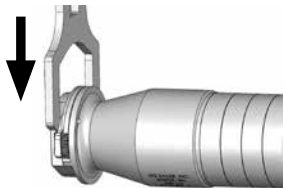

3. Rotate the wrench counterclockwise.



6.0 Maintenance

Rimfire Silencers

The SRD22 silencer disassembles for maintenance, and comes with two different rear adapter plates (1/2"x28tpi and M9x.75) allowing the silencer to be used with a variety of firearms.

Includes:

- Tool
- Inner Sleeve
- Front End Cap
- Tube
- Seven 17-4 baffles
- Two rear adapter plates.
One threaded 1/2"x28tpi and one M9x.75mm



Centerfire Direct Thread Rifle Silencers

If the intent is to share the silencer amongst multiple host firearms, it is recommended to remove the silencer after every 200 rounds fired. This interval of removal / re-installation breaks any carbon fouling on the threads. If cleaning is desired, use of a copper solvent or an ultrasonic cleaner is recommended.

6.1 Disassembly & Cleaning

⚠ WARNING

Before attaching or removing any silencer from its host firearm, remove the magazine from your firearm, make sure the bolt or slide is locked to the rear and firearm is unloaded by performing a physical and visual inspection.

- 1) Unscrew the silencer from the barrel of your weapon. The provided tool can assist with removal.



2) Use included tool to remove the front and rear caps.



3) Push on Inner Sleeve to remove it along with the 7 baffles.
Push the baffles and inner sleeve from the exterior tube.

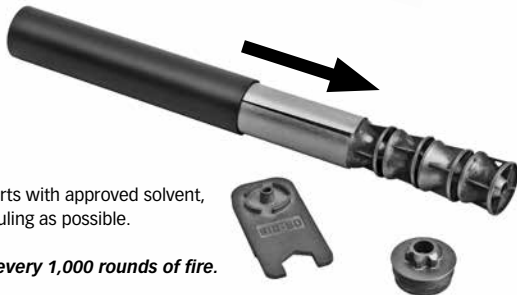

4) Thoroughly wipe and clean all parts with approved solvent,
making sure to remove as much fouling as possible.

Cleaning is recommended after every 1,000 rounds of fire.

5.2 Reassembly

1) Install the front end cap.



2) Insert the 7 baffles into the sleeve, ensuring the concave side of each baffle is facing in the same direction.

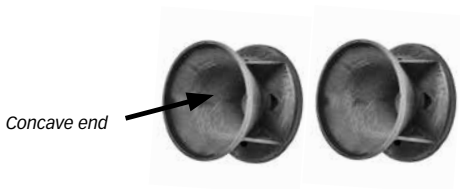

3) Insert the sleeve with baffles into the silencer tube, with concave sides of baffles facing away from the rear of the silencer.

Note: There is no specific order or rotational orientation to the baffles, just correct directorial orientation.



4) Attach the rear end plate using the included tool.
Screw on the cap until it is tightly sealed against the baffle stack.



SIG SAUER® Limited Lifetime Warranty

SIG SAUER® warrants that the enclosed silencer device was originally manufactured free of defects in material, workmanship and mechanical function. For the lifetime of the original purchaser, SIG SAUER agrees to correct any defect in the silencer for the original purchaser by repair, adjustment or replacement, at SIG SAUER's option, with the same or comparable quality components (or by replacing the silencers at SIG SAUER's option); provided, however, that the silencer is returned freight prepaid to:

**SIG SAUER
18 Industrial Drive
Exeter, NH 03833**

This limited warranty is null and void if the silencer device has been misused, damaged (by accident or otherwise), fired with handloaded, reloaded or improper ammunition, fired with an obstruction in the barrel, damaged through failure to provide reasonable and necessary maintenance as described in the manual accompanying the silencer device, or if unauthorized repair or any alteration, including of a cosmetic nature, has been performed on the silencer device. This limited warranty does not apply to normal wear and tear of any parts. Subject to the foregoing, this limited warranty confers the right to have the covered silencer device or its parts repaired, adjusted or replaced exclusively upon the original purchaser, which right is not transferable to any other person. No implied warranties of any kind are made herein and this warranty does not apply to any accessory items attached or appurtenant to the silencer device. In no event shall SIG SAUER be liable for any incidental or consequential damages arising from or in connection with this limited warranty.

Notes:

Notes:

SIGSAUER[®]
when it counts[®]

www.sigsilencers.com

**FOR PRODUCT SERVICE ON THIS MODEL,
PLEASE CALL (603) 610-3000 EXT. 1**

72 Pease Boulevard, Newington, NH 03801 USA